

C-NCAP Management Regulation

(2018 edition)

China Automotive Technology and Research Center

Table of Contents

Foreword.....	3
Chapter I General Provisions.....	5
1 Objectives.....	5
2 Management body.....	6
3 C-NCAP test items.....	6
3.1 Occupant protection.....	6
3.2 Pedestrian protection.....	7
3.3 Active safety.....	8
3.4 Additional test – fuel consumption measurement.....	8
4 Assessment results.....	8
5 Designated website and media.....	8
6 C-NCAP’s exclusive label.....	9
Chapter II Operation Management.....	10
1 Selection of vehicle types for assessment.....	10
2 Vehicle and spare parts acquisition.....	11
3 Tests.....	11
4 Release of assessment results.....	12
5 Funds.....	13
6 Management of third-party personnel and related affairs during test.....	14
7 Complaints over the results and their solution.....	15
8 Processing of test data, graphical information, and post-test vehicles.....	15
9 Use of C-NCAP assessment results and related signs.....	15
10 Technological communication.....	15
11 Communication and Public propaganda activities.....	15
Chapter III Assessment Procedures.....	16
1 Occupant protection.....	16
1.1 Test items.....	16
1.2 Performance parameters and scoring method.....	18
2 Pedestrian protection.....	39
2.1 Test items.....	39
2.2 Performance index and scoring method.....	40
3 Active safety.....	44
3.1 Test items.....	44
3.2 Performance index and scoring method.....	46
4 Scoring and star rating.....	52
Chapter IV Impact Test and Whiplash Test Procedures.....	55
1 Procedures for frontal impact test against rigid barrier with 100% overlapping.....	55
2 Frontal impact test against deformable barrier with 40% overlapping.....	78
3 Side impact test procedure.....	103
4 Whiplash test procedures.....	120
Chapter V Test Method of Pedestrian Protection.....	130
1 Vehicle preparation.....	130

2	Vehicle marking	131
3	Headform test	144
4	Legform test	151
5	Test of vehicles with active deployable bonnet system	161
Chapter VI Test of Autonomous Emergency Braking System (AEB) of Vehicle		168
1	Terms and definitions	168
2	Test of autonomous emergency braking system (AEB CCR) in rear collision of vehicle	169
3	Pedestrian autonomous emergency braking system (AEB VRU_Ped) test.....	179
Chapter VII Additional Test -- Fuel Consumption Measurement Procedures		186
1	Inspections of vehicle	186
2	Test preparations	186
3	Test	189
4	Vehicle parameters to be verified for the additional test	190
Appendix 1 Feedback Sheet for Vehicles Undergoing C-NCAP Assessment		192
Appendix 2 C-NCAP Test Performing Notice		194
Appendix 3-1 C-NCAP Basic Parameters of the Test Vehicle 1 - (Part of Crash and Whiplash Tests).....		195
Appendix 3-2 C-NCAP Basic Parameters of the Test Vehicle 2 -(Part of Pedestrian Protection).....		197
Appendix 3-3 C-NCAP Basic Parameters of the Test Vehicle 3 -(Part of AEB)		201
Appendix 4 Sheet of Complaint on C-NCAP Assessment.....		205
Appendix 5 Application Form Undergoing C-NCAP Assessment.....		206
Appendix 6 Specimen of Releasing of C-NCAP Assessment Results		207
Appendix 7 C-NCAP Work Flow Diagram		208
Appendix 8 ESC Parameter Comparison Table.....		209
Appendix 9 Information Sheet of Manufacturer's Sample (for Gasoline Vehicle).....		210
Appendix 10 C-NCAP Recording Sheet of Measurements and Scoring for Impact Tests.....		212

Foreword

Starting from 1979 when USA adopted NCAP system - New Car Assessment Programme, the safety of vehicle is gradually accepted by consumers. Various countries/districts have launched NCAP evaluation for more than 30years. In 2006, in order to promote the rapid development of China's automobile product safety technology level, to reduce the rate of casualties in road traffic accidents and to achieve the goal of building a harmonious automobile society, on the basis of research and reference of other counties' experiences on NCAP, CATARC established its own C-NCAP (China New Car Assessment Program) in 2006, taking consideration of Chinese automotive standard, technology and economic development.

In NCAP system, test method is as same as the one used in regulation approval test, but with more and stricter test items. Taking example, qualification test in NCAP includes head injury, thorax compression and thigh axial force, as well as neck and leg damages parameters. Meanwhile, for making up the shortage of bio-mechanics, NCAP also tests the deformation of body, occupant compartment and steering system, to evaluate the possible causes of occupants' injury. Most importantly, NCAP has a set of mature safety assessment methods, converting the determination of "pass" and "fail" for the regular test into the perceivable and qualified star rating assessment. Due to the wide influence, strict standard, normative tests, justice, direct result release to customers and reflection on the actual safety situation the vehicle, NCAP attaches attention of all main auto manufacturers, who take it as key evaluation reference for vehicle R&D. manufacturers who obtain good rating in NCAP test, take the test result as the promotion way for market launch.

Experiences prove that NCAP does improve auto safety and road traffic safety. For ten years of C-NCAP implementation, the safety technology of local vehicles and assessment scoring are increasingly upgraded, fitment ratios of safety devices significantly increase, large numbers of Chinese consumers use safer car products and access safer driving experience, it has a significant effect to improve China's road traffic safety situation. C-NCAP has become China's automobile product safety research and development of the vane; it has become synonymous with car safety. Following the further research and implementation of C-NCAP, CATARC has optimized and enhanced "C-NCAP Management Regulation" for several times, and C-NCAP has experienced changes of 2006 edition, 2009 edition, 2012 edition and 2015 edition. Nowadays, passive safety technology is becoming more and more sophisticated, and active safety technology has also enter a rapid leap-style development stage. The integration of passive and active safety technologies will constitute an all-round vehicle occupant protection system. Therefore, C-NCAP is on the basis of three original tests such as frontal impact test against rigid barrier with 100% overlapping, frontal impact test against a deformable barrier with 40% overlapping and side impact test against a mobile deformable barrier and whiplash test, is once again improved. In response to the high incidence of pedestrian accidents in China, the pedestrian protection test and the autonomous emergency braking (AEB) test are added in the right time. Scoring and star rating system also made a larger adjustment. Since then, the new "C-NCAP management rules (2018 version)" is introduced by the three major sections, which are the occupant protection, pedestrian protection and active safety.

The main changes of C-NCAP Management Rules (2018 Edition) compared to 2015 Edition are as follows:

- Added the pedestrian protection test and evaluation;
- Added the autonomous emergency braking (AEB) test and evaluation;
- Modified parameters of the movable deformable barrier in side impact test;
- Modified score weights of rear dummies in the crash test.
- Increased the velocity of whiplash test;
- Modified score weights of different parts of dummy in whiplash test.
- Added technical requirements on the bonus points of curtain airbags;
- Added bonus points and requirements for the rear seat belt warning device;
- Added the pure electric vehicle / hybrid electric vehicle test procedures and evaluation methods;

- Constructs the new scoring system;
- Modified the vehicle classification;
- Changed other detail descriptions.

“C-NCAP Management Regulation (2018 edition)” is implemented on July 1st of 2018.

Due to the different edition of management regulation, there are the discrepancy of test method and items, so the final evaluation results are not comparable. Therefore, all parties taking advantage of the C-NCAP assessment results shall clarify the edition and date of the test and results, to avoid any negative impact caused by wrong quotation of C-NCAP results.

CATARC reserve all the rights of C-NCAP.

The future, the car will continuously move from "zero death" to "zero casualties", and then to reach the ultimate goal of "zero accident". With the continuous development of vehicle safety technology, car safety will eventually enter a new realm. C-NCAP will continue to lead the Chinese automotive safety technology to achieve new goals. We would like to thank all relevant governmental and industry organizations, domestic and foreign enterprises and professional organizations, and news media for their supports and cooperation in the development of C-NCAP. We hope to get the long-term support and help from all of you in future.

CATARC
20 April 2017

Chapter I General Provisions

1 Objectives

1.1 Purposes

1.1.1 C-NCAP aims at establishing high standard, fair and impartial methods for assessing vehicle safety performance under impact, so as to promote the development of vehicle technologies in pursuit of a higher concept for safety. The intention of the program is to provide consumers with safety information concerning the newly marketed vehicles, encourage the manufacturers to attach higher importance to safety standards, improve the safety performance and technical standards of the vehicles while giving publicity by means of the assessment process to the vehicles that excel in occupant protection.

1.1.2 Likewise, C-NCAP focuses on the procedures for measuring fuel consumption which is immediately related with the interests of the end-users, so as to motivate the improvement of automotive fuel economy and encourage manufacturers to make persistent efforts in upgrading the energy-saving techniques.

1.1.3 These assessment procedures are to be progressively enhanced based on the local evolutions of automotive technologies as well as the deep-going researches on the road traffic situations.

1.2 Notes

- (1) No stylized test procedure can fully reflect the protection provided by a vehicle in the wide variety of accidents which occur on the roads. The methods provided by C-NCAP for assessing and rating the vehicles' safety performance in qualitative and quantitative terms can reflect the vehicle's safety performance to certain extent only.
- (2) No anthropometrical dummies are available which can measure all potential risks of injury to humans or assess protection for different sizes of occupant in different seating positions.
- (3) Economic constraints prevent the tests from being repeated, so to take account of vehicle and test variations a number of actions have been taken:
 - a) The manufacturers of the vehicles are required to compare the results of the C-NCAP tests with those of their own tests that may have been conducted, and to report any anomalies that they have found together with the enterprises' own test results for comparison. Such data will not be taken as a basis for rating the vehicles and will be kept confidential.
 - b) The overall assessments are based on the combination of multiple results. Variations in any one of these will only have a limited effect on the overall rating.
- (4) The requirements of the national standards were set to provide the lowest level of protection only. For car occupants, these limits are too lenient to adequately identify the best practice in current car production and to provide a goal for further improvement. Therefore, by referencing to the NCAP data available overseas, more demanding limits have been set to identify aspects of a car's performance which offer significantly greater protection.
- (5) The additional test of C-NCAP -- measurement of fuel consumption - will be carried out as per the driving cycles (comprising urban and suburban ones) nailed down in the existing appropriate national standard.

1.3 With the launching of C-NCAP and the in-depth investigation of road traffic accidents, we reserve our rights to make modifications to test items, test and scoring methods and assessment clauses, so that the C-NCAP assessment could present the true picture of

China's traffic accidents to the fullest possible degree, provide as much as possible information to the end-users, and make contributions in reducing personal injury, improving vehicle safety performance, and promoting higher fuel economy.

2 Management body

China Automotive Technology and Research Center (CATARC) is the management body of C-NCAP. A C-NCAP Management Center will be specially established to be in charge of the organizing and implementation affairs, including determining the annual plan and financial budget, selecting the vehicle model (including voluntary applications by enterprises) to be assessed, reviewing the assessment results, handling disputes and confusions and determining on other incidental issues. Under the C-NCAP Management Center there will be General Affairs Department, Test Assessment Department and Information and Media Department, which are responsible for the following respectively:

- (1) General Affairs Department: Determining annual implementation plan and financial budget; analyzing and determining vehicle models to be assessed; vehicle procurement; organizing release of information and results; communications and interactions with vehicle manufacturers; contacting consultant committees; conducting international cooperation activities; business promotion and follow-up development of C-NCAP.
- (2) Test Assessment Department: Arranging test schedules; supervising the testing; making assessments according to test results; test management and data evaluation.
- (3) Information and Media Department: Analyzing annual sales information of vehicle models; announcing C-NCAP assessment results; collecting relevant technical information at home and abroad; managing the C-NCAP website and dedicated magazine columns; contacting media partners.

In addition, a C-NCAP Consultant Committee will be established, which will be mainly responsible for putting forward suggestions and opinions concerning the protocols and operations of C-NCAP. The members of the Consultant Committee (including the Guest Monitors) will consist of: experts and scholars with relevant knowledge from institutions of higher learning, research institutes and academic organizations, governmental authorities and agencies, professional organization, consumer organizations and media representatives, etc.

3 C-NCAP test items

This version of the C-NCAP evaluation test is divided into three parts:

- 1) Occupant protection, including impact tests, the low-speed rear-impact neck protection test ("whiplash test").
- 2) Pedestrian protection, including pedestrian protection tests.
- 3) Active safety, including the autonomous emergency braking (AEB) test, the report audit of electronic stability control system (ESC) test.

Fuel consumption test is the C-NCAP additional evaluation part.

3.1 Occupant protection

3.1.1 Impact tests

3.1.1.1 Frontal impact test against rigid barrier with 100% overlapping

The test shall be conducted such that the test vehicle frontally crashes against a fixed rigid barrier with 100% overlapping at an impact speed of 50⁰ km/h (test speed not

lower than 50km/h). The test vehicle approaches the barrier in a route that does not deviate sideways from the theoretical trail by 150mm in either transverse direction. Place a Hybrid III 50 percentile male dummy in the driver's seat and occupant seat respectively in the front row, to measure the injuries to the front seat occupants. Place a Hybrid III 5 percentile female dummy on the most outboard seat to the left of the second row, so as to measure the injuries suffered by the second-row occupants; place a child restraint system and a Q-series dummy representing a 3-years-old child on the most outboard seat to the right of the same row, so as to assess the occupant restraining performance and the protection provided in favor of the child occupants. (See the impact test procedures specified in Chapter IV for details).

3.1.1.2 Frontal impact test against deformable barrier with 40% overlapping

The test shall be conducted such that the vehicle frontally crashes against a fixed deformable endoergic barrier at an impact speed of 64^{+1} km/h. The impact overlapping width between the offset impact vehicle and the deformable barrier shall be within the range of 40% of the vehicle width ± 20 mm. Place a Hybrid III 50 percentile male dummy in the driver's seat and occupant seat in the front row to measure the injury to the occupants in the front seats. Place a Hybrid III 5 percentile female dummy on the left-most seat of the second row, so as to measure the injuries suffered by the second-row occupants (See the impact test procedures specified in Chapter IV for details).

3.1.1.3 Side impact test against mobile deformable barrier

The new trolley fitted with a deformable barrier face to impact with the driver's side of the test vehicle. The mobile barrier is to move in a direction perpendicular to the test vehicle, with the center line of the barrier aligned with the position 250mm rearwards from the R point of the test vehicle, and the impact speed shall be 50^{+1} km/h (test speed not lower than 50km/h). The longitudinal perpendicular plane of the mobile barrier shall be within ± 25 mm from the transverse vertical plane that passes the position 250mm rearwards from the R point of the front row seat on the test vehicle's impact side. Position a WorldSID 50th dummy on the driver's seat to measure the injury to the driver's position. Place a SID-IIs (version D) dummy on the impact side of the second row, so as to measure the injuries suffered by the second-row occupants. (See the impact test procedures specified in Chapter IV for details).

3.1.2 Neck protection test in low-speed rear impact (hereinafter "whiplash test")

By simulating the original vehicle structure, install the driver's seat of test vehicle (together with the restraint system) onto the movable sled. The sled is launched by the special acceleration waveform having the speed variation at (20.0 ± 1.0) km/h, so as to simulate the rear impact process. Place a BioRID II dummy on the seat; through measuring the neck injuries resulted from the rear impact, assess the protection performance of the vehicle seat head restraint in favor of the occupant neck. (For details, see the whiplash test procedures laid down in Chapter 4)

3.2 Pedestrian protection

3.2.1 Pedestrian protection test

The adult head impactor and the child head impactor impact vehicle specific parts respectively at $40^{+0.72}$ km/h speed according to the specified angle in head test. HIC15 values of head tests are scored for each time. And then the TRL upper leg or FLEX leg impactor is selected according to the lower height of the tested vehicle bumper. It impact bumpers at $40^{+0.72}$ km/h speed according to the specified angle in the leg test. The performance values of leg bending moments, knee ligament elongations and others are scored for each time. Head test and leg test results are used to evaluate the effect of vehicle front protection on pedestrian collision. (See the pedestrian protection test method specified in Chapter 5).

3.3 Active safety

3.3.1 Performance test report audit of electronic stability control system (hereinafter referred to as “ESC” system)

ESC system plays a good role to maintain good driving stability. For the testing model equipped with ESC configuration, performance test report should be audited to determine whether the ESC system has the required performance. Vehicle manufacturer should provide the report by qualified third-party testing organizations issued on the model to meet the relevant requirements of the performance test on the vehicle. (See ESC audit report requirements specified in Chapter 3)

3.3.2 Autonomous emergency braking system (hereinafter referred to as “AEB” system) performance test

The AEB system automatically breaks the vehicle to avoid or mitigate collision damages in emergencies. For models equipped with AEB configuration, AEB CCRs tests and AEB VRU_Peds tests should be executed. In AEB CCR and AEB VRU_Ped tests, the testing vehicle run to the static, slow moving and braking simulated vehicle and pedestrian dummy at different speeds. The performance of the AEB system is evaluated by inspection of braking and prewarning situations of the testing vehicle without human intervention. (See the AEB test method specified in Chapter 6)

3.4 Additional test – fuel consumption measurement

Test vehicle shall be preconditioned inside a chamber at temperature of $24^{\circ}\text{C}\pm 3^{\circ}\text{C}$; afterwards, it shall be soaked for 18h~24h. Prior to the test, the engine lube and coolant shall fall within $\pm 2^{\circ}\text{C}$ of the ambient temperature. Carry out the test as per GB/T 19233-2008 and GB 18352.3-2005. (For details, see the fuel consumption measurement procedures set out in Chapter V)

4 Assessment results

C-NCAP evaluates the star ratings based on the overall scores ratios of occupant protection, pedestrian protection and active safety. The score ratios of three parts of occupant protection, pedestrian protection and active safety are calculated respectively according to evaluation tests, and then respectively multiply the weight coefficients of three parts. The sum of each score ratios is the overall score. The star rating is defined by the overall score ratio. In addition to the overall score ratio, the occupant protection, pedestrian protection and active safety of the three parts must also meet the minimum scoring rating requirements (See chapter. IV, Article. 4)

Electric vehicles/ hybrid electric vehicles (EV / HEV), that meet the electrical safety requirements, will be identified by the electrical safety mark  separately, in addition to the published star rating.

Overall score ratio	Star rating
$\geq 90\%$	5+ (★★★★★☆)
$\geq 82\%$ and $< 90\%$	5 (★★★★★)
$\geq 72\%$ and $< 82\%$	4 (★★★★)
$\geq 60\%$ and $< 72\%$	3 (★★★)
$\geq 45\%$ and $< 60\%$	2 (★★)
$< 45\%$	1 (★)

5 Designated website and media

The website www.c-ncap.org and the magazine “World Auto” (monthly) will be C-NCAP Management Center’s designated media for releasing C-NCAP information and test results. The website www.c-ncap.org will focus on introducing the C-NCAP organization, its work procedures, latest developments and comments on test results. It will also have a media service area for other forms of media to download information about test result

comments. The “World Auto” carries information about C-NCAP operations and detailed reports on the assessment results in the form of dedicated columns and special issues, which are not to be quoted without permission.

6 C-NCAP’s exclusive label

C-NCAP has applied and registered the following lettering and label for its exclusive use:



C-NCAP is China’s New Car Assessment Program developed by China Automotive Technology and Research Center (CATARC), which reserves all rights over C-NCAP. No institution is allowed to conduct C-NCAP based tests or assessments on vehicles for publicity or commercial purposes without permission by CATARC, except for the technology development test by enterprises themselves.

The test results, scores and star ratings granted are applicable only to the type of vehicle (same model and configurations) used for the test. Any party applying the C-NCAP assessment results shall be responsible for their trueness, completeness and correctness.

Chapter II Operation Management

1 Selection of vehicle types for assessment

1.1 Principle

1.1.1 The vehicles to be assessed shall be passenger cars (i.e. Category M1 vehicles) newly marketed within the recent two years, and the sales volume of this vehicle model shall exceed 3,000 sets (Except pure electric vehicles / hybrid electric vehicles).

1.1.2 The vehicles to be assessed shall have relatively large sales volume among vehicles of its type, and its production shall not be scheduled to stop in the near future;

or, alternatively, the representative types of local passenger car manufacturers.

1.1.3 Classification of vehicles for selection and result announcement purposes:

- 1) Small passenger vehicles: passenger cars shorter than 4m in length, including small MPVs;
- 2) Class A passenger cars: two-compartment passenger cars with a length no more than 4.5m, or three-compartment passenger cars with a displacement not greater than 1.6L;
- 3) Category B passenger cars: passenger cars longer than 4.5m with a displacement greater than 1.6L (including luxury passenger cars);
- 4) Multi-purpose vehicles: MPV (with more than two rows of seats);
- 5) Sport utility vehicles: SUV (Ground clearance \geq 180mm);
- 6) Pure electric vehicle / hybrid electric vehicle - EV / HEV (with B-level voltage circuit).

1.2 Identifying procedure

1.2.1 The C-NCAP Management Center conducts a statistical analysis on the vehicles newly marketed over the previous two years to preliminarily determine the scope of the candidate vehicle types for the current year's assessment. The candidate vehicle types may be identified in groups according to the annual plan.

1.2.2 The manufacturer will be informed of the candidate vehicle types and will be asked to provide information on the various configurations, the information on stop production, as well as its dealers and etc. (the manufacturer to fill out the Feedback Sheet for Vehicles Undergoing C-NCAP Assessment, see Appendix 1)

1.2.3 Upon receipt of the manufacturer's feedback information, the C-NCAP Management Center will finalize the vehicle types to be assessed, and determine the largest or a relatively large sales volume of configuration according to the sales data of this vehicle type and related configuration.

1.2.4 The vehicle manufacturer may voluntarily apply for the C-NCAP assessment; however, the vehicle type concerned shall be initially placed onto the market within recent two years. For models that have been assessed, vehicle manufacturer may voluntarily apply for the repeating test assessments after half year later after the first evaluation. The selection principle of evaluated vehicle model for voluntary application of assessment is identical with 1.1 of this chapter.

1.3 Procedures and requirements for a manufacturer to apply for the voluntary assessment

1.3.1 Application

To voluntarily apply for subjecting a vehicle type to the C-NCAP assessment, the vehicle

manufacturer shall submit the letter of application for C-NCAP assessment to the C-NCAP Management Center (See Appendix 5).

1.3.2 Examination and approval of the application

After receiving the letter of application for C-NCAP assessment as submitted by the manufacturer, C-NCAP Management Center will conduct reviews against the application qualifications and principles; provided all the requirements are met, the Management Center will accept the application and issue the “Letter of CATARC for Approving Voluntary C-NCAP Assessment” to the manufacturer.

The manufacturer shall, within the specified time limit after receiving the letter mentioned above, deliver all the fees required for the vehicle purchasing and tests.

1.3.3 Miscellaneous

The purchase of vehicles, test procedures, and the announcement of the results are the same as the case in which the assessment is funded by CATARC.

2 Vehicle and spare parts acquisition

2.1 Vehicle models equipped without AEB configuration

For models without AEB configuration, the C-NCAP Management Center, based on the principle of random sampling, purchases all the testing vehicles with a configuration of the largest or a relatively large sales volume and the correspondent seats for Whiplash test, as well as the required hood and front bumper and other parts for pedestrian protection test from the dealer without beforehand informing the relevant manufacturers such purchase. The process of purchase allows the media to participate in, but an advance application is needed.

2.2 Vehicle models equipped with AEB configuration

For models with AEB configuration, if AEB system is included in the configuration of the vehicle with the largest or a relatively large sales volume, the testing vehicles and spare parts purchase procedure is identical to 2.1 of this chapter. If the AEB system has not been equipped on the vehicle with the largest or a relatively large sales volume, the vehicles and spare parts purchase procedures for the crash test, the whiplash test, and the pedestrian protection test shall be the same as those in 2.1 of this chapter. Within 10 working days after receiving the notification from the C-NCAP Management Center, another new vehicle (same model) with AEB system shall be provided by manufacture. The vehicle shall have “Certificate of Conformity for Complete Power-driven Vehicle” and imported vehicle shall have “Goods Import Certificate” issued by customs. After the completion of the AEB test, the vehicle will be returned to the manufacturer after confirmation by both the C-NCAP Management Center and the manufacturer.

3 Tests

3.1 Test performing notice

Having purchased the vehicle and spare parts, a date for the test will be determined through consultation between the General Affairs Department and the Test Assessment Department. 10 to 15 working days prior to the test, a C-NCAP Test Performing Notice (see Appendix 2) will be delivered to the manufacturer stating the vehicle type to be tested, its configuration, test items, and test date, etc.

3.2 Preparation of test

3.2.1 Within 5 workdays after receipt of the Test Performing Notice, the manufacturer shall provide the C-NCAP Management Center with a Table of Basic Parameters of the Test Vehicle (see Appendix 3).

- 3.2.2 All the preparations before the fuel consumption test should be conducted by professional testing staff from the department of testing evaluation. If necessary, the manufacturer's technical staff can confirm the relevant parameters, but shall not carry out any operation on the vehicle.
- 3.2.3 All preparations before the AEB test, including test vehicle preparation, vehicle running-in, test equipment installation, test equipment calibration and so on, shall be conducted by professional testing staff from the department of testing evaluation. The technical staff of the manufacturer can observe the preparation of the test and confirm the necessary parameters within the specified time, but shall not carry out any operation on the vehicles and testing equipment.
- 3.2.4 All the preparations before the pedestrian protection test, including confirmation of the normal driving height, testing area of head and leg tests, grid position of the head impactor, head impactor prediction results, the test sample consistency and the proving material of active hood system shall be conducted by professional testing staff from the department of testing evaluation. The manufacturer shall provide adequate technical support and information, including but not limited to the following information: the head test prediction results, active hood working principle and working status parameters. The technical staff of the manufacturer can observe the preparation of the test and confirm the necessary parameters within the specified time, but shall not carry out any operation on the vehicles and testing equipment.
- 3.2.5 All pre-test preparation including the preparation of the vehicle, adjustment of the occupant compartment, calibration of the dummy, positioning and measuring of the dummy, and preparation of test equipment will be performed by professional test personnel arranged by the Test Assessment Department. Technicians of the manufacturer may, within the specified time limit, view the test preparations, and verify the necessary parameters; provided, however, no manipulation is allowed as to the equipment/apparatus, including vehicle, test dummies, etc.
- 3.2.6 All the preparations necessary for the whiplash test (including preparation of seat fixture, seat adjustment and measurement, dummy certification, dummy placement and measurement, preparation of test equipment, etc.) shall be unfolded by the professional test staff engaged by the Test and Appraisal Dept. Manufacturer shall furnish adequate technical supports, e.g., installation parameters of seat track and others, lead wire for supply coupler of power seat and its definition, special properties such as setting of the memory module, lead wire for the triggering line of seat proactive head restraint and its definition, etc.). Technical professional of manufacturer may, within the prescribed time span, view the test preparations, and verify the necessary parameters; provided, however, no manipulation is allowed to the vehicle, dummy under test or other instrumentation/equipment.

3.3 Testing execution

Tests and data processing shall be carried out by the test professionals according to the operating procedures. Technical personnel of the manufacturer and representatives of the media may view the test process.

3.4 Reviewing the assessment results

C-NCAP Management Center will review and summarize the C-NCAP test results regularly, on which basis the information to be released will be determined.

4 Release of assessment results

4.1 The form of result releasing

The release will be in the form of the star rating finally credited to the vehicle, and the individual scores of all the tests, the score ratio of each section and the overall score ratio are published at the same time. In the case of Section 2.2 of this chapter, the score of the AEB shall be explained. EV / HEV should also publish results of electrical safety

evaluation.

4.1.1 Description of vehicle's configuration

Brand, model, basic parameters, structural characteristics, powertrain, safety configuration of the vehicle under assessment (including: configuration of safety belt and pretensioner, configuration of safety airbag and curtain airbag, as well as the availability of safety belt reminder, ESC system, AEB system and proactive head restraint).

4.1.2 Specimen of releasing the results and supplemental explanations

The specimen of releasing the results and the items therein are shown in Appendix 6; if appropriate, the following supplemental explanations (notexhaustive) may be inserted:

- a) The star rating provided by the test results shall only apply to the vehicle type of the same model and configurations as assessed therein.
- b) Reasons shall be indicated when the star rating and the overall score ratio does not match with each other according to Article 4 of Chapter 3.
- c) In case of a vehicle type assessed based on manufacturer's voluntary application, it shall be such indicated.

4.1.3 Any other measurement data obtained from the assessment tests shall not be published publicly.

4.2 Frequency and method of result releasing

Release frequency: normally once every 3 months. In particular cases, the assessment result would be released at any time.

Releasing method:

- 1) Through C-NCAP designated website (www.c-ncap.org);
- 2) Through dedicated column or special issue of "World Auto", or by media authorized by C-NCAP Management Center;
- 3) By C-NCAP assessment result release conferences, news report and live broadcasting.

Other media are allowed to carry assessment results downloaded from www.c-ncap.org website's media service area, but are required to register and receive authorization before they can make use of such information, and are to indicate the source of such information they release.

"World Auto" will release assessment results and related information in more details in its special issues and dedicated columns, and will allow other media to make in-depth reports by way of copy-right cooperation with World Auto.

5 Funds

5.1 CATARC will set aside annually dedicated budget funds to cover the costs for purchasing the vehicles, conducting the tests and overall management to ensure long-term operation of C-NCAP.

5.2 In the case of C-NCAP tests applied for by vehicle manufacturer, all the required funds (including the costs for purchasing the vehicle intended for the impact tests and for conducting the tests) will be provided by the manufacturer, and the purchasing of vehicles and conducting of the tests will follow the same procedure as the assessments conducted with CATARC funds. The total test cost will be RMB1,180,000. When the manufacturer proposes to increase the test point in the pedestrian protection test, additional test cost shall be provided separately for each additional point and fee charging standard shall be in compliance with the stipulations of relevant fee charging method of test institution.

6 Management of third-party personnel and related affairs during test

6.1 Management of test viewers

- 6.1.1 The each testing schedule of the vehicle to be assessed will be informed to the manufacturer concerned in advance and will be announced on C-NCAP's designated website.
- 6.1.2 The manufacturer shall submit to the C-NCAP Management Center the names of those to view the test three days prior to the date of test.
- 6.1.3 Manufacturer's personnel may view the preparations of impact tests at the specified time spans, and view the test process through the duration beginning half an hour before the test and ending half an hour after the test. Such personnel will be rejected to enter the impact test lab unless with the viewing permit issued to the manufacturer.
- 6.1.4 Media representatives wishing to view the tests shall submit an application and a list of the attendants to the C-NCAP Management Center three days prior to the date of test, and can be present at the testing site only when permission is granted. Media representatives will be rejected to enter the impact test lab unless with the viewing permit issued to the media; in the lab, the shooting time span and zones shall be subject to C-NCAP Management Center.
- 6.1.5 Any other person who wishes to view the impact tests shall submit the application in advance to the C-NCAP Management Center; once approved, he could enter the test lab by presenting the viewing permit.
- 6.1.6 Due to restrictions of test conditions and management, no viewing will be arranged for media and non-manufacturer in the course of AEB test, pedestrian protection test and fuel consumption measurements.

6.2 Management of manufacturer's personnel and test related affairs

- 6.2.1 The manufacturer personnel can confirm the status of the test vehicle before each test. If the problem is found, those personnel should timely communicate with professional testing staff from the department of testing evaluation, and eventually reach an agreement.
- 6.2.2 When manufacturer personnel confirm the test conditions, the content with possibly significant effect on the results shall be confirmed by both professional testing staff from the department of testing evaluation and manufacturer staff. They should be simultaneously recorded in an additional record sheet prepared by the department of testing evaluation.
- 6.2.3 The manufacturer personnel shall not carry out any operation on the vehicles and spare parts during confirmation of the test vehicle status. However, when it is confirmed that there will be some special operation, the relevant operations can be carried out by professional testing staff from the department of testing evaluation after the agreement of the person in charge of the department of testing evaluation.
- 6.2.4 The checking by the manufacturer personnel shall not exceed a limit of 60 minutes, which can be extended for a suitable length when there is a justifiable reason and when the permission is granted by the person in charge of the Test Assessment Department. In such case a summary of opinions can be proposed backed by appropriate reasons, and modifications to the test conditions can be made after permission by the Test Assessment Department is granted.
- 6.2.5 Views from the manufacturer personnel are allowed to take photos or videos before and during the tests only after the permission by the person in charge of the Test Assessment Department is obtained.

7 Complaints over the results and their solution

In the case of dispute over the result of assessment on the part of the manufacturer, a complaint in the form of a Complaint Form (see Appendix 4) can be submitted to the C-NCAP Management Center within 10 days after the announcement of the results. The C-NCAP Management Center shall give a reply within one month after receipt of the Complaint Form. If the dispute still remains, the C-NCAP Management Center may arrange debates on the issue at the request of the manufacturer.

Significant discrepancies in the assessment arising from problems caused by failure in applying the required test procedures during the test are entitled to re-assessment, and such situation will be indicated with the result release. Costs for re-assessment of this type will be borne by the C-NCAP Management Center.

8 Processing of test data, graphical information, and post-test vehicles

All the data and graphical information acquired from the C-NCAP formal assessment tests as well as the post-test vehicles shall be merely furnished to the vehicle manufacturer concerned, by charging certain fees. If interested, the vehicle manufacturer shall so request at C-NCAP Management Center within three months after the release of the results, and deliver the corresponding amount as per the "Handling Procedures for C-NCAP Test Data, Image Data and Post-test Vehicle". In case the assessment is conducted on manufacturer's voluntary application, the vehicle manufacturer may take back the test vehicle after the release of the results.

In case of no request for purchasing or taking back the vehicles three months after the release of the results, it shall be considered that C-NCAP Management Center is authorized to dispose them. The C-NCAP Management Center shall implement the storage and disposal of vehicles in accordance with the internal management documents.

9 Use of C-NCAP assessment results and related signs

The results and related signs as released by C-NCAP may be freely used; provided, however, if they are used for any commercial purpose, the user shall submit a prior statement to C-NCAP Management Center, explaining the sites and formats to use such signs. C-NCAP Management Center shall have right to put forward any requirements in restricting the use.

10 Technological communication

C-NCAP Management Center holds at least one C-NCAP symposium and technical communication activities each year, it could be combined with the evaluation results release activities. OEM and related organizations can carry out various forms of communication and technical cooperation with C-NCAP Management Center.

11 Communication and Public propaganda activities

C-NCAP Management Center may, based on actual demands, attend car shows or organize public propaganda activities including exhibition tours, and conduct various forms of communication to promote safety knowledge and safety consciousness of the public.

Chapter III Assessment Procedures

1 Occupant protection

1.1 Test items

1.1.1 Frontal impact test against a rigid barrier with 100% overlapping

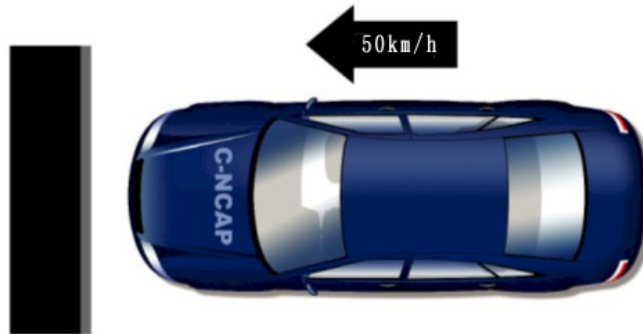

Figure 1 Frontal impact test against a rigid barrier with 100% overlapping

As shown in Figure 1, the test shall be carried out in accordance with the C-NCAP testing procedure. The test vehicle frontally crashes against a fixed rigid barrier with 100% overlapping, which shall be covered by 20mm-thick plywood boards. The impact velocity

is 50km/h (the test speed shall be not less than 50^{+1} km/h). The test vehicle shall not deviate by 150mm from the theoretic track in any transverse direction before crashing against the barrier. A Hybrid III 50 percentile male dummy shall be placed at driver and front occupant positions respectively, to measure the injury to front occupants. Place a Hybrid III 5 percentile female dummy on the most outboard seat to the left of the second row, and place a child restraint system and a Q-series dummy representing a 3-years-old child on the most outboard seat to the right of the same row, so as to measure the injuries suffered by the second-row occupants. In case the ISOFIX anchorages are only fitted to the outboard seat to the left of the second row, the positions of the child dummy and the female dummy may be interchanged. For vehicle model with two-door and single-row seat, only a Hybrid III 50 percentile male dummy shall be placed at driver and front occupant positions respectively, to measure the injury to front occupants.

1.1.2 Frontal impact test against a deformable barrier with 40% overlapping

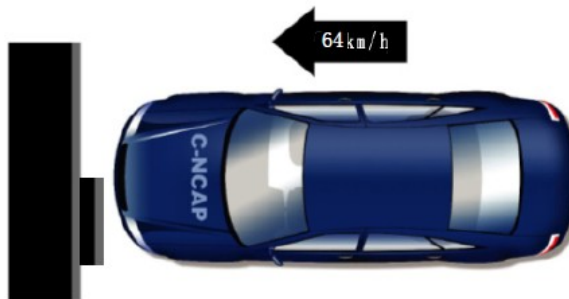

Figure 2 Frontal impact test against a deformable barrier with 40% overlapping

As shown in Figure 2, the test shall be performed in accordance with the C-NCAP testing procedure. The test vehicle frontally crashes against a deformable barrier with 40% overlapping at the impact velocity of 64^{+1} km/h. The overlapping of the vehicle subject to offset impact with the deformable barrier shall be within 40% of vehicle width ± 20 mm. A

Hybrid III 50 percentile male dummy shall be placed at driver and front occupant areas respectively, to measure the injury to front occupants. A Hybrid III 5 percentile female dummy shall be located in the leftmost seat of the second row, so as to measure the injuries suffered by the second-row occupants. For vehicle model with two-door and single-row seat, only a Hybrid III 50 percentile male dummy shall be placed at driver and front occupant areas respectively, to measure the injury to front occupants. During the test, the measurement of the deformation of A-pillar, steering-column and pedals is required.

1.1.3 Side impact test against a mobile deformable barrier

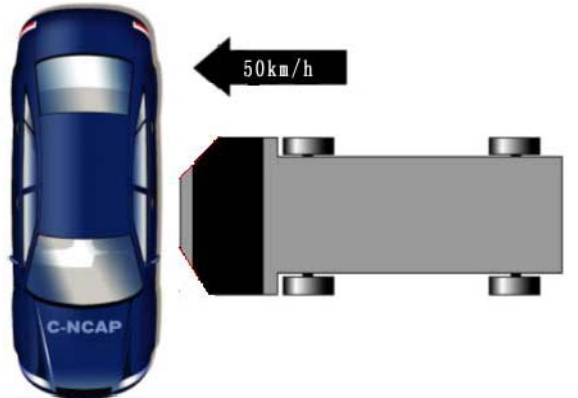

Figure 3 Side impact test against a mobile deformable barrier

As shown in Figure 3, the test shall be performed in accordance with the C-NCAP testing procedure. A deformable cell bond is to be attached to the frontend of trolley. The mobile barrier shall move in the direction perpendicular to the test vehicle. The centerline of the barrier shall align with the 250mm backward of vehicle R-point position. The impact velocity is 50km/h (the test speed shall be not less than 50⁰ km/h). The longitudinal vertical median plane of the mobile deformable barrier shall be coincident within ±25mm with a transverse vertical plane passing through the 250mm backward of R-point of the front seat adjacent to the struck side of the tested vehicle. A WorldSID 50th dummy shall be placed at the driver position; place a SID-II_s (version D) dummy on the impact side of the second row, so as to measure the injuries suffered by the driver the second-row occupants. For vehicle model with two-door and single-row seat, only a WorldSID 50th dummy shall be placed at driver area, to measure the injury to occupants.

1.1.4 Whiplash test

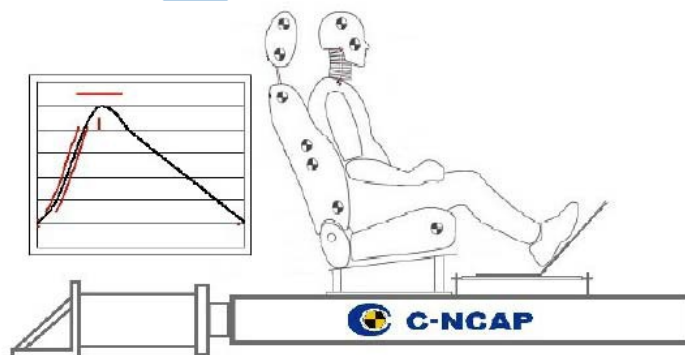

Figure 4 Neck protection test in low-speed rear impact (whiplash test)

As shown in Figure 4, test procedures of C-NCAP are followed. By simulating the original vehicle structure, install the driver seat (together with the restraint system) onto the movable sled. The sled is launched by the special acceleration waveform having the speed variation at (20.0±1.0) km/h so as to simulate the rear impact process. Place a BioRID II dummy on the seat to measure the neck injuries during the rear impact.

1.2 Performance parameters and scoring method

1.2.1 Testing part

1.2.1.1 Frontal impact test against a rigid barrier with 100% overlapping

During the test, a maximum score of 20 points is available. Maximum score for the front-row dummy is 16 points, and the dummy body areas to be scored include head, neck, thorax, upper leg and lower leg, which can be awarded up to 5, 2, 5, 2 and 2 points respectively. The maximum score for the second-row female dummy is 4 points; the body parts of the female dummy are divided into head, neck and thorax, which can be awarded up to 1.6, 0.4 and 2 points respectively.

The scoring for the frontal-row dummies shall be based on the injury criteria of the driver-side dummy. The scores of the occupant-side dummy may be validated only if they are less than the scores for corresponding areas of the driver-side dummy. The basic scoring principle for the adult dummies on the frontal row and the second row is: to set two limits for each parameter, a higher performance limit, threshold for maximum scores, and a lower performance limit, threshold for zero point; if a group involves the scoring of several body parts, the lowest point thereof shall be taken as the final score of the group concerned; the lowest score will be validated for a body region where multiple assessment criteria exist. The scores for each assessment shall be rounded to two decimal places.

1.2.1.1.1 Scoring of frontal-row dummy

1.2.1.1.1.1 Scoring of head position

The maximum and minimum scores for head are 5 points and 0 point respectively.

The score for the occupant-side dummy's head is obtained by measuring relevant parameters of the dummy, while the ultimate score for the driver-side dummy's head is obtained by subtracting the penalty for the deformation of the steering column from the score obtained herewith. The dummy head assessment parameters involve the head injury criterion (HIC36) and the resultant acceleration of 3ms. A maximum score of 5 points is available for each parameter. Higher and lower performance limits are to be used for calculation.

Higher performance limits:	Head injury criterion (HIC36)	650
	Resultant acceleration of 3ms	72g
Lower performance limits:	Head injury criterion (HIC36)	1,000
	Resultant acceleration of 3ms	88g

The lower performance limits and the higher performance limits correspond to 0 point and 5 points respectively. Between the two limits, the score is calculated by linear interpolation and rounded to two decimal places.

With regard to the driver-side dummy, the score for head will be subject to modification with 0~-1, provided that excessive upward displacement of the steering column occurs. The EEVC recommending limit is 80mm. In calculating penalties, up to 90% of the EEVC limits (i.e., 72mm), there is no penalty. Beyond 110% of the EEVC limits (i.e., 88mm), there is a penalty of 1 point. The details are given below:

Upward displacement of steering column	Penalty
≤72mm	0
≥88mm	1

Between the two limits, the score is calculated by linear interpolation and rounded to two decimal places.

1.2.1.1.1.2 Scoring of neck position

The maximum and minimum scores for neck are 2 points and 0 point respectively.

The score for neck is generated by measuring relevant parameters of the dummy. The assessment parameters include shearing force F_x , tension F_z and extension bending moment M_y , which can each be awarded up to 2 points.

Higher performance limits:

Shearing force F_x 1.9kN @ 0msec, 1.2kN @ 25-35msec, 1.1kN @ 45msec

Tension F_z 2.7kN @ 0msec, 2.3kN @ 35msec, 1.1kN @ 60msec

Extension bending moment M_y 42Nm

Lower performance limits:

Shearing force F_x 3.1kN @ 0msec, 1.5kN @ 25-35msec, 1.1kN @ 45msec

Tension F_z 3.3kN @ 0msec, 2.9kN @ 35msec, 1.1kN @ 60msec

Extension bending moment M_y 57Nm

Neck shearing force and tension are assessed from cumulative curve, with the limits being functions of time. By interpolation, a plot of points against time is computed. The score for each point may be calculated by linear interpolation, and the minimum point on this plot gives the score. Plots of the limits and rating boundaries are given in Figure 5, Figure 6 and Figure 7.

For extension bending moment, the score is calculated by linear interpolation and rounded to two decimal places.

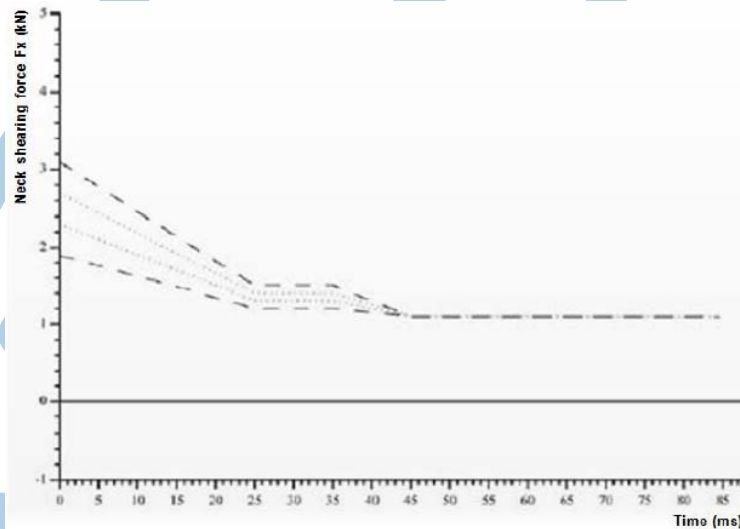

Figure 5 Neck shearing force F_x (positive direction)

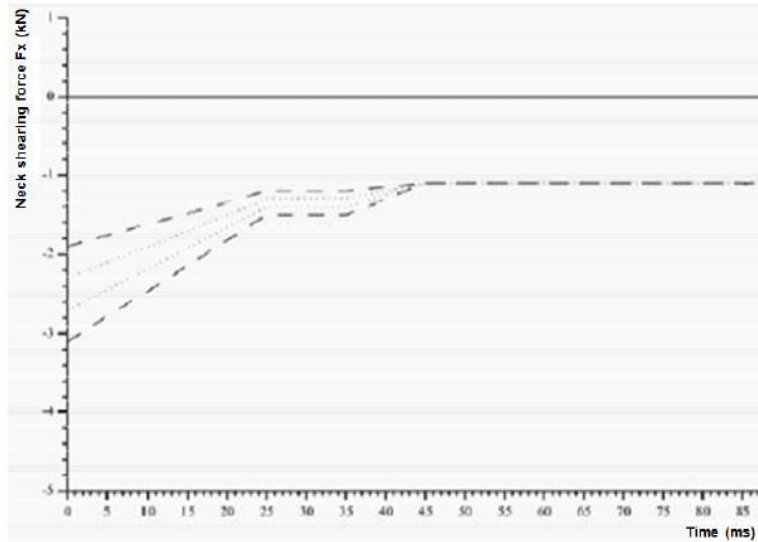

Figure 6 Neck shearing force Fx (negative direction)

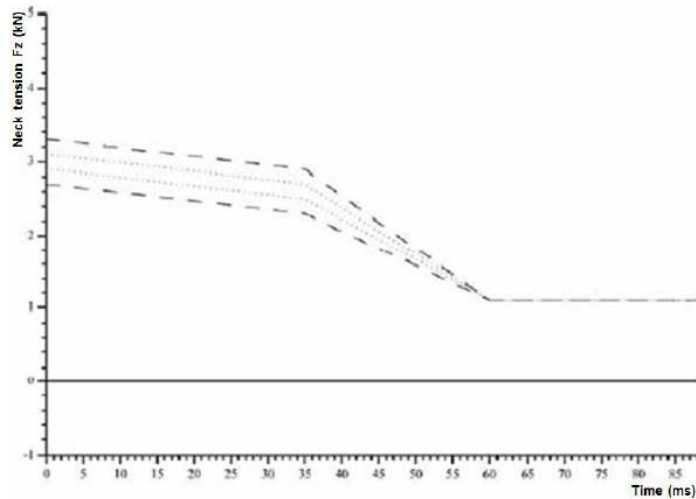

Figure 7 Neck tension Fz (positive direction)

1.2.1.1.1.3 Scoring of thorax position

The maximum and minimum scores for this body area are 5 points and 0 point respectively.

The score for the occupant-side dummy's thorax is generated by measuring relevant parameters of the dummy, while the ultimate score for the driver-side dummy's thorax is obtained by subtracting the penalty for the deformation of the steering column from the score obtained herewith. The dummy chest assessment parameters include the compression and the Viscosity Criterion (VC), a maximum score of 5 points is available for each parameter.

Higher performance limits:	Compressive deformation	22mm
	Viscosity Criterion (VC)	0.5m/s
Lower performance limits:	Compressive deformation	50mm
	Viscosity Criterion (VC)	1.0m/s

The lower performance limits and the higher performance limits correspond to 0 point and 5 points respectively. Where a measurement value falls between the two limits, the score is calculated by linear interpolation and rounded to two decimal places.

With regard to the driver-side dummy, the score for thorax will be subject to modification with 0~-1, provided that excessive rearward displacement of the steering column occurs. The EEVC recommending limit is 100mm. In calculating penalties, up to 90% of the EEVC limits (i.e., 90mm), there is no penalty. Beyond 110% of the EEVC limits (i.e., 110mm), there is a penalty of 1 point.

The details are given below:

Rearward displacement of the steering column	Penalty
≤90mm	0
≥110mm	1

Between the two limits, the score is calculated by linear interpolation and rounded to two decimal places.

1.2.1.1.1.4 Scoring of upper legs position

The maximum and minimum scores for this body area are 2 points and 0 point respectively.

The score for femur is generated by measuring relevant parameters of the dummy. The femur assessment parameters include the femur compression force and the knee sliding displacement. A maximum score of 2 points is available for each parameter.

Higher performance limits: Femur compression force 3.8kN
Knee sliding displacement 6mm

Lower performance limits:

Femur compression force 9.07kN @ 0msec, 7.56kN @ ≥10msec

Knee sliding displacement 15mm

Femur compression force is assessed from a cumulative plot, with the limits being functions of time. By interpolation, a plot of points against time is computed. The score for each point may be calculated by linear interpolation, and the minimum point on this plot gives the score. Plots of the limits and score rating boundaries are given in Figure 8.

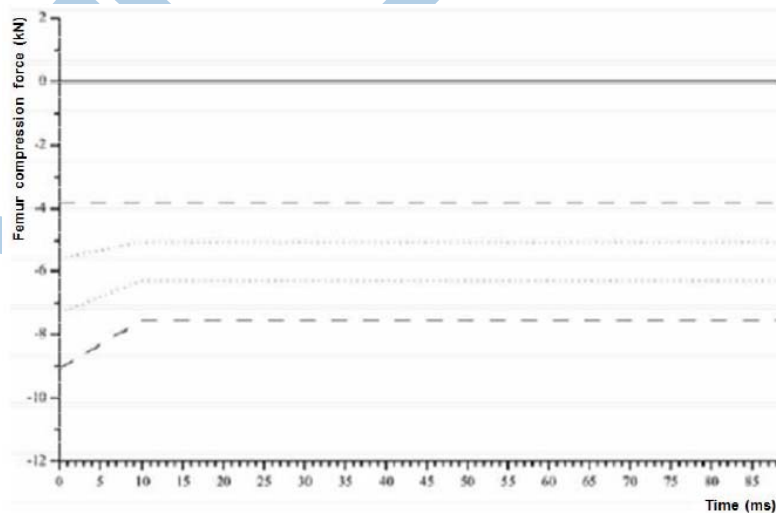

Figure 8 Femur compression force

1.2.1.1.1.5 Scoring of lower legs position

The maximum and minimum scores for this body area are 2 points and 0 point respectively.

The score for lower legs is generated by measuring relevant parameters of the dummy. The lower leg assessment parameters include the tibia index (TI) and lower legs compression force, which can each be awarded up to 2 points.

Higher performance limit:	Tibia index (TI)	0.4
	Lower legs compression force	2kN
Lower performance limit:	Tibia index (TI)	1.3
	Lower legs compression force	8kN

The lower performance limit and the higher performance limit correspond to 0 point and 2 points respectively. Between the two limits, the score is calculated by linear interpolation and rounded to two decimal places.

1.2.1.1.2 Scoring of second-row female dummy

To the maximum, the second-row female dummy may obtain 4 points, and to the minimum, 0 point. The scoring parts are head, neck and thorax of female dummy.

1.2.1.1.2.1 Scoring of head position

To the maximum, this part may obtain 1.6 points, and to the minimum, 0 point.

If the head of the second-row female dummy involves no secondary impact during the forward motion, 1.6 points will be obtained directly for such criterion; in case of secondary impact (against, e.g., seat, pillar-B, etc.) during the forward motion, the score for dummy head shall be resulted from measuring appropriate dummy criterion; the assessment criterion shall be the head injury criterion (HIC15); for this criterion, the maximum score is 1.6 points, which is calculated by the higher and lower performance limits.

Higher performance limit: Head injury criterion (HIC15) 500

Lower performance limit: Head injury criterion (HIC15) 700

Lower performance limit and higher performance limit correspond to 0 point and 1.6 points, respectively; for a measured value falling between them, the appropriate score shall be obtained by linear interpolation, which numeral shall be rounded to the second digit after the decimal point.

The aforesaid secondary impact is defined as follows: the head presents the trace of contact with vehicle components, and, according to Clause 5 to SAE J2052, the calculated head contact load exceeds 500N (excluding any secondary impact of the female dummy itself, e.g., between head and knee, between chin and thorax, etc.).

1.2.1.1.2.2 Scoring of neck position

For this part, the max.score is 0.4 points, and the min., 0 point. The neck score shall be obtained by measuring appropriate criteria of dummy neck. If the head of the second-row female dummy involves no secondary impact during the forward motion, the neck assessment criteria shall be the tension Fz, for which the maximum score is 0.4 points; if a secondary impact is involved, the neck assessment criteria shall be the shearing force Fx, tension Fz and extension bending moment My, each of which may get 0.4 points to the maximum.

Higher performance limits:	Shearing force Fx	1,200N
	Tension Fz	1,700N
	Extension bending moment My	36Nm
Lower performance limits:	Shearing force Fx	1,950N
	Tension Fz	2,620N

Extension bending moment M_y 49Nm

Lower performance limit and higher performance limit respectively correspond to 0 point and 0.4 points; for a measurement value falling within them, the score shall be calculated by means of linear interpolation, which shall be subsequently rounded off to 0.01.

For secondary impact, consult related descriptions in Paragraph 1.2.1.1.2.1.

1.2.1.1.2.3 Scoring of thorax position

The max.score for this part is 2 points, while the min. one is 0 point. The thorax score for the second-row female dummy is obtained by measuring related dummy criteria. The assessment criteria include compressive deformation.

Higher performance limit: Compressive deformation 23mm

Lower performance limit: Compressive deformation 48mm

Lower performance limit and higher performance limit respectively correspond to 0 point and 2 points; for a measurement value falling within them, the score shall be calculated by means of linear interpolation, which shall be subsequently rounded off to 0.01.

1.2.1.1.3 Electrical safety of battery electric vehicle/hybrid electric vehicle (EV/HEV)

1.2.1.1.3.1 Performance of protection against electrical shock

Evaluation indexes of performance of protection against electrical shock are divided into basic item (required item) and optional item (left to choice of any item). The basic item is insulation resistance at the side of rechargeable energy storage system (REESS); optional items are four items of low voltage, low electric energy, physical protection and insulation resistance at load side of power system, each high voltage bus should at least meet one of the four optional items. EV/HEV should meet both requirements of basic item and optional item at the same time.

1.2.1.1.3.1.1 Basic item

Measure the insulation resistance between the high voltage bus at REESS side and the electric chassis, the insulation resistance value measured or calculated in accordance with the stipulations of 1.12.5.1.1 should be more than or equivalent to $100\Omega/V$.

1.2.1.1.3.1.2 Optional item

1.2.1.1.3.1.2.1 Voltage safety

Within 5s-60s after end of the impact test, measure voltage V_b of the high voltage bus (voltage between the positive pole and the negative pole of the high voltage bus), V_1 (voltage between the negative pole of the high voltage bus and the electric chassis) and V_2 (voltage between the positive pole of the high voltage bus and the electric chassis) for multiple times in accordance with the stipulations of 1.12.5.1.2, the measured results of at least one group of V_b , V_1 and V_2 should be not more than 30V AC or 60V DC.

When impact test is performed under condition where REESS of vehicle is actively disconnected from power system load, this clause does not apply to the power system load.

1.2.1.1.3.1.2.2 Electric energy safety

Within 5s-60s after end of the impact test, measure the total electric energy TE of X-capacitor and the energy stored in the Y-capacitors (TE_{y1} , TE_{y2}) in accordance with the stipulations of 1.12.5.1.3, the measured and calculated values of TE and $TE_{y1}+TE_{y2}$ should be less than 0.2J.

When impact test is performed under condition where REESS of vehicle is actively disconnected from power system load, this clause does not apply to the power system load.

1.2.1.1.3.1.2.3 Physical protection

Physical protection measurement is divided into two parts of direct contact measurement and indirect contact measurement. The direct contact measurement is contact test of high voltage live parts of vehicle by using IPXXB test finger in accordance with the stipulations of 1.12.5.1.4.1; and the indirect contact measurement is to measure the resistance between exposed conductive parts and electric chassis in accordance with the stipulations of 1.12.5.1.4.2. IPXXB test finger for direct contact measurement during measurement test should not be in contact with high voltage live position, and resistance value of the indirect contact measurement should be lower than 0.1Ω . This requirement is deemed as satisfied if the galvanic connection has been established by welding.

1.2.1.1.3.1.2.4 Insulation resistance of load side of power system

After end of impact test, perform measurement of the insulation resistance between the high voltage bus at load side and the electric chassis in accordance with the stipulations of 1.12.5.1.5, and adopt different evaluation method of insulation resistance measurement results as per the galvanic connection or galvanic insulation between AC high voltage buses at load side and DC high voltage buses.

If AC high voltage buses and DC high voltage buses are galvanically isolated from each other, insulation resistance between the DC high voltage bus and the electric chassis should be more than or equivalent to $100\Omega/V$, and insulation resistance between the AC high voltage bus and the electric chassis should be more than or equivalent to $500\Omega/V$.

If AC high voltage buses and DC high voltage buses are galvanically connected, insulation resistance between the high voltage bus and the electric chassis should be more than or equivalent to $500\Omega/V$. If after impact, the protection level of all AC high voltage buses reaches IPXXB or AC voltage is equivalent to or less than 30V, then the insulation resistance between the high voltage bus at load side and the electric chassis should be more than or equivalent to $100\Omega/V$.

1.2.1.1.3.2 Electrolyte leakage

Within 30min after end of the impact, measure or inspect electrolyte leakage situations in accordance with the stipulations of 1.12.5.2. There should be no electrolyte spillage from the REESS into the occupant compartment, and there should be no more than 5L of electrolyte spilling from the REESS to the outside.

1.2.1.1.3.3 REESS safety evaluation

1.2.1.1.3.3.1 Position of REESS

REESS which is located inside the occupant compartment should remain in the installed location and REESS components should remain inside REESS enclosure; and no part of any REESS that is located outside the occupant compartment should enter the occupant compartment.

1.2.1.1.3.3.2 Fire or explosion of REESS

Within 30min after end of impact, REESS has no fire or explosion, it is deemed as safe.

1.2.1.1.3.4 High voltage automatic disconnection device

1.2.1.1.3.4.1 For vehicle installed with high voltage automatic disconnection device, manufacturer may determine whether to perform verification of the validity of the high voltage automatic disconnection device.

1.2.1.1.3.4.2 If manufacturer determines to perform verification test of the validity of the high voltage automatic disconnection device, verification test method can be determined through joint negotiation between manufacturer and C-NCAP Administration Center, and verification test results should be publicized.

1.2.1.1.4 Overall rating for the frontal impact test against the rigid barrier with 100%

overlapping

Given in Table 1 is the overall rating principle for the frontal impact test against the rigid barrier with 100% overlapping:

Table 1 Overall rating principle for the frontal impact test against the rigid barrier with 100% overlapping

Area	Penalty item		Area score	Overall rating	
Front-row dummy	Head	The score for the driver-side dummy's head is modified with 0~-1 for excessive upward displacement of the steering column.	0~5	0~20	
	Neck	-	0~2		
	Thorax	The score for the driver-side dummy's thorax is modified with 0~-1 for excessive rearward displacement of the steering column.	0~5		
	Upper	-	0~2		
	Lower	-	0~2		
	Restraint system	If front airbag (including lap airbag) is not completely deployed in the process of test, then deduct 1 point.			0, -1
		If seat system fails ¹ in the process of test, then deduct 1 point.			0, -1
If seat belt system fails ² in the process of test, then deduct 1 point.		0, -1			
Second-row female dummy	Head	-	0~1.6		
	Neck	-	0~0.4		
	Thorax	-	0~2		
	Restraint system	If seat system fails ³ in the process of test, minus 0.5 points or 1 point,		0, -0.5, -1	
If seat belt system fails ³ in the process of test, minus 0.5 points or 1 point,		0, -0.5, -1			
Second-row child dummy	Restraint system	1 point will be deducted in case of any failure with the anchorages for the CRS; ⁴	0, -1		
Overall penalty item	A minus one-point modifier will be applied for every door liable to open during the collision.		A maximum overall penalty of 4 points is available.		
	A minus one-point modifier will be applied for the restraint system if, when removing the dummy from the restraint system, the dummy is locked and the application of a force of over 60N on the release system cannot set it free.				
	A minus one-point modifier will be applied for the doors fitted corresponding to each row of seats on both sides of the vehicle, which fail to be opened without the use of any tools after the test.				
	A minus one-point modifier will be applied for vehicle featuring automatic locking function if locking function is not released after test of vehicle with door locked.				
	There is a penalty of two points if continuous leakage occurs in the fuel feeding system at an average rate of over 30g/min in the first 5min after the impact.				
Remark	For vehicle model with two-door and single-row seat, calculate score of the front row dummy only, and count score of the second row female dummy as full score (2 points) into total score of the item of test.				

Note 1: Seat failure includes complete fracture or disengagement of anchorage device, connection device, adjustment device, displacement folding device or locking device in the process of test or after test; but permanent deformation is allowed during impact process (such as partial fracture or generation of crack, etc).

Note 2: "Failure of adult safety belt" means any situation below occurring with the safety belt and restraint system:

- (1) Rupture of the strap;
- (2) Rupture/disengagement of the buckle, adjusting device or connector; or
- (3) Malfunction of the retractor;
- (4) Squib pre-tensioning phase of safety belt, which causes naked flame in occupant compartment.

Note 3: Subtract 1 point in case of failure of second row female dummy restraint system mentioned in remark 1 or remark 2; subtract 0.5 point in case of single side submarine of dummy pelvis due to reasons such as safety belt or seat; subtract 1 point in case of two sides submarine. Determine submarine of second row female dummy through dummy ilium force: it is determined as occurrence of submarine in case ilium force decreasing ratio is more than 1,000N/ms for 1ms of continuous duration during ilium force decreasing period ahead of dummy pelvis; or in case ilium force decreasing ratio is more than 1,000N/ms during pelvis bouncing phase, but with the exception of the circumstance where ilium force is less than 2,400N. Furthermore, where force applied on ilium is unstable, determine as per signal of complete unloading phase, and take video image taken

by onboard camera and lap belt force curve of safety belt as reference to assist confirmation.

Note 4: Child restraint system fixture failure means one of the following conditions:

- (1) Breakage or disengagement of the ISOFIX device when fixed with child restraint system;
- (2) When the child restraint system is fixed with the ISOFIX device, the head of the child dummy contacts the interior of the vehicle due to the second row seats or ISOFIX device, and the child dummy's head 3ms acceleration value exceeds 88g.

1.2.1.2 Fontal impact test against the deformable barrier with 40% overlapping

During the test, a maximum score is 20 points. For the assessment of the front-row dummy, the body regions of the test dummy are classified into four groups each of which can be awarded up to four points. The maximum score that can be obtained is 16 points. The grouped regions are:

- Group 1: Head, neck
- Group 2: Thorax
- Group 3: Knee, femur, pelvis
- Group 4: Lower leg, foot and ankle

For the assessment of the front-row dummy, the scoring shall be based on the injury criteria of the driver-side dummy. The scores of the occupant-side dummy may be validated only if they are less than the scores for corresponding areas of the driver-side dummy.

The maximum score for the second-row female dummy is 4 points; the body parts of the female dummy are divided into 2 groups; for each group, the maximum score is 2 points; concretely, neck and head constitute the first group (Group 1), and thorax, the second group (Group 2). The basic scoring principle for the adult dummies in the frontal row and the second row is: to set two limits for each parameter, a higher performance limit, threshold for a maximum score and a lower performance limit, threshold for zero point; the lowest point will be validated for a group where multiple-body region criteria exist; the lowest point will be validated for a body region where multiple criteria exist. The scores for all individual parameters shall be rounded to two decimal places.

1.2.1.2.1 Scoring of front-row dummy

1.2.1.2.1.1 Scoring of head and neck position (Group 1)

The sliding scale for this group is from 0 to 4 points.

1.2.1.2.1.1.1 Scoring of head position

The score for the occupant-side dummy's head is generated by measuring relevant parameters of the dummy, while the ultimate score for the driver-side dummy's head is obtained by subtracting the penalty for the deformation of the steering column from the score obtained herewith. The dummy head assessment parameters involve the head injury criteria (HIC36) and the resultant acceleration of 3ms. Each parameter can be awarded up to 4 points. The calculation is conducted by using the higher performance limit and the lower performance limit.

For the dummy's head ratings, higher and lower performance limits and score calculation method, see Paragraph 1.2.1.1.1.1.

With regard to the driver-side dummy, the score for head will be subject to modification with 0~-1, provided that excessive upward displacement of the steering column occurs. The EEVC recommending limit is 80mm. In calculating penalties, up to 90% of the EEVC limits (i.e., 72mm), there is no penalty. Beyond 110% of the EEVC limits (i.e., 88mm), there is a penalty of 1 point. The details are given below:

Upward displacement of steering column	Penalty
≤72mm	0

≥88mm

1

Between the two limits, the score is calculated by linear interpolation and rounded to two decimal places.

1.2.1.2.1.1.2 Scoring of neck position

The score for neck is obtained by measuring relevant parameters of the dummy's neck. The assessment parameters include shearing force F_x , tension F_z and extension bending moment M_y , which can each be awarded up to 4 points.

For the dummy's neck ratings, higher and lower performance limits and score calculation method, see Paragraph 1.2.1.1.1.2.

1.2.1.2.1.2 Scoring of thorax position (Group 2)

The sliding scale for this group is from 0 to 4 points.

The score for the occupant-side dummy's thorax is generated by measuring relevant parameters of the dummy, while the ultimate score for the driver-side dummy's thorax is obtained by subtracting the penalty for the deformation of the steering column and A-pillar from the score obtained herewith. The dummy thorax assessment parameters include the compressive deformation and the Viscosity Criterion (VC), each parameter can be awarded up to 4 points.

For the dummy's thorax ratings, higher and lower performances limits and score calculation method, see Paragraph 1.2.1.1.1.3.

With regard to the driver-side dummy, the score for thorax will be subject to modification with 0~-2 and 0~-1 for the excessive rearward displacement of the A-pillar and the steering column. Where the rearward displacement of the A-pillar is not in excess of 100mm, there is no penalty. In the case of the displacement being up to 200mm, there is a penalty of 2 points. The EEVC recommending limit for the rearward displacement of the steering column is 100mm. In calculating penalties, up to 90% of the EEVC limits (i.e., 90mm), there is no penalty. Beyond 110% of the EEVC limits (i.e., 110mm), there is a penalty of 1 point.

The details are given below:

Rearward displacement of A-pillar	Penalty
≤100mm	0
≥200mm	2

Rearward displacement of steering column	Penalty
≤90mm	0
≥110mm	1

Between the two limits, the score is calculated by linear interpolation and rounded to two decimal places.

1.2.1.2.1.3 Scoring of knee, femur, pelvis position (Group 3)

The sliding scale for this group is from 0 to 4 points.

The scores for these regions are obtained by measuring relevant parameters of the dummy. The assessment parameters include femur compression force and knee sliding displacement, which can each be awarded up to 4 points.

For ratings, higher and lower performance limits, and score calculation method, see Paragraph 1.2.1.1.1.4.

1.2.1.2.1.4 Scoring of lower leg, foot and ankle position (Group 4)

The sliding scale for this group is from 0 to 4 points.

The scores for these regions of the occupant-side dummy are generated by measuring relevant parameters of the dummy, while the ultimate scores for these regions of the driver-side dummy are obtained by subtracting the penalty for the deformation the pedals from the score obtained herewith. The assessment parameters include tibia index (TI) and tibia compression force, which can each be awarded up to 4 points.

For ratings, higher and lower performances limits and score calculation method, see Paragraph 1.2.1.1.1.5.

The scores for these regions of the driver-side dummy will be subject to modification with 0~-1 for the excessive rearward and upward displacements of pedals. In the following are the details:

Pedal rearward displacement	Penalty
≤100mm	0
≥200mm	1
Pedal upward displacement	Penalty
≤72mm	0
≥88mm	1

Between the two limits, the score is calculated by linear interpolation and rounded to two decimal places.

The penalty on the worst performing pedal shall be validated for all pedals of the vehicle.

Notes:

1. Pedal displacement is measured with no load applied to pedals.
2. If any of the pedals is so designed that it will be completely released from the mounting position during the impact, and it does fall from the mounting position but resulting in no perceptible resistance to the movement, no penalty will be taken into account.

1.2.1.2.2 Scoring of second-row female dummy

To the maximum, the second-row female dummy may obtain 4 points, and to the minimum, 0 point. The body parts of the female dummy are divided into 2 groups; for each group, the maximum score is 2 points; concretely, neck and head constitute the first group (Group 1), and thorax, the second group (Group 2).

1.2.1.2.2.1 Scoring of head and neck position (Group 1)

Max. score for this group is 2 points, and min. score, 0 point.

1.2.1.2.2.1.1 Scoring of head position

If the head of second-row female dummy involves no secondary impact during its forward motion, 2 points may be obtained directly; in case of any secondary impact with frontal seat, pillar-B, etc. during its forward motion, the score of dummy head shall be obtained through measuring dummy's pertinent criterion; the assessment criterion is head injury criterion (HIC15); the maximum score for this criterion is 2 points, which is calculated by means of higher performance limit and lower performance limit.

Lower performance limit and higher performance limit respectively correspond to 0 point and 2 points; for a measurement value falling within them, the score shall be calculated by means of linear interpolation, which shall be subsequently rounded off to 0.01.

For the higher and lower performance limits of dummy's head, and judgment procedures for secondary impact, refer to related text of Paragraph 1.2.1.1.2.1.

1.2.1.2.2.1.2 Scoring of neck position

Max. score for this part is 2 points, and min. score, 0 point.

Neck score is obtained by measuring related criteria of dummy's neck. If the head of second-row female dummy involves no secondary impact during its forward motion, the neck assessment criteria shall be tension Fz, for which the maximum score is 2 points; in case the head involves a secondary impact, the neck assessment criteria shall include shearing force Fx, tension Fz and extension bending moment My, each of which corresponds to 2 points to the maximum.

Lower performance limit and higher performance limit respectively correspond to 0 point and 2 points; for a measurement value falling within them, the score shall be calculated by means of linear interpolation, which shall be subsequently rounded off to 0.01.

For the higher and lower performance limits of dummy's neck and judgment procedures for secondary impact, refer to related text of Paragraph 1.2.1.1.2.2.

1.2.1.2.2 Scoring of thorax position (Group 2)

Max. score for this group is 2 points, and min. score, 0 point.

Thorax score of second-row female dummy shall be obtained by measuring related criteria of the dummy. The assessment criterion is represented by compressive deformation, for which 2 points may be obtained to the maximum.

Lower performance limit and higher performance limit respectively correspond to 0 point and 2 points; for a measurement value falling within them, the score shall be calculated by means of linear interpolation, which shall be subsequently rounded off to 0.01.

For the scoring of dummy thorax, higher and lower performance limits, and score calculation procedures, see related text in Paragraph 1.2.1.1.2.3.

1.2.1.2.3 Electrical safety of battery electric vehicle/hybrid electric vehicle (EV/HEV)

Electrical safety evaluation of EV / HEV is referring to 1.2.1.1.3.

1.2.1.2.4 Overall rating for the frontal impact test against the deformable barrier with 40% overlapping

Given in Table 2 is the overall rating principle for the frontal impact test against the deformable barrier with 40% overlapping:

Table 2 Overall rating principle for the frontal impact test against the deformable barrier with 40% overlapping

Group no.		Area	Penalty item	Area score	Overall rating
Front-row dummy	Group 1	Head, neck	The score for the driver-side dummy's head will be subject to modification with 0~-1 for the excessive upward displacement of the steering column.	0~4	0~20
	Group 2	Thorax	The score for the driver-side dummy's thorax will be subject to modification with 0~-2 and 0~-1 for the excessive rearward displacement of the A-pillar and the excessive rearward displacement of the steering column respectively.	0~4	
	Group 3	Knee, femur, pelvis	-	0~4	
	Group 4	Lower leg and foot and ankle	The scores for these regions of the driver-side dummy will be subject to modification with 0~-1 for the excessive rearward and upward displacements of pedals.	0~4	
	Restraint system		If front airbag (including lap airbag) is not completely deployed in the process of test, then deduct 1 point.	0, -1	
			If seat system fails ¹ in the process of test, then deduct 1 point.	0, -1	
			If seat belt system fails ² in the process of test, then deduct 1 point.	0, -1	
Second-row female dummy	Group 1	Head, neck	-	0~2	
	Group 2	Thorax	-	0~2	
	Restraint system		If seat system fails ³ in the process of test,, minus 0.5 points or 1 point,	0, -0.5, -1	

		If seat belt system fails ³ in the process of test, minus 0.5 points or 1 point,	0, -0.5, -1	
Overall penalty item	A minus one-point modifier will be applied for every door liable to open during the impact.		A maximum overall penalty of 4 points is available.	
	A minus one-point modifier will be applied for the restraint system if, when removing the dummy from the restraint system, the dummy is locked and the application of a force of over 60N on the release system cannot set it free.			
	A minus one-point modifier will be applied for the doors fitted corresponding to each row of seats on both sides of the vehicle, which fail to be opened without the use of any tools after the test.			
	A minus one-point modifier will be applied for vehicle featuring automatic locking function if locking function is not released after test of vehicle with door locked.			
	There is a penalty of 2 points if continuous leakage occurs in the fuel feeding system at an average rate of over 30g/min in the first 5min after the impact.			
Remark	For vehicle model with two-door and single-row seat, calculate score of the front row dummy only, and count score of the second row female dummy as full score (2 points) into total score of the item of test.			

Note 1: Seat failure includes complete fracture or disengagement of anchorage device, connection device, adjustment device, displacement folding device or locking device in the process of test or after test; but permanent deformation is allowed during impact process (such as partial fracture or generation of crack, etc).

Note 2: "Failure of adult safety belt" means any situation below occurring with the safety belt and restraint system:

- (1) Rupture of the strap;
- (2) Rupture/disengagement of the buckle, adjusting device or connector; or
- (3) Malfunction of the retractor;
- (4) Squib pre-tensioning phase of safety belt, which causes naked flame in occupant compartment.

Note 3: Subtract 1 point in case of failure of second row female dummy restraint system mentioned in remark 1 or remark 2; subtract 0.5 point in case of single side submarine of dummy pelvis due to reasons such as safety belt or seat; subtract 1 point in case of two sides submarine. Determine submarine of second row female dummy through dummy ilium force: it is determined as occurrence of submarine in case ilium force decreasing ratio is more than 1,000N/ms for 1ms of continuous duration during ilium force decreasing period ahead of dummy pelvis; or in case ilium force decreasing ratio is more than 1,000N/ms during pelvis bouncing phase, but with the exception of the circumstance where ilium force is less than 2,400N. Furthermore, where force applied on ilium is unstable, determine as per signal of complete unloading phase, and take video image taken by onboard camera and lap belt force curve of safety belt as reference to assist confirmation.

1.2.1.3 Side impact test against the mobile deformable barrier

For the test, a maximum score of 20 points is available. For the front-row dummy, a maximum score of 16 points may be obtained; the dummy body regions to be rated include head, thorax, abdomen and pelvis which can each be awarded up to 4 points. For the second-row female dummy, a maximum score of 4 points may be obtained, and the scoring parts are dummy's head, chest, abdomen and pelvis, for each of which the maximum score is 1 point.

For the adult dummies in the frontal row and the second row, the basic scoring principle for each dummy is: to set higher performance limit and lower performance limit, corresponding to the maximum score and 0 point of each body part; the lowest point will be validated for a body region where multiple criteria exist. The scores for all individual parameters shall be rounded to two decimal places.

1.2.1.3.1 Scoring of front-row dummy

1.2.1.3.1.1 Scoring of head position

The sliding scale for this body region is from 0 to 4 points.

The score for the dummy's head is generated by measuring relevant parameters of the dummy. The assessment parameters include the head injury criterion (HIC15) and the resultant acceleration of 3ms which can each be awarded up to 4 points. Higher and lower performance limits are to be used for calculation.

Higher performance limits: Head injury criterion (HIC36) 500
Resultant acceleration of 3ms 72g

Lower performance limits:	Head injury criterion (HIC36)	700
	Resultant acceleration of 3ms	80g

Lower performance limit and higher performance limit respectively correspond to 0 point and 4 points; for a measurement value falling within them, the score shall be calculated by means of linear interpolation, which shall be subsequently rounded off to 0.01.

1.2.1.3.1.2 Scoring of chest position

The sliding scale for this body region is from 0 to 4 points.

The score for the dummy's thorax is generated by measuring relevant parameters of the dummy. The assessment parameter is the compressive deformation of chest rib which can each be awarded up to 4 points. Higher and lower performance limits are to be used for calculation.

Higher performance limits: Compressive deformation 28mm

Lower performance limits: Compressive deformation 50mm

Lower performance limit and higher performance limit respectively correspond to 0 point and 4 points; for a measurement value falling within them, the score shall be calculated by means of linear interpolation, which shall be subsequently rounded off to 0.01.

If one of the following occurs, the chest cannot score:

- a) Shoulder lateral force (Y direction) is more than or equivalent to 3kN;
- b) Chest Rib VC value is more than or equivalent to 1.0m/s.

1.2.1.3.1.3 Scoring of abdomen position

The sliding scale for this body region is from 0 to 4 points.

The score for the dummy's abdomen is generated by measuring relevant parameters of the dummy. The assessment parameter is the compressive deformation of abdomen rib which can each be awarded up to 4 points. Higher and lower performance limits are to be used for calculation.

Higher performance limit: Compressive deformation 47mm

Lower performance limit: Compressive deformation 65mm

If the abdomen rib VC value is more than or equivalent to 1.0m / s, the abdomen cannot score.

The lower performance limit and the higher performance limit correspond to 0 point and 4 points respectively. Between the two limits, the score is calculated by linear interpolation and rounded to two decimal places.

1.2.1.3.1.4 Scoring of pelvis position

The sliding scale for this body region is from 0 to 4 points.

The score for the dummy's pelvis is generated by measuring relevant parameters of the dummy. The pubis force is subject to assessment. A maximum score of 4 points is available for it. Higher and lower performance limits are to be used for calculation.

Higher performance limit: Pubis force 1.7kN

Lower performance limit: Pubis force 2.8kN

The lower performance limit and the higher performance limit correspond to 0 point and 4 points respectively. Between the two limits, the score is calculated by linear interpolation and rounded to two decimal places.

1.2.1.3.2 Scoring of second-row female dummy

For the second-row female dummy, limits are set for the performance criteria of dummy's head, chest, abdomen and pelvis, with each body part corresponding to 1 point. Head assessment criterion is assumed by head injury criterion (HIC15), while pelvis assessment criterion, by resultant pelvis force.

1.2.1.3.2.1 Scoring of head position

Maximum score for this part is 1 point, and minimum score, 0 point.

Score of dummy head is resulted from measuring dummy's related criterion; its assessment criterion is assumed by head injury criterion (HIC15), which corresponds to 1 point to the maximum, and is calculated by means of higher performance limit and lower performance limit.

Lower performance limit and higher performance limit respectively correspond to 0 point and 1 point; for a measurement value falling within them, the score shall be calculated by means of linear interpolation, which shall be subsequently rounded off to 0.01.

For the higher and lower performance limits, consult the pertinent text in Paragraph 1.2.1.1.2.1.

1.2.1.3.2.2 Scoring of chest position

The sliding scale for this body region is from 0 to 1 point.

The score for the dummy's abdomen is generated by measuring relevant parameters of the dummy. The assessment parameter is the compressive deformation of chest rib which can each be awarded up to 1 point. Higher and lower performance limits are to be used for calculation.

Higher performance limit:	Compressive deformation	31mm
Lower performance limit:	Compressive deformation	41mm

The lower performance limit and the higher performance limit correspond to 0 point and 1 point respectively. Between the two limits, the score is calculated by linear interpolation and rounded to two decimal places.

If the chest rib VC value is more than or equivalent to 1.0m / s, the chest cannot score.

1.2.1.3.2.3 Scoring of abdomen position

The sliding scale for this body region is from 0 to 1 point.

The score for the dummy's abdomen is generated by measuring relevant parameters of the dummy. The assessment parameter is the compressive deformation of abdomen rib which can each be awarded up to 1 point. Higher and lower performance limits are to be used for calculation.

Higher performance limit:	Compressive deformation	38mm
Lower performance limit:	Compressive deformation	48mm

The lower performance limit and the higher performance limit correspond to 0 point and 4 points respectively. Between the two limits, the score is calculated by linear interpolation and rounded to two decimal places.

If the abdomen rib VC value is more than or equivalent to 1.0m / s, the abdomen cannot score.

1.2.1.3.2.4 Scoring of pelvis position

Maximum score for this part is 1 point, and minimum score, 0 point.

Score of dummy pelvis is resulted from measuring dummy's related criterion; its assessment criterion is assumed by resultant pelvis force (synthetic force of hip joint and iliac bone), which corresponds to 1 point to the maximum, and is calculated by means of

higher performance limit and lower performance limit.

Higher performance limit: Resultant pelvis force 3.5kN

Lower performance limit: Resultant pelvis force 5.5kN

Lower performance limit and higher performance limit correspond to 0 point and 1 point, respectively; for a measurement value falling between them, the score shall be computed by means of linear interpolation, which shall be subsequently rounded off to 0.01.

1.2.1.3.3 Electrical safety of battery electric vehicle/hybrid electric vehicle (EV/HEV)

Electrical safety evaluation of EV / HEV is referring to 1.2.1.1.3.

1.2.1.3.4 Overall rating for the side impact test against the mobile deformable barrier

The overall rating principle for the side impact test against the mobile deformable barrier is set out in Table 3.

Table 3 Overall rating principles for the side impact test against the mobile deformable barrier

Area	Penalty item	Area score	Overall rating
Front-row dummy	Head	-	0~4
	Chest	Chest score is 0 when shoulder lateral force is more than or equivalent to 3kN. Chest score is 0 when chest rib VC is more than or equivalent to 1.0m/s.	0~4
	Abdomen	Abdomen score is 0 when abdomen rib VC is more than or equivalent to 1.0m/s	0~4
	Pelvis	-	0~4
	Restraint system	If side airbag is not completely deployed in the process of test, then deduct 1 point. If seat belt system fails in the process of test, then deduct 1 point.	0, 1 0, -1
Second-row female dummy	Head	-	0~1
	Chest	Chest score is 0 when chest rib VC is more than or equivalent to 1.0m/s.	0~1
	Abdomen	Abdomen score is 0 when abdomen rib VC is more than or equivalent to 1.0m/s	0~1
	Pelvis	-	0~1
	Restraint system	If side airbag is not completely deployed in the process of test, then deduct 1 point. If seat belt system fails in the process of test, then deduct 1 point.	0, -1 0, -1
Overall penalty item	A minus one-point modifier will be applied for every door liable to open during the impact. A minus one-point modifier will be applied for vehicle featuring automatic locking function if locking function of non-collision side door is not released after test of vehicle with door locked. When a dummy is released from the restraint system, if seatbelt is locked and has not been unlocked by applying a pressure force more than 60N on release device, then subtract 1 point respectively There is a penalty of 2 points if the continuous leakage occurs in the fuel feeding system at an average rate of over 30g/min in the first 5min after the impact.	A maximum overall penalty of 4 points is available.	0~20
Remark	For vehicle model with two-door and single-row seat, calculate score of the front row dummy only, and count score of the second row female dummy as full score (2 points) into total score of the item of test.		

1.2.1.4 Whiplash test

Maximum score for the whiplash test is 5 points, and the scoring is based on the injury criteria measured through transducers installed on the dummy; dummy measuring data comprise three sets: one set represents the neck injury criterion calculated from head acceleration and thorax acceleration, and the maximum score is 2 points; the second set

is represented by upper neck load and torque, for which the maximum score is 1.5 points; the third set is represented by lower neck load and torque, for which the maximum score is 1.5 points. The scoring is based on dummy injury criteria; for each injury criterion, both higher and lower performance limits are established, corresponding to the maximum score and 0 point respectively; for a value falling between them, the score shall be calculated by means of linear interpolation, and the score of each test item shall be rounded off to 0.01. For this test, penalty of 2 points, 2 points and 5 points shall apply respectively in case of non-conformity below: maximum dynamic flare angle of seat back, head interference space of head restraint, and seat track dynamic displacement.

1.2.1.4.1 Neck injury criterion (NIC)

For this group, the maximum score is 2 points, and the minimum score, 0 point. Scoring shall be resulted from the measurement of dummy head acceleration and thorax T1 acceleration. Through calculation, the neck injury criterion (NIC) can be obtained.

Higher performance limit: $8\text{m}^2/\text{s}^2$

Lower performance limit: $30\text{m}^2/\text{s}^2$

Lower performance limit and higher performance limit correspond to 0 point and 2 points, respectively; for a value falling between them, the score shall be calculated by means of linear interpolation, and the score of each test item shall be rounded off to 0.01.

1.2.1.4.2 Upper neck load and torque

Maximum score for this group is 1.5 points, and minimum score, 0 point. The scoring is based on the measurement of related criteria of dummy upper neck, including upper neck shearing force F_{x+} , upper neck tension F_{z+} and upper neck torque M_y . Calculate score of all indexes respectively, and take the lowest value of three items of score as the score of the group.

Higher performance limits:	Upper neck shearing force F_{x+}	340N
	Upper neck tension F_{z+}	475N
	Upper neck torque M_y	12Nm
Lower performance limits:	Upper neck shearing force F_{x+}	730N
	Upper neck tension F_{z+}	1,130N
	Upper neck torque M_y	40Nm

Lower performance limit and higher performance limit correspond to 0 point and 1.5 points, respectively; for a measurement value falling between them, the score shall be computed by means of linear interpolation, which shall be subsequently rounded off to 0.01.

1.2.1.4.3 Lower neck load and torque

Maximum score for this group is 1.5 points, and minimum score, 0 point. The scoring is based on the measurement of related criteria of dummy lower neck, including lower neck shearing force F_{x+} , lower neck tension F_{z+} and lower neck torque M_y . Calculate score of all indexes respectively, and take the lowest value of three items of score as the score of the group.

Higher performance limits:	Lower neck shearing force F_{x+}	340N
	Lower neck tension F_{z+}	257N
	Lower neck torque M_y	12Nm
Lower performance limits:	Lower neck shearing force F_{x+}	730N
	Lower neck tension F_{z+}	1,480N

Lower neck torque My

40Nm

Lower performance limit and higher performance limit correspond to 0 point and 1.5 points, respectively; for a measurement value falling between them, the score shall be computed by means of linear interpolation, which shall be subsequently rounded off to 0.01.

1.2.1.4.4 Penalty items for whiplash test

1.2.1.4.4.1 Seat back dynamic flare angle

For this item, the maximum penalty score is 2 points. Based on image analysis, the maximum variation of seat back flare angle is obtained during the impact; the limit for this item is 25.5°. No penalty score applies for a value below such limit, i.e., 0 point is obtained; 2 points shall be deducted if such limit is exceeded or equaled, i.e., -2 points are obtained.

1.2.1.4.4.2 Head interference space of head restraint

For this item, the maximum penalty score is 2 points. In the course of seat adjustment and measurement, 2 points shall be deducted if HRMD measurement is interfered by the head restraint, i.e., -2 points are obtained.

1.2.1.4.4.3 Seat track dynamic displacement

For this item, the maximum penalty score is 5 points. Based on the high-speedvideo data, 5 points shall be deducted if the maximum dynamic displacement of track in relation to fixed part exceeds or equals to 20mm in the course of dynamic impact, i.e., -5 points are obtained.

1.2.1.4.5 Overall scoring of whiplash test

The minimum score for the whiplash test is 0 point. It will not be negative score due to penalty score. Table 4 presents the overall scoring principles for the whiplash test:

Table 4 Overall scoring principles for whiplash test

Criteria	Higher performance limit	Lower performance limit	Score	Score of whiplash test
NIC	8m2/s2	30m2/s ²	0~2	0~5
Upper neck Fx+	340N	730N	0~1.5	
Upper neck Fz+	475N	1130N		
Upper neck My	12N·m	40N·m		
Lower neck Fx+	340N	730N	0~1.5	
Lower neck Fz+	257N	1480N		
Lower neck My	12N·m	40N·m		
Seat back dynamic flare angle	≥25.5°		-2	
Head interference space of head restraint	Y		-2	
Seat track dynamic displacement	≥20mm		-5	

1.2.2 Bonus items

A maximum bonus of 5 points is available.

1.2.2.1 Safety belt reminder

1.2.2.1.1 General provisions

1.2.2.1.1.1 For vehicle configured with seat belt reminder, if the performance of reminder meets the specified technical requirements, then relevant points can be awarded, a maximum of 2 points is awarded for the item.

1.2.2.1.1.2 For the passenger position of front row, if seat belt reminder and passenger presence detection function are available at the same time, then 1 point will be awarded; if only seat belt reminder is available, then 0.5 point is awarded.

1.2.2.1.1.3 For the positions of second row, when all seating positions are configured with seat belt

reminder and specific seating position can be distinguished in reminding signal (no requirement for passenger presence detection function), then 1 point is awarded.

1.2.2.1.2 Requirements on reminding signal

1.2.2.1.2.1 Reminding signal is visual or aural signal; the display position should enable driver to see clearly at normal driving position.

1.2.2.1.2.2 Phonetic information or conspicuous image (or text) information on LCD can be used.

1.2.2.1.2.3 Visual signal should be sufficiently bright so that it is clearly visible under sunlight and can be distinguished from other reminding signal.

1.2.2.1.2.4 Aural signal should be loud and clear, can be continuous or intermittent, and can consist of several tempos of different sound intensities. For intermittent signal, the duration of interval should not exceed 30s.

1.2.2.1.2.5 Visual or aural signal duration time should be not less than 30s, but excluding break above 3s.

1.2.2.1.2.6 If safety belt is still unfastened after a specified duration time, visual or aural signal can be turned off automatically.

1.2.2.1.3 Activation condition

If occupant does not fasten seat belt, safety belt reminder should be activated. During vehicle running process, after reminding signal is turned off, if safety belt use conditions change at any seat position of the front row and the 2nd row (safety belt is unfastened), the reminding signal should be reactivated.

1.2.2.1.3.1 Front seat occupant position

Work mode includes early reminding and latter reminding.

1.2.2.1.3.1.1 Early reminding

Ignition switch is at "on" position (regardless whether engine is in operating status), signal should be activated with duration not less than 4s.

1.2.2.1.3.1.2 Latter reminding

The reminding signal should be activated when vehicle is under one of the following conditions:

- a) The vehicle engine (or driving motor) has run for more than 60s;
- b) The vehicle has moved forward with 60s;
- c) The vehicle has moved forward with 500m;
- d) The vehicle has reached a forward speed exceeding 25km/h.

1.2.2.1.3.2 The 2nd row occupant position

The reminding signal must be activated within 5s under at least one of the following conditions of engine (or driving motor) start or the vehicle running forward speed exceeding 10km/h. When seat use condition includes monitoring function, the activation time of signal can be delayed.

1.2.2.2 Curtain airbag

1.2.2.2.1 General provisions

1.2.2.2.1.1 Must be the front and rear integrated curtain airbag.

1.2.2.2.1.2 Front row side airbag must be configured at the same time.

1.2.2.2.1.3 If the performances of external dimensions, deployment mode and dynamic protection of curtain airbag in side impact test meet the specified technical requirement, relevant

additional points can be awarded. In which, 1 point is set for each item of the performance and the maximum score is 3 points.

1.2.2.2.1.4 Assessment is performed at driver's side. After test, deploy side curtain airbag at the 1st row passenger side and perform auxiliary assessment.

1.2.2.2.1.5 In case of asymmetry between two sides due to differences of curtain airbag structure and installation position, it is necessary to evaluate separately and the final assessment will be based upon the worst performing part of any of the airbags.

1.2.2.2.2 External dimensions

Curtain airbag should cover the seating positions from the front row to the 3rd row (if any). For the 3rd row seats which are removable or movable/foldable, or seats not suitable for adult (it should be clarified in user's manual), it is only required to cover to the 2nd row seating positions.

1.2.2.2.2.1 Evaluation zone

1.2.2.2.2.1.1 Curtain airbag should cover evaluation zones of all rows (with the exception of areas corresponding to side wall top part, B-pillar, C-pillar and door waist line).

1.2.2.2.2.1.2 HPM evaluation zone is a quadrilateral with round corners. The centers of the circle of four round corners are defined through the coordinate of center of gravity (CoG) of dummy head, as shown in Figure 9.

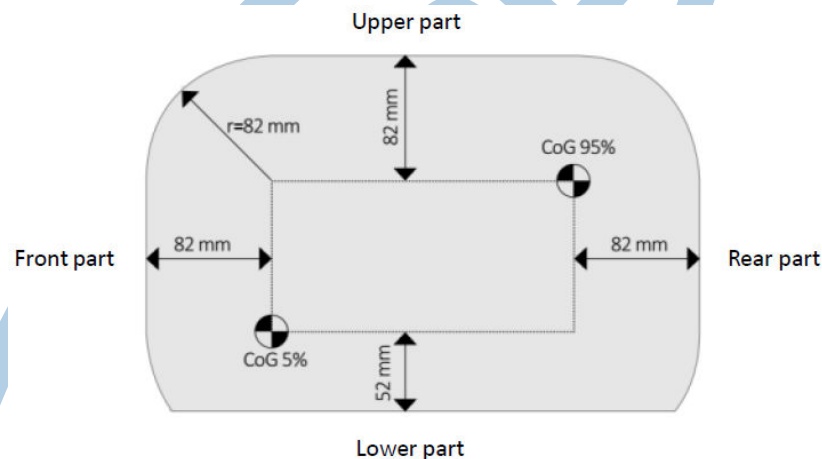

Figure 9 Schematic diagram of HPM evaluation zone

1.2.2.2.2.1.3 Head CoG position is defined in relation to H-point of 50% dummy, as shown in Figure 10, see the determination procedure of H-point as per 3.6.1 in Chapter 4. For the front row seats, the H-point is determined in 3.6.1.1.12; for the 2nd and 3rd seats, the H-point is determined in 3.6.1.2.9.

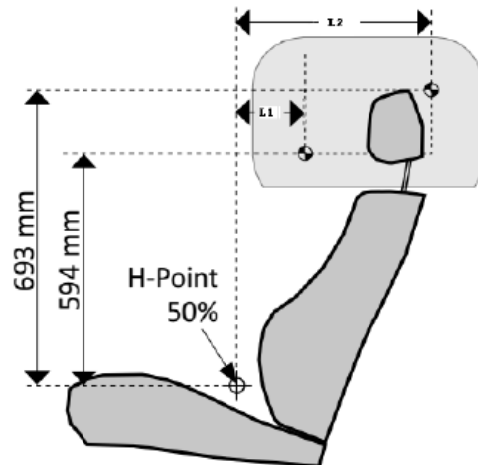

Figure 10 Schematic diagram of head CoG position definition

For front row seat: 5% female head CoG:

$X_{CoG,5th} = H\text{-point}(X) + 126\text{mm}$ – travel along horizontal direction of seat (seat 5% human body design position to position 20mm rearwards from center of seat travel)

$Z_{CoG,5th} = H\text{-point}(Z) + 594\text{mm}$

95% male head CoG:

$X_{CoG,95th} = H\text{-point}(X) + 147\text{mm}$ + travel along horizontal direction of seat (position 20mm rearwards from center of seat travel to seat 95% human body design position)

$Z_{CoG,95th} = H\text{-point}(Z) + 693\text{mm}$

For the 2nd and the 3rd row seats: 5% female head CoG at the foremost seat position:

$X_{CoG,5th} = H\text{-point}(X) + 126\text{mm}$ – travel along horizontal direction of seat (the foremost of seat travel to central position)

$Z_{CoG,5th} = H\text{-point}(Z) + 594\text{mm}$

95th percentile male head CoG at the rearmost seat position:

$X_{CoG,95th} = H\text{-point}(X) + 147\text{mm}$ + travel along horizontal direction of seat (central position of seat to rearmost position)

$Z_{CoG,95th} = H\text{-point}(Z) + 693\text{mm}$

1.2.2.2.2 Seams line area

The dimensions and design position of stitching line area in the curtain airbag evaluation zone should meet the following requirements:

- Width between non-inflated areas should not exceed 15mm;
- Diameter of non-inflated areas (or equivalent area) should be not more than 50mm;
- When static deployment of curtain airbag is evaluated, airbag should be under effective inflated status when air pressure in airbag is under the pressure recommended by manufacturer or 0.3bar~0.4bar.

1.2.2.2.3 Deployment mode

1.2.2.2.3.1 There should be no situations such as hitching, cracking, jamming and so forth.

1.2.2.2.3.2 After falling off or rupture of interior trim parts, there should be no features such as sharp edge, sharp angle and burr that may injure occupant.

1.2.2.2.3.3 There should be no hard splashes (such as hard plastic scrap and metal scrap, etc); the maximum allowable weight of single piece of soft splashes (such as separating foam block of vertical Pilar and so forth) is 3g and the maximum allowable total weight is 5g.

1.2.2.2.4 Dynamic protection

During side impact process of curtain/side airbag deployment, the dummy head contact position of front row and the 2nd row shall fall within the inflation zone of side curtain airbag (stitching line area should meet the requirements of 1.2.2.2.2.2).

2 Pedestrian protection

2.1 Test items

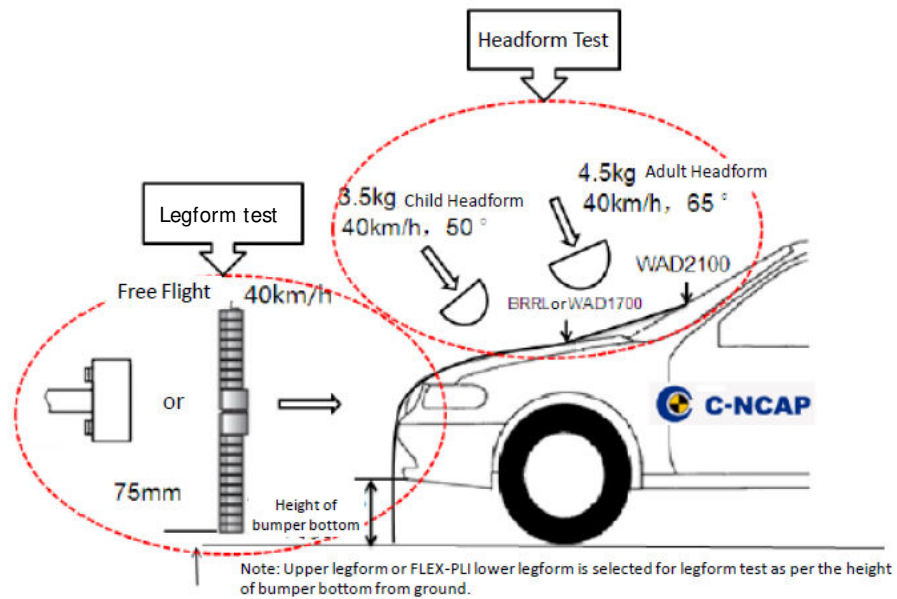

Figure 11 Pedestrian protection test

Pedestrian protection test item includes headform test and legform test, so as to respectively evaluate headform test zone and legform test zone of vehicle, as shown in Figure 11. Adult headform or child headform is selected for headform test by taking WAD1700 wrap around line (or bonnet rear reference line) as boundary in accordance with vehicle structure characteristics, and the specified position of vehicle headform test zone is impacted; upper legform or FLEX-PLI lower legform is selected for legform test as per the height of bumper bottom from ground, and the specified position of legform test zone is impacted.

2.1.1 Headform test

Adjust vehicle to normal ride attitude, with headform impacting vehicle headform test zone at speed of $40^{+0.72}_{-0.72}$ km/h, and evaluate the impact protection performance of vehicle for pedestrian head. Headform test is divided into child headform test and adult headform test, the impact angle is $50^{\circ} \pm 2^{\circ}$ when child headform is used for test, and the impact angle is $65^{\circ} \pm 2^{\circ}$ when adult headform is used for test. Headform should be under free flight condition upon the moment of impact, and deviation of test point impact position should be not more than ± 10 mm. In test, calculate HIC₁₅ value through acquisition of acceleration along three directions of headform in collision process, so as to evaluate impact protection performance of vehicle for pedestrian head.

2.1.2 Legform test

2.1.2.1 Lower legform test (FLEX-PLI test)

Adjust vehicle to normal ride attitude, with lower legform impacting vehicle front legform test zone horizontally at speed of $40^{+0.72}_{-0.72}$ km/h, and evaluate impact protection performance of vehicle for pedestrian leg. The lower legform should be under free flight condition at the moment of impact, velocity vector should be within horizontal plane and vehicle longitudinal vertical plane, the angle deviation should be not more than $\pm 2^\circ$, and deviation of rotation angle of lower legform around its vertical axis shall be not more than $\pm 2^\circ$, and the bottom of lower legform should be within the scope of $75\text{mm} \pm 10\text{mm}$ above ground reference plane. During test, 7 indexes such as 4 bending moments of tibia and MCL, ACL and PCL of knee ligament elongation are collected during impact process, so as to evaluate impact protection performance of vehicle for pedestrian leg.

2.1.2.2 Upper legform test

Adjust vehicle to normal ride attitude, with upper legform impacting vehicle front legform test zone horizontally at speed of $40^{+0.72}_{-0.72}$ km/h, and evaluate impact protection performance of vehicle for pedestrian leg. The upper legform should be linearly guided at the moment of impact, velocity vector should be within horizontal plane of vehicle and longitudinal vertical plane of vehicle, the angle deviation should be not more than $\pm 2^\circ$. During test, 5 indexes such as 2 impacting force values and 3 bending moments are collected during impact process, so as to evaluate impact protection performance of vehicle for pedestrian leg.

2.2 Performance index and scoring method









Evaluation of pedestrian protection includes evaluation of vehicle headform test zone and legform test zone. The maximum available score is 15 points, in which, the maximum available score for headform test zone is 12 points and the maximum available score for legform test zone is 3 points.

2.2.1 Headform test zone

The maximum available score for headform test zone is 12 points and equal width the minimum score is 0 point. Headform test zone is divided into several grid points or areas, the maximum awarded score for each grid point or area is 1.000 and the minimum awarded score is 0.000. Head evaluation index is HIC_{15} , 5 areas are set as per head evaluation index HIC_{15} value, each area corresponds to different score points, and is indicated by different colors, see Table 5. Sum of awarded score of all grid points or areas in headform test zone is divided by maximum awarded score of all grid points or areas to obtain percentage of headform test score. The percentage is multiplied by 12 to get the final score of headform test zone, and the score is rounded to 3 decimal places.

As per the situation whether vehicle manufacturer provides components such as bonnet required for test and predicated results of headform test zone as per requirement, perform headform test and scoring as per the specified grid point method or equivalent area division method.

Table 5 Determination condition of predicted results of headform test zone

Predicated results	Color	Score points	
"Default predicated results grid point"	Default green 	1.000	
	Default red 	0.000	
"Unpredictable results grid point"	Blue 	To be determined by headform test results	
"Specific predicated results grid point" or "headform test result"	$\text{HIC}_{15} < 650$	Green 	1.000
	$650 \leq \text{HIC}_{15} < 1,000$	Yellow 	0.750
	$1,000 \leq \text{HIC}_{15} < 1,350$	Orange 	0.500
	$1,350 \leq \text{HIC}_{15} < 1,700$	Brown 	0.250
	$1,700 \leq \text{HIC}_{15}$	Red 	0.000

2.2.1.1 Grid point method

If vehicle manufacturer provides components such as bonnet required for test and predicated results of headform test zone as per requirement, then perform test and scoring as per this method.

Prior to test, vehicle manufacturer should provide predicated results of all grid points as per the mode of color distribution (or HIC₁₅ value) to C-NCAP Administration Center, see Figure 12. The predicated results can be divided into three parts, “specific predicated results grid point”, “default predicated results grid point” and “unpredictable results grid point”. When predicated result contains “unpredictable results grid point”, vehicle manufacturer should provide evidence for difficulty of prediction at the same time, and number of blue areas should not exceed 8, and symmetrical position area can be deemed as 1.

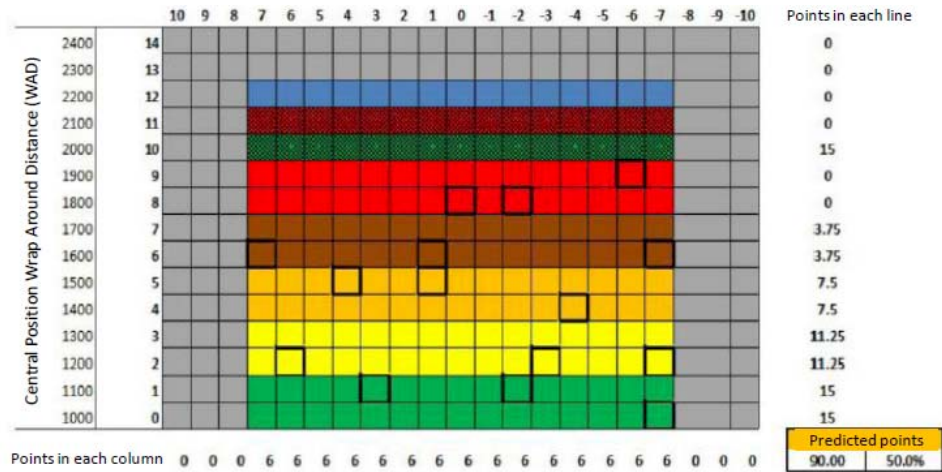

Figure 12 Schematic diagram of predicated results of headform test

During test evaluation, for “specific predicated results grid point”, C-NCAP Test Evaluation Department randomly takes 8 grid points for test verification, finally sum of score obtained at the verification test points is divided by sum of score of the predicated results at corresponding points to calculate correction factor, the correction factor is used to correct the predicated results of all grid points (with predicated results), then the corrected result is used as score for calculation of evaluation results. When the correction factor is in the scope of 0.75-1.25, it is deemed that the correction factor is acceptable. If the correction factor is more than 1.25, the correction factor is “1”; if the correction factor is in the scope of 0.5-0.75, the correction factor is deducted by 0.2; if the correction factor is less than 0.5, then the correction factor is “0”. For “default predicated results grid point”, directly take it as score for calculation of evaluation results. For “unpredictable results grid point”, C-NCAP Test Evaluation Department selects the grid point potentially causing large injury to pedestrian from each blue area for test, obtains relevant score in accordance with test result HIC₁₅ value as per Table 5, multiplies it by number of grid points in the blue area, and it is used as score for calculation of evaluation results.

There are differences between test results of different laboratories and between test results and simulation results, tolerance of $\pm 10\%$ of verification test HIC₁₅ value is allowed, and the tolerance is only used for verification of correctness of predicated color of grid point. See the determination interval with consideration of tolerance as per the following Table 6. If the color of verification test is identical with the predicated color, then the predicated result color and relevant score are obtained for the point. If the color of verification test is not consistent with the predicated color, then the test result color of the grid point and relevant score are obtained in accordance with verification test HIC₁₅ value as per Table 5.

Table 6 Determination condition of verification test result of allowable tolerance

HIC ₁₅ interval	Color
HIC ₁₅ < 722.22	Green ■
590.91 ≤ HIC ₁₅ < 1,111.11	Yellow ■
909.09 ≤ HIC ₁₅ < 1,500	Orange ■
1,227.27 ≤ HIC ₁₅ < 1,888.89	Brown ■

When manufacturer deems that it is necessary to add number of test points, so as to acquire more accurate assessment results, manufacturer may propose to add test points, the additional test points should not exceed 8, and should be proposed upon submitting of predicated results, C-NCAP Test Evaluation Department randomly selects the additional test point position as per color distribution proportion.

2.2.1.2 Equal width area method

If vehicle manufacturer has not provided components such as bonnet required for test or predicated results of headform test zone as per requirement, then perform test and scoring as per the following method.

2.2.1.2.1 Manufacturer has not provided the predicated results of headform test zone

Divide headform test zone into 12 equal width areas, and divide each equal width area into four quarters. During test process, selects 1 grid point potentially causing large injury to pedestrian from each equal width area for test. The awarded score of each test point is obtained in accordance with test result as per the determination condition of Table 5, The awarded score of the quarter which the test point locates in obtains the awarded score of test point. The awarded score of the other quarters locating in the equal width area obtain the score of the quarter. For equal width areas of symmetrical structure, it is allowed to select any side for test and scoring. For equal width areas without test point, the score of symmetrical equal width areas is awarded.

When manufacturer deems that it is necessary to add number of test points, so as to acquire more accurate assessment results, manufacturer may propose to add test points, the additional test points should not exceed 8. When it is necessary to add test points, it is necessary to propose upon submitting of vehicle test information and indicate the distribution of assessment quarters of these newly added test points. For equal width areas in which manufacturer applies to add test points, respectively selects 1 point potentially causing large injury to pedestrian from quarter(s) in which evaluation is specified for additional test point and quarter(s) in which no evaluation is specified for additional test point. Respectively obtain score for two test points as per the determination condition of Table 5, and respectively assign score to quarter(s) in which evaluation is specified for additional test points and quarter(s) in which no evaluation is specified for additional test points.

The score awarded to each equal width area is the sum of score of all quarters of the equal width area.

2.2.1.2.2 Manufacturer has not provided component as per requirement

Divide headform test zone into 12 equal width areas. C-NCAP Test Evaluation Department selects 6 points potentially causing large injury to pedestrian for test, each equal width area should not contain exceed 1 test point. Select 1 test point for two equal width areas of symmetrical position. Obtain score of each test point as per the determination condition of Table 5 in accordance with test result. The score awarded to the equal width area where test point is located equals to score of the test point multiplied by 4, and equal width area without test point is awarded with score of its symmetrical equal width area.

2.2.2 Scoring of legform test zone

The maximum available score for legform test zone is 3 points and the minimum score is 0 point. Legform test zone is divided into several grid points, the maximum awarded score for each grid point is 1.000 and the minimum awarded score is 0.000. Sum of score of all grid points obtained in test is divided by maximum awarded score of these grid points to obtain score percentage of legform test zone. The percentage is multiplied by total score 3 of legform test zone to obtain the final score of legform test zone, and the score is rounded to 3 decimal places.

Legform test zone is divided into several grid points, select one grid point from every

other grid points starting from L0 or L1. C-NCAP Test Evaluation Department will select program potentially causing large injury to pedestrian for test. Calculate the awarded score as per test results. Grid points that have not been tested will be awarded with the lowest score of the adjacent grid points. Vehicle is deemed as bilateral symmetry by default, grid point of the side not tested will be awarded with score of the symmetrical grid point of the tested side.

If vehicle manufacturer deems that grid points not tested cannot get accurate evaluation or symmetry should not be applied to a certain grid point, manufacturer may propose to add test for the point, and the additional test points should not exceed 3 and should be proposed before start of test.

If manufacturer has not provided components such as front bumper as per the purchase requirements of C-NCAP, then grid points that have not been tested will be awarded score of adjacent test points.

2.2.2.1 Scoring of lower legform test

The maximum score for each grid point in lower legform test is 1.000, which is generated through measurement of relevant indexes, its evaluation indexes include tibia bending moments T1, T2, T3 and T4, and knee ligament MCL, ACL and PCL elongation. In which, the maximum awarded score for tibia bending moment is 0.500, and scoring is based on the worst performing of the four bending moments; the maximum awarded score for knee ligament elongation is 0.500, and scoring is performed under the precondition that values of both ACL and PCL are less than limit (10mm) based upon MCL value. If value ACL or PCL is larger than or equivalent to limit (10mm), then 0 point is awarded to knee ligament elongation.

During scoring, higher performance limit and lower performance limit are adopted for calculation. The lower performance limit and higher performance limit respectively correspond to score of 0.000 and 0.500, where a measurement value falls between the two limits, the score is calculated by linear interpolation, and is rounded to 3 decimal places.

Higher performance limit:	Tibia bending moment	282Nm
	MCL elongation	19mm
Lower performance limit:	Tibia bending moment	340Nm
	MCL elongation	22mm

2.2.2.2 Scoring of upper legform test

The maximum score for each grid point in upper legform test is 1.000, which is generated through measurement of relevant indexes, its evaluation indexes include three bending moments of top, middle and bottom and resultant force of top force and bottom force, and evaluation is based on the worst results of all indexes; in combination with higher performance limit and lower performance limit, the score of grid point is calculated by linear interpolation, and is rounded to 3 decimal places.

Higher performance limit:	Bending moment	285Nm
	Resultant force	5kN
Lower performance limit:	Bending moment	350N
	Resultant force	6kN

3 Active safety

3.1 Test items

3.1.1 Electronic stability control (ESC) system

For test vehicle equipped with ESC system, determine whether the ESC system on vehicle meets the required performance through examination of performance test report that is provided by vehicle manufacturer and issued by third party inspection institution with qualification regarding compliance of the vehicle model with relevant requirements.

3.1.2 Autonomous emergency braking system (AEB)

3.1.2.1 Autonomous emergency braking system for car-to-car rear collision (AEB CCR)

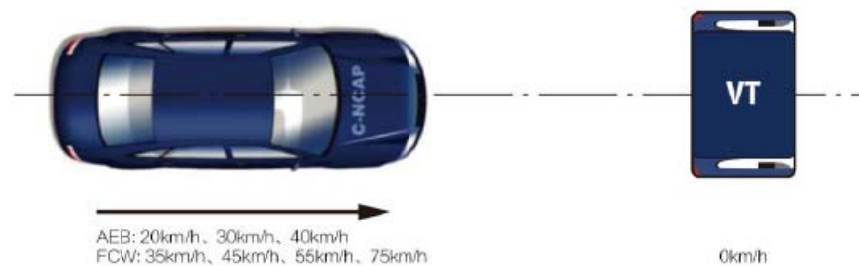

Figure 13a): CCRs car-to-car rear stationary test scenario

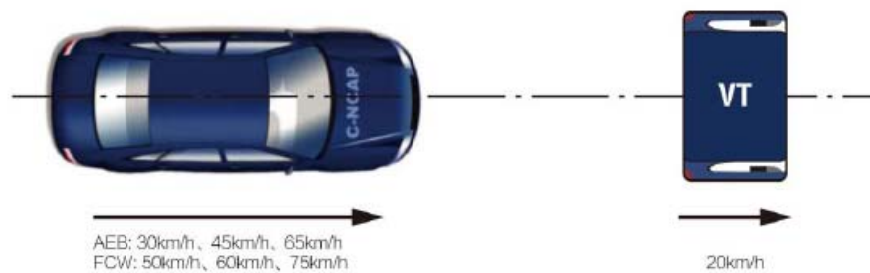

Figure 13b): CCRm car-to-car rear moving test scenario

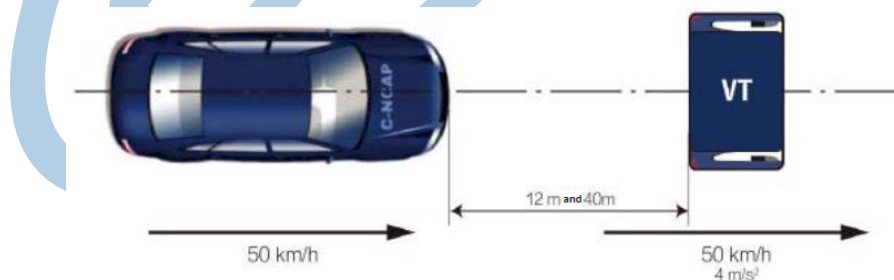

Figure 13c): CCRb car-to-car rear braking test scenario

AEB CCR system is subject to three parts of evaluation. Part 1: AEB function and FCW function test, including three test scenarios: CCRs, CCRm and CCRb, as shown in Figures 13a), 13b) and 13c) and Table 7; part 2: False reaction test: adjacent lane vehicle braking test and iron plate test; part 3: human machine interface (HMI) part. See summary of part 2 and part 3 as per Table 8.

Table 7 AEB function and FCW function test items

Test items	CCRs (car-to-car rear stationary)		CCRm (car-to-car moving)		CCRb (car-to-car braking)	
	AEB	FCW	AEB	FCW	AEB	FCW
Vehicle speed	20km/h	35km/h	30km/h	50km/h	50km/h	50km/h
	30km/h	45km/h	45km/h	60km/h	(12m, 4m/s ²)	(12m, 4m/s ²)

	40km/h	55km/h	65km/h	75km/h	50km/h (40m, 4m/s ²)	50km/h (40m, 4m/s ²)
		75km/h				

Table 8 HMI (Human Machine Interface) and false reaction

Misuse	Items	Speed
	Adjacent lane vehicle braking test	40km/h
	Iron plate test	40km/h, 72km/h
HMI	De-activation requirement	
	Supplementary warning for the FCW system	
	Reversible pre-tensioning of the belt in the pre-crash phase	

3.1.2.2 Autonomous emergency braking system for pedestrian (AEB VRU_Ped)

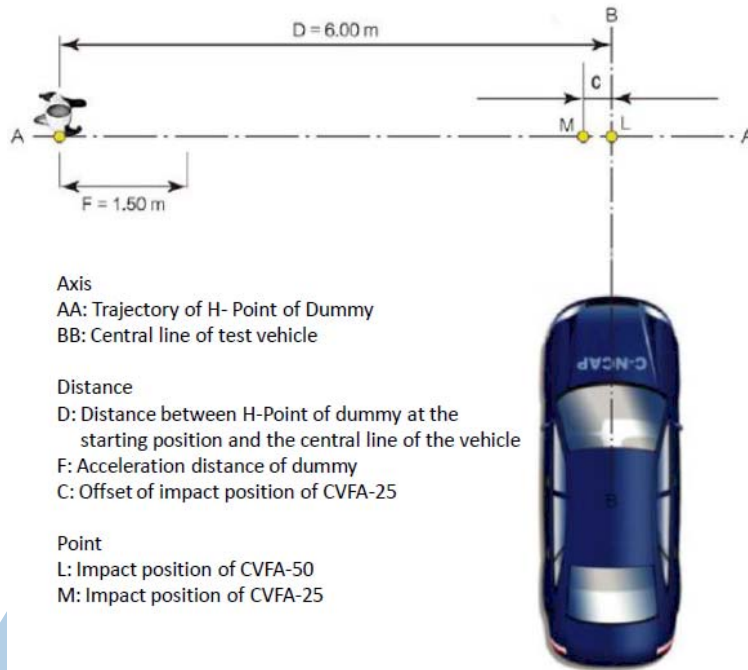

Figure 14 CVFA-50, CVFA-25 (farside) pedestrian test scenario

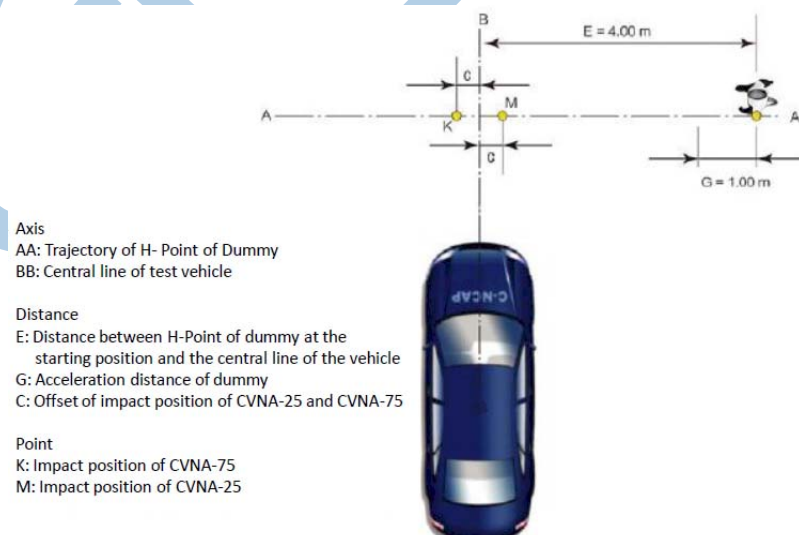

Figure 15 CVNA-25, CVNA-75 (nearside) pedestrian test scenario

AEB VRU_Ped system is subject to two parts of evaluation. Part 1: AEB system function test, including four test scenarios: CVFA-25, CVFA-50, CVNA-25 and CVNA-75; part 2: HMI and other requirements. Table 9 is a summary of AEB VRU_Ped system test items.

Table 9 AEB VRU_Ped system test items

AEB function test items					HMI and other requirements
Vehicle speed	Pedestrian speed				
		CVFA-50	CVFA-25	CVNA-25	CVNA-75
20km/h	6.5km/h	6.5km/h	5km/h	5km/h	De-activation requirement Supplementary warning for the FCW system
30km/h					
40km/h					
50km/h					
60km/h					

Note: CVFA-50 (Car-to-VRU Farside Adult): a vehicle impacts an adult pedestrian crossing from the farside and the impact position is at point “L” shown in Figure 14 when no braking action is applied. Impact position of CVFA-25 is at point “M” as shown in Figure 14.

CVNA-25 (Car-to-VRU Nearside Adult): a vehicle impacts an adult pedestrian crossing from the nearside and the impact position is at point “M” as shown in Figure 15 when no braking action is applied. Impact position of CVNA-75 is at point “K” as shown in Figure 15.

3.2 Performance and scoring method

The total score for active safety part is 15 points, in which, AEB system accounts for 11 points and ESC system accounts for 4 points.

3.2.1 Examination and scoring of electronic stability control system (ESC)

For vehicle equipped with electronic stability control system (ESC), vehicle manufacturer should provide performance test report regarding compliance of the vehicle model with relevant requirements of GB/T 30677-2014 “Performance Requirements and Testing Methods for Electronic Stability Control System (ESC) for Light Vehicles” issued by third party inspection institution with qualification, and submit description document for conformity of C-NCAP sample vehicle to ESC test report sample vehicle, in which parameters comparison Table shown in attachment 8 must be included. 4 points can be awarded after the submitted performance test report, description document for conformity and C-NCAP sample vehicle pass examination by C-NCAP Administration Center.

The performance test report should at least include the following contents:

- a) Compliance with ESC function requirements of standard;
- b) Test data of slow increase of turning angle of steering wheel;
- c) Test data of sine with dwell;
- d) Photo of test vehicle installed with test equipment and testing of vehicle in test track / field / ground;
- e) Parameters directly related to ESC performance, for example: wheelbase, wheelspan, tyre model, Gross Vehicle Mass/ Gross Weight, position of center of mass, suspension structures and main structure parameters.

Note: Performance test report can be based on GTR No.8 “Electronic Stability Control Systems” or FMVSS 126 “Electronic Stability Control Systems Testing” or ECE R13H Annex9 “Electronic Stability Control Systems”, but should not be in violation of relevant requirements in GB/T 30677-2014.

3.2.2 Autonomous emergency braking system (AEB) test scoring

The total score for this test is 11 points, in which, AEB CCR test accounts for 8 points and AEB VRU_Ped test accounts for 3 points.

3.2.2.1 Autonomous emergency braking system for car-to-car rear collision (AEB CCR)

3.2.2.1.1 AEB CCR system speed weighting, scenario weighting and item weighting

Test speeds weighting, scenario weighting and item weighting of AEB CCR system evaluation are shown in the following Table 10.

Table 10 AEB CCR system test items and weighting

Test items	Item weighting	Test scenario	Scenario weighting	Speed	Speed weighting
AEB function	3	CCRs	1	20km/h	1
				30km/h	1
				40km/h	3
		CCRm	2	30km/h	1
				45km/h	1
				65km/h	3
CCRb	1	50km/h, 12m, 4m/s ²	1		
		50km/h, 40m, 4m/s ²	1		
FCW function	2	CCRs	1	35km/h	1
				45km/h	2
				55km/h	2
				75km/h	1
		CCRm	2	50km/h	1
				60km/h	3
				75km/h	3
		CCRb	1	50km/h, 12m, 4m/s ²	1
				50km/h, 40m, 4m/s ²	1
HMI and False reaction	1	HMI	4	De-activation requirement	2
				Supplementary warning for the FCW system	1
				Reversible pre-tensioning of the belt in the pre-crash phase	1
		False reaction	6	Adjacent lane vehicle braking test	3
				Iron plate test	3

3.2.2.1.2 Calculation method of score for all test speed points of AEB CCR system

3.2.2.1.2.1 For the AEB function and FCW function tests, scores are awarded based on the relative speed reduction achieved at every test speed. For test where collision is completely avoided, full score is awarded for the test speed; for test where there is no full avoidance of collision, a linear interpolation is applied to calculate the score of every single test speed, and the score is rounded to 3 decimal places in calculation.

The calculation method is as follows:

$$\text{Scoring rate at test points} = \frac{V_{rel, test} - V_{rel, impact}}{V_{rel, test}}$$

In which: $V_{rel, test}$: Relative speed of VUT (vehicle under test) and VT (vehicle target) at start of test (CCRB: $V_{rel, test}$ is initial speed of VUT);

$V_{rel, impact}$: When VUT impacts VT, the relative speed between them, deduct VT speed from VUT speed at the moment of impact.

3.2.2.1.2.2 If the vehicle speed reduction achieved by the system at a certain test speed <5km/h or V_{impact} (the relative speed when Vut impacts VT) >50km/h, stop the test in the scenario.

3.2.2.1.2.3 T_{FCW} (TTC at the moment of FCW warning alarm) is required to be <4s for all test speed of FCW function, for test with $T_{FCW} \geq 4s$, no points are scored.

3.2.2.1.3 HMI scoring method

Prerequisite for HMI scoring: the AEB and/or FCW function needs to be default ON at the start of every journey and the warning of the FCW system (if applicable) needs to be loud and clear.

When the above prerequisite for scoring is met, three scoring items of HMI are as follows:

- a) De-activation requirement: (2 points)

De-activation of the AEB function and FCW function should not be possible with a single operation on a single button.

- b) Supplementary warning for the FCW system: (1 point)

In addition to the required audiovisual warning, a more sophisticated warning like head-up display, belt jerk, brake jerk or any other haptic feedback is awarded.

Note: This item is not applicable to AEB only systems.

- c) Reversible pre-tensioning of the belt in the pre-crash phase: (1 point)

When the system detects that vehicle is under potential collision hazard condition, safety belt features active pre-tensioning function prior to collision, and structure theory needs to ensure its repeated use.

3.2.2.1.4 False reaction scoring method

False reaction contains two test scenarios:

- a) Adjacent lane vehicle braking test: (3 points)

Test consists of VUT, MLV (Moving Lead Vehicle) and DLV (vehicle decelerating on adjacent lane). VUT, MLV and DLV move at constant speed of 40km/h, then DLV applies braking at deceleration of $(3\pm 0.3) \text{ m/s}^2$, AEB function and FCW function of VUT should not be triggered, 3 points are awarded for passing of test.

- b) Iron plate test: (3 points)

Drive VUT respectively at constant speeds of 40km/h and 72km/h towards steel plate placed on test road. The dimension of steel plate is $2.4\text{m}\times 3.7\text{m}\times 0.025\text{m}$, AEB function of VUT should not be triggered, and FCW should not warn or DBS is not triggered after warn, 3 points are awarded for passing of test.

3.2.2.1.5 AEB CCR system scoring

3.2.2.1.5.1 Firstly, obtain the scoring rate of each test speed in accordance with test results as per 3.2.2.1.2.1 of this Chapter.

3.2.2.1.5.2 In accordance with the scoring rate of each test speed point and the corresponding speed weighting percentage, calculate to obtain the scoring rate of AEB function and FCW function in each scenario.

3.2.2.1.5.3 In accordance with the scoring rate in each scenario and weighting percentage of the corresponding scenario, calculate to obtain the scoring rate of AEB function and FCW function.

3.2.2.1.5.4 Determine all items of HMI and false reaction, so as to obtain the scoring rate of HMI and false reaction.

3.2.2.1.5.5 In accordance with the scoring rate of AEB function, FCW function, HMI and false reaction and the corresponding weighting percentage, calculate to obtain the scoring rate of AEB CCR system.

3.2.2.1.5.6 AEB CCR system score is calculated as per the following formula.

$$\text{AEB CCR system score} = \text{AEB CCR system scoring rate} \times 8.$$

3.2.2.1.6 Scoring method for different combinations of AEB function and FCW function

3.2.2.1.6.1 System combining AEB function and FCW function

Calculate AEB CCR system score as per 3.2.2.1.5.

3.2.2.1.6.2 System featuring AEB function only

All test speed points of AEB and FCW are tested. Test speed point of FCW is in compliance with the test method of AEB, and the scoring method is in compliance with 3.2.2.1.5.

3.2.2.1.6.3 System featuring FCW function only

Test is performed only for FCW part, AEB function part score is zero, and the scoring method is in compliance with 3.2.2.1.5.

3.2.2.2 Pedestrian autonomous emergency braking system (AEB VRU_Ped)

2.2.2.1 AEB VRU_Ped system speed point weighting, scenario weighting and item weighting

Prerequisite for scoring point for AEB VRU_Ped system is:

- AEB VRU_Ped system should be activate (warn or brake) from speed of 10km/h in CVNA-75 scenario.
- The system should be able to detect pedestrians walking at 3km/h and reduce vehicle speed in the CVNA-75 scenario at vehicle speed of 20km/h.
- No point is awarded to AEB VRU_Ped system when only FCW warn function is available.

Evaluation of AEB VRU_Ped system consists of 2 parts: AEB function and HMI function. Table 11 below is a summary of all test speeds, scenario weighting and item weighting.

Table 11 EB VRU_Ped system test items and weighting

Items	Item weighting	Scenario	Scenario weighting	Speed point	Speed weighting
AEB function	5	CVFA-25	1	20km/h	1
				30km/h	2
				40km/h	2
				50km/h	2
				60km/h	1
		CVFA-50	1	20km/h	1
				30km/h	2
				40km/h	2
				50km/h	2
				60km/h	1
		CVNA-25	1	20km/h	1
				30km/h	1
				40km/h	2
				50km/h	2
				60km/h	1
AEB function		CVNA-75	1	20km/h	1
				30km/h	1
				40km/h	2
				50km/h	2
				60km/h	1
HMI	1	De-activation requirement		2	
		Supplementary warning for the FCW system		1	

3.2.2.2.2 Scoring method for AEB VRU_Ped system

For the AEB VRU_Ped system function tests, scoring is based on the relative speed reduction achieved every test speed when $V_{vut}(\text{Speed of VUT}) \leq 40\text{km/h}$. For test where collision is completely avoided, full score is awarded for the test speed point; for test where there is no full avoidance of collision, a linear interpolation is applied to calculate the score for the corresponding single test, and the score is rounded to 3 decimal places in calculation.

Calculation method for $V_{vut} \leq 40\text{km/h}$ is as follows:

$$\text{Scoring rate at test points} = \frac{V_{\text{test}} - V_{\text{impact}}}{V_{\text{test}}}$$

Note: V_{test} is test speed and V_{impact} is the speed at the moment of collision.

For test points of $V_{VUT} > 40\text{km/h}$, full points are awarded when a speed reduction $\geq 20\text{km/h}$ is achieved by AEB function. Zero point is awarded when a speed reduction is $< 20\text{km/h}$, and test in the scenario is stopped.

3.2.2.2.3 HMI scoring method

Prerequisite for HMI scoring: When vehicle is started, AEB and FCW system needs to be default “ON”;

When the prerequisite for scoring mentioned above is met, two scoring items of HMI are as follows:

De-activation requirement: (2 points)

De-activation of the AEB function and FCW function should not be possible with a single operation on a single button.

FCW warn requirements: (1 point)

When $V_{VUT} > 40\text{km/h}$ and potential collision between vehicle and PTA is detected, the system must send loud and clear warning to remind driver. Warning should be sent before TTC is equivalent to 1.2s (inspected at speed of 45km/h in CVNA-75 scenario), so as to leave sufficient time for the driver to react to the warning.

Note: Points are awarded only if the two requirements mentioned above are met at the same time; no point is awarded for system without FCW function.

3.2.2.2.4 AEB VRU_Ped system score calculation step

3.2.2.2.4.1 Firstly, obtain the scoring rate of each test speed point in accordance with test results as per 3.2.2.2.2.

3.2.2.2.4.2 In accordance with the scoring rate of each test speed point and the corresponding speed weighting percentage, calculate to obtain the scoring rate of AEB function in each scenario.

3.2.2.2.4.3 In accordance with the scoring rate in each scenario and the corresponding scenario weighting percentage, calculate to obtain the scoring rate of AEB function.

3.2.2.2.4.4 Determine all items of HMI, so as to obtain the scoring rate of HMI part.

3.2.2.2.4.5 In accordance with the scoring rate of AEB function and HMI part and the corresponding weighting percentage, calculate to obtain the scoring rate of AEB VRU_Ped system.

3.2.2.2.4.6 AEB VRU_Ped system score is calculated as per the following formula:

$$\text{AEB VRU_Ped system score} = \text{AEB VRU_Ped system scoring rate} \times 3.$$

3.2.3 Scoring of active safety

3.2.3.1 Score and scoring rate of active safety part are calculated as per the following formula:

$$\text{Score of active safety part} = (\text{score of AEB CCR} + \text{score of AEB VRU_Ped}) \times \text{configuration factor} + \text{score of ESC}$$

$$\text{Scoring rate of active safety part} = \text{score of active safety part} / 15 \times 100\%$$

3.2.3.2 If test vehicle selected for C-NCAP test is configured with AEB system, then AEB system configuration factor is set as 1; if all vehicle models are configured with AEB system as standard, AEB configuration factor is set as 1.2;

3.2.3.3 If test vehicle selected for C-NCAP test is not configured with AEB system, and other configurations of the vehicle model are equipped with AEB system, then enterprise may declare all configurations of the vehicle model and the corresponding the actual sales data, and propose recommendations on configuration of vehicle model subject to AEB system test, and provide one unit of vehicle with the configuration actually delivered from factory to C-NCAP Administration Center. C-NCAP Administration Center should verify configuration factor in accordance with AEB performance and configuration situations of the AEB test vehicle.

3.2.3.4 See relation between configuration rate and configuration factor of AEB system as per Table 12.

Table 12 Configuration factor of AEB system

Conditions	Configuration rate	Configuration factor
All vehicle models are configured AEB system as standard	/	1.2
When AEB system is configured on C-NCAP test vehicle	/	1
When AEB system is not configured on C-NCAP test vehicle	A≥25%	1
	25%.A≥15%	0.8
	15%>A≥5%	0.6
	A<5%	0
A -- The ratio of total sales of all configurations equipped with system to total sales of the vehicle model.		

3.2.4 Example of score calculation of active safety

Assume that a vehicle features AEB CCR, AEB VRU_Ped and ESC function at the same time, and vehicle sampled by C-NCAP is not configured with AEB CCR and AEB VRU_Ped function, AEB configuration factor is 0.6, test results are as follows:

3.2.4.1 Example of test results of AEB CCR system

a) Assumed test results of AEB function

Scenario	V _{test}	V _{rel-test}	Weighting	V _{impact}	V _{rel-impact}	Scoring rate
CCRs	20km/h	20km/h	1	0km/h	0km/h	100.0%
	30km/h	30km/h	1	0km/h	0km/h	100.0%
	40km/h	40km/h	3	20km/h	20km/h	50.0%
CCRm	30km/h	10km/h	1	0km/h	0km/h	100.0%
	45km/h	25km/h	1	30km/h	10km/h	60.0%
	65km/h	45km/h	3	40km/h	20km/h	55.6%
CCRb	12m, 4m/s ²	50km/h	1	0km/h	0km/h	100.0%
	40m, 4m/s ²	50km/h	1	25km/h	25km/h	50.0%

Scoring rate in the CCRs scenario = $(100.0\% \times 1 + 100.0\% \times 1 + 50.0\% \times 3) / (1 + 1 + 3) \times 100\% = 70.0\%$

Scoring rate in the CCRm scenario = $(100.0\% \times 1 + 60.0\% \times 1 + 55.6\% \times 3) / (1 + 1 + 3) \times 100\% = 65.4\%$

Scoring rate in the CCRb scenario = $(100.0\% \times 1 + 50.0\% \times 1) / (1 + 1) \times 100\% = 75.00\%$

In accordance with CCRs:CCRm:CCRb=1:2:1

Scoring rate of AEB function = $(\text{scoring rate in the CCRs} \times 1 + \text{scoring rate in the CCRm} \times 2 + \text{scoring rate in the CCRb} \times 1) / 4 \times 100\% = 68.9\%$

b) Assumed test results of FCW function

The score calculation method of FCW function is identical with that of AEB function. It is assumed that the scoring rate of FCW function is 60.00%.

c) Test results of HMI and misuse

Prerequisite for scoring point for HMI is met.

Items	Evaluation items	Evaluation items weighting	Score
HMI and misuse	De-activation requirement	2	2.000
	FCW assistance alarm requirement	1	0.000
	Active safety belt prewarning function	1	0.000
	Adjacent lane vehicle braking test	3	3.000
	Iron plate test	3	3.000

Scoring rate of HMI and misuse = $(2.000 + 3.000 + 3.000) / (2 + 1 + 1 + 3 + 3) \times 100\% = 80.0\%$

d) Score value of AEB CCR system

Weighting of AEB function, FCW function, HMI and misuse is 3:2:1.

Final evaluation AEB CCR system scoring rate is:

$(69.0\% \times 3 + 60.0\% \times 2 + 80.0\% \times 1) / 6 \times 100\% = 67.8\%$

Final score of AEB CCR system is: $67.80\% \times 8$ (full score value) = 5.424 points

3.2.4.2 Example of test results of AEB VRU_Ped system

a) Test results

Speed at test point	Weighting	V _{impact}	Score
20km/h	1	0km/h	100.0%
30km/h	2	0km/h	100.0%
40km/h	2	20km/h	50.0%
50km/h	2	30km/h	100.0%
60km/h	1	45km/h	0.0%

The scoring rate in CVFA-25 scenario is:

$$(100.0\% \times 1 + 100.0\% \times 2 + 50.0\% \times 2 + 100.0\% \times 2 + 0.0\% \times 1) / 8 \times 100\% = 75.0\%$$

b) Scoring rate of other scenarios is assumed as follows:

Scoring rate in the CVFA-25 scenario: 50.0%

Scoring rate in the CVNA-25 scenario: 76.7%

Scoring rate in the CVNA-75 scenario: 100.0%

$$\text{Scoring rate of AEB function} = (75.0\% + 50.0\% + 76.7\% + 100.0\%) / 4 \times 100.0\% = 75.4\%$$

c) HMI

Prerequisite for scoring point is met.

Items	Evaluation items	Evaluation items weighting	Score
HMI	De-activation requirement	2	2.000
	FCW alarm requirements	1	0.000

$$\text{Scoring rate of HMI} = (2.000 + 0) / (2 + 1) \times 100\% = 66.7\%$$

d) Scoring rate of AEB VRU_Ped system = $(75.4\% \times 5 + 66.7\% \times 1) / (5 + 1) \times 100\% = 74.0\%$

$$\text{Score of AEB VRU_Ped system} = 74.0\% \times 3 = 2.220$$

3.2.4.3 Example of ESC test results

Assume that test vehicle features ESC function, and the submitted test report passed examination, 4 points are awarded to ESC.

3.2.4.4 Score for active safety

Score for active safety part = (score of AEB CCR + score of AEB VRU_Ped) × AEB configuration factor + score of ESC

$$= (5.424 + 2.220) \times 0.6 + 4$$

$$= 8.586$$

$$\text{Scoring rate of active safety part} = 8.586 / 15 \times 100\% = 57.2\%$$

4 Scoring and star rating

C-NCAP performs star rating as per comprehensive scoring rate of three parts of occupant protection, pedestrian protection and active safety. The score is respectively calculated through test items for three parts of occupant protection, pedestrian protection and active safety, see full score of all items and score value of score adding items as per Table 13.

Table 13 Score value for each part of C-NCAP

Parts	Categories of items	Items	Score value		Total score of each part
			Front row	Back row	
Occupant protection ^{a)}	Test item	100% frontal collision	16	4	70
		40% offset collision	16	4	

		Lateral collision	16	4	
		Whiplash	5		
	Score adding item	Lateral curtain airbag	3		
		Safety belt reminding ^{b)}	2		
Pedestrian protection	Test item	Headform	12		15
		Legform	3		
Active safety	Examination item	ESC	4		15 ^{c)}
		Test item	AEB CCR	8	
	AEB VRU_Ped		3		
Note:					
a) For vehicle with single row of seats, the back row score is not counted, and the full score for occupant protection is 57 points.					
b) 1 point is awarded if safety belt reminder at occupant side of front row meets requirements; and 1 point is awarded if safety belt reminder at all seats of 2 nd row meet requirements.					
c) The maximum available score for active safety part is 15 points, even if total score is exceeded during calculation due to different AEB configuration factors, it is still counted as 15 points.					

Divide the actual score of each of three parts of occupant protection, pedestrian protection and active safety by the total score of relevant parts to obtain the respective scoring rates for the three parts, then multiply the respective scoring rates by weight factor of the three parts (occupant protection: 0.7; pedestrian protection: 0.15; active safety: 0.15), then sum up to obtain the comprehensive scoring rate. In accordance with the final comprehensive scoring rate, perform star rating of test vehicle as per the following star rating criteria.

Star level	Comprehensive scoring rate
5+(★★★★★☆)	≥90%
5(★★★★★)	≥82%and<90%
4(★★★★)	≥72%and<82%
3(★★★)	≥60%and<72%
2(★★)	≥45%and<60%
1(★)	<45%

On the basis of consideration of vehicle safety performance balance, besides compliance with the above mentioned requirements on comprehensive scoring rate, it is also required to meet the minimum scoring rate requirements for three parts of occupant protection, pedestrian protection and active safety (see Table 14) in order to obtain final star rating. In case of any fail item, determine the final star rating as per the minimum star rating criteria reached by the scoring rate.

Table 14 Requirements on the minimum scoring rate for each part ofC-NCAP

Star levels	Minimum scoring rate for each part				
	Occupant protection	Pedestrian protection	Active safety		
			2018	2019	2020
5+(★★★★★☆)	≥95%	≥75%	≥50%	≥55%	≥72%
5(★★★★★)	≥85%	≥65%	≥26%	≥38%	≥55%
4(★★★★)	≥75%	≥50%	≥26%	≥26%	≥26%
3(★★★)	≥65%	≥40%	/	/	/
2(★★)	≥55%	≥20%	/	/	/
1(★)	<55%	<20%	/	/	/

Furthermore, vehicle should be degraded under following situations:

- In impact test, if there is fire phenomenon (naked flame observed) (in engine compartment) within 3min after end of any impact test, the vehicle should be degraded by one star level.
- With regard to a five-star vehicle, for the three impact tests (i.e., frontal 100% overlapped impact test against rigid barrier, frontal 40% overlapped impact test against deformable barrier, and lateral impact test against deformable mobile barrier), no particular area of the front-row dummy may be awarded zero point. Otherwise, it will be downgraded as a four-star vehicle. For the frontal impact test against the rigid barrier with 100% overlapping and the frontal impact test against the deformable barrier with 40% overlapping, particular areas include head, neck and thorax. For the side impact test against the mobile deformable barrier, particular areas include head, thorax, abdomen and pelvis.

c) For vehicles of 4 stars and higher star levels, ESC system should be configured.

For battery electric vehicle/hybrid electric vehicle (EV/HEV), besides the above mentioned rules on scoring, it is also required to meet electric safety requirements in this rule, electric safety evaluation results are classified as safe/unsafe only. For vehicles that are in compliance with electric safety requirements, besides the star rating results, electric safety marking  will be adopted for indication; for vehicles that are not in compliance with electric safety requirements, instead of star rating, only single item scoring results of each part and items that are not in compliance with electric safety will be publicized.



Chapter IV Impact Test and Whiplash Test Procedures

1 Procedures for frontal impact test against rigid barrier with 100% overlapping

1.1 Vehicle preparation

1.1.1 Checking and confirming vehicle(s) upon arrival

When the vehicle to be tested arrives at the laboratory, the C-NCAP logo and the vehicle's unique identification - the test number and the laboratory information shall be attached to the vehicle. And measure and record the mass of the vehicle and its front and rear axle loads. Check and confirm the appearance, configuration and basic parameters of the vehicle (see Appendix 3).

1.1.2 Common fuel vehicle

1.1.2.1 Measurement of vehicle kerb mass

1.1.2.1.1 Drain the fuel from the tank and then run the engine until it has run out of fuel.

1.1.2.1.2 Calculate the mass of fuel contained in the fuel tank at its rated capacity, using a density for petrol of 0.74g/ml or 0.84g/ml for diesel fuel. The fuel tank shall be filled with water to mass equal to 90 percent of the mass of a fuel of the fuel tank at its rated capacity.

1.1.2.1.3 Check and adjust tyre pressure according to the manufacturer's instructions for half load. Check and top up the levels of all other fluids (e.g., engine oil, transmission fluid, brake fluid, washing fluid, antifreeze, etc.) to their maximum levels. Confirm the spare tyre and driver tool are on-board. Nothing else shall be in the vehicle.

1.1.2.1.4 Measure and record the height of the intersection point between the transverse plan passing through the centers of the 4 wheels and the upper edge of the wheel guard plate.

1.1.2.1.5 Measure and record the mass of the vehicle and its front and rear axle loads. The mass of the vehicle is the kerb mass of the complete vehicle.

1.1.2.2 Vehicle preparation and installation of test equipments

1.1.2.2.1 Drain the engine oil, transmission fluid, brake fluid, washing fluid, antifreeze, power assisted fluid, etc. In this case, the mass of the liquids shall be offsets. Drain the fluids in the air conditioning system.

1.1.2.2.2 Remove the luggage area carpeting, driver tool and spare tyre from the vehicle (ensure that spare tyre will not affect the crash performance of the vehicle).

1.1.2.2.3 Fix the on-board data acquisition equipment. Also install one-way accelerometers at the base of the 'B' pillars on the left and right sides of the vehicle.

1.1.2.2.4 Measure the mass of the vehicle and its front and rear axle loads. Compare them with those determined in Paragraph 1.1.2.5. The load of each axle shall not differ by more than 5 percent, each variation not exceeding 20kg, and the mass of the vehicle by more than 25kg. Any component(s) not liable to affect the crash performance of the vehicle may be added or removed and the mass of the water in the fuel tank may be adjusted to help achieve the desired weights. Record the final mass of the vehicle and its final front and rear axle loads.

1.1.2.2.5 Upon completion of the procedure described in Paragraph 1.7.2, measure and record the mass of the vehicle and its front and rear axle loads. The mass of the vehicle determined herein is the test mass (including dummies and all instrumentation). Measure and record the height of the intersection point between the transverse plan passing through the center of each of the four wheels and the upper edge of the wheel guard.

1.1.3 Pure electric vehicle / hybrid electric vehicle (EV / HEV)

1.1.3.1 Report and registration of basic information of vehicle

Manufacturer should submit information related to high voltage system and its assembly layout and/or position to C-NCAP Administration Center, including:

- 1.1.3.1.1 Layout diagram or photo of high voltage system and its assembly, and layout position indicating rechargeable energy storage system (REESS).
- 1.1.3.1.2 Explanatory drawing and written record material related to fixture method of REESS.
- 1.1.3.1.3 Material description related to battery type of REESS, battery capacity, electrolyte composition and its total volume, etc.
- 1.1.3.1.4 For vehicle featuring high voltage automatic disconnection device, if manufacturer determines to perform verification test for validity of device, then it is necessary to provide the position of automatic disconnection device of vehicle, and briefly describe its working theory or working method.

1.1.3.2 Vehicle charging

Before test, it is necessary to charge traction battery. Impact test of battery electric vehicle and plug-in hybrid electric vehicle should be performed within 24h after end of charge of vehicle.

- 1.1.3.2.1 For plug-in battery electric vehicle and hybrid electric vehicle, it is allowed to charge traction battery to the maximum state of charge as per the requirement of manufacturer.
- 1.1.3.2.2 For plug-in battery electric vehicle and hybrid electric vehicle, perform full charge of traction battery as per clause 5.1 of GB/T 18385-2005 if manufacturer has no requirement.
- 1.1.3.2.3 For non-plug-in hybrid electric vehicle, prepare test as per the normal operating conditions of vehicle.

1.1.3.3 Measurement of kerb mass of vehicle

If vehicle is equipped with traction battery liquid cooling system, it is necessary to drain coolant after completion of charging, and replace with equivalent mass of liquid of color different from electrolyte of traction battery. For hybrid electric vehicle, it is also necessary to perform fuel treatment as per 1.1.2.1.1-1.1.2.1.2. Then proceed with measurement of kerb mass of vehicle as per 1.1.2.1.3-1.1.2.1.5.

1.1.3.4 Measurement of reference mass of vehicle

Perform measurement of reference mass of vehicle as per 1.1.2.2.

1.1.3.5 Preparation of vehicle and installation of test equipments

Drain fluids such as brake fluid, detergent, anti-freeze fluid and steering assistance fluid, and compensate the mass of the discharged fluids. Drain the liquid in air conditioning system. Proceed with preparation of vehicle and installation of test equipments as per 1.1.2.2.2-1.1.2.2.5.

1.1.3.6 Determination of measurement point of electrical safety

- 1.1.3.6.1 Determine the measurement point of insulation resistance at traction battery side, and measure the voltage of positive/negative poles of traction battery side and the voltage between positive/negative poles of traction battery and electric chassis.
- 1.1.3.6.2 Determine the measurement point of insulation resistance at power system load side, and measure the voltage of positive/negative poles of load side and the voltage between positive/negative poles at load side and electric chassis.
- 1.1.3.6.3 Mark at the fixing position of REESS assembly of test vehicle for measurement of displacement and separation of relevant assemblies after impact.

1.2 Measurement of vehicle deformation

For vehicle deformation measurement, a mobile 3D coordinates measuring machine (the software shall present the coordinate conversion function: an appropriate coordinate system could be automatically generated based on the inputs of the coordinate values of several points) shall be used. The machine requires a coordinate system to be set up relative to a particular plane, with its axes being in the same directions of those of the vehicle coordinate system. During the testing, some structure at the rear of the vehicle can be used as a reference point for measurement. During the measurement, the vehicle shall be in a state as described in Paragraph 1.1.2.2.4.

1.2.1 Before test

- 1.2.1.1 The steering wheel, if adjustable, shall be placed in the midway between the limits of its range(s) of adjustment in any direction.
- 1.2.1.2 The ignition switch shall be placed at the “off” position and the battery shall be disconnected.
- 1.2.1.3 Remove the components equipped at the center of the steering wheel or, if fitted, the airbag to expose the end of the steering column. When doing this, carefully mark the connection lines to the airbag which will need to be remade on re-assembly. The removal of the airbag or the components equipped at the center of the steering wheel shall follow the instruction recommended by vehicle manufacturer.
- 1.2.1.4 Mark the center of the top of the steering-column.
- 1.2.1.5 Set up the coordinate system of vehicle bodywork, by applying either of the following procedures.
 - 1.2.1.5.1 Provided, for the non-deformation locations at the rear end of the vehicle (left, right, and middle), manufacturer could furnish the coordinate values of 8 characteristic points (spatially scattered to the maximum practicable extent, and convenient for measurement) under the designed bodywork coordinate system for the vehicle, record them, based on which the designed bodywork coordinate system is subsequently set up through the use of software.
 - 1.2.1.5.2 Provided manufacturer could not furnish the 8 characteristic points described in Paragraph 1.2.1.5.1, set up the bodywork coordinate system as follows: Adjust the vehicle until the horizontal level is attained; mark the position of at least 8 datum points (spatially scattered to the maximum practicable extent) on the rear end of the vehicle (left, right and middle), which are not expected to deform in the test. Among them, 1 point serves as the original point of the coordinate, and two points are taken to establish the x or y axis, which is in parallel with the corresponding axis of the bodywork coordinate system. Where such two points are not available on the vehicle body, then two points that are basically in parallel with the corresponding axis of the vehicle coordinate system are to be given by the manufacturer. Establish a ‘z’ plane on the plane ground on which the vehicle stays, and horizontally moves it through the original point of the coordinate. Record the coordinate values of 8 characteristic points.
- 1.2.1.6 Measure and record the coordinate located in the marked centre of the top of the steering-column.
- 1.2.1.7 Mark, measure and record the B-pillars on the driver and occupant sides:
 - I At a distance of 100mm above the sill;
 - II At a distance of 100mm beneath the lowest level of the side window frames on both sides.All points should be as close as possible to the rubber sealing strip around the door aperture.
- 1.2.1.8 Refix the component in the center of the steering wheel, and check all bolts are securely fastened.

1.2.1.9 Connect the battery, check whether the circuit is functional or not. Ensure that airbags are in a normal working condition.

1.2.2 After test

1.2.2.1 Remove the dummies from the occupant compartment.

1.2.2.2 Remove the center of the steering wheel.

1.2.2.3 Measure the 8 characteristic points measured (datum points) prior to the test.

1.2.2.4 Set up the bodywork coordinate system. With the software, input the pre-test coordinate values of any 6 points among the 8 characteristic points (datum points), so as to set up, via the software, the bodywork coordinate system based on the coordinate values of these 6 points. In the newly-established coordinate system, compare the coordinate values of such 6 points with their pre-test counterparts; in case of low consistency, randomly select 6 out of the 8 characteristic points (datum points) to re-establish the bodywork coordinate system, and conduct comparison again. In case the consistency is low either, correct the measurement values in accordance with the procedures shown in Paragraph 1.2.3.

1.2.2.5 Measure and record the coordinate located in the marked centre of the top of the steering-column.

1.2.3 Modification

1.2.3.1 After the test, measure and record the marks on the driver and occupant-side B-pillar.

1.2.3.2 Compare the changes in positions of related B-pillar points above the z axis before and after the test.

1.2.3.3 Find the angle θ that best satisfies the following equation: $z = -x/\sin\theta + z1/\cos\theta$ for the B-pillar sill point (where z = pre-impact vertical measurement, and $x1, z1$ = post-impact longitudinal and vertical measurement), get θ value.

1.2.3.4 Transform the post impact longitudinal and vertical measurements (x, z) using the following equations:

$$\begin{bmatrix} X \\ Z \end{bmatrix} = \begin{bmatrix} \cos \theta & \sin \theta \\ -\sin \theta & \cos \theta \end{bmatrix} \begin{bmatrix} x1 \\ z1 \end{bmatrix}$$

Note: X, Z = the corrected coordinate values, $x1, z1$ = the actual values measured after the impact.

1.2.4 Results

The following measurement results may be obtained based on the pre-impact measurements and post impact measurements (or the post impact measurements modified).

1.2.4.1 The longitudinal and vertical displacements of the steering-column.

1.3 Occupant compartment adjustments

1.3.1 Front seat adjustments

1.3.1.1 Front seats adjustable longitudinally shall be placed in the middle position of travel or in the nearest backward locking position. Check and confirm the seat sliding system is in a completely locked position.

1.3.1.2 Front seats independently adjustable for height shall be placed at the height position defined by the manufacturer or the lowest position.

1.3.1.3 Seat cushions adjustable for inclination shall be adjusted to the position defined by the manufacturer or the middle position.

1.3.1.4 If adjustable, the seat-backs shall be adjusted so that the resulting inclination of the torso of HPM machine is as close as possible to that recommended by the manufacturer for

normal use or to 25° towards the rear from the vertical.

- 1.3.1.5 Where adjustable, the lumbar support shall be placed at the position defined by the manufacturer or the completely retracted position.
- 1.3.1.6 Head restraints adjustable for height shall be in their uppermost position.
- 1.3.1.7 Head restraints adjustable for inclination shall be adjusted to the position defined by the manufacturer or the middle position.
- 1.3.1.8 Arm-rests shall be in the lowered position, unless this is prevented by the position of the dummies in the vehicles.
- 1.3.1.9 Other adjustment mechanisms shall be set to the manufacturer's design position.

1.3.2 Adjustment of the second row of seats

- 1.3.2.1 The second-row seat adjustable longitudinally shall be placed in the middle position of travel or in the nearest rearward locking position. Check and confirm the seat sliding system is in a completely locked position.
- 1.3.2.2 For a second-row seat allowing vertical adjustment, seat height shall be set to the manufacturer's design position or the lowest position.
- 1.3.2.3 For a second-row seat with adjustable seat back, the seat back shall be adjusted to the manufacturer's design position or the position inclining backwards by 23° from the vertical plane.
- 1.3.2.4 Lumbar support, if any, for second-row seat shall be adjusted to the manufacturer's design position or the fully retracted position.
- 1.3.2.5 Head restraints of rear seats placed with female dummy shall be adjusted to the lowest lock position. For a second-row seat fitted with child restraint system, the head rest shall be adjusted to a proper position suitable for the installation; if interfering with the installation of the anticipated child restraint system, such head restraint may be removed.
- 1.3.2.6 Rear seats adjustable for orientation shall be adjusted to forward facing.
- 1.3.2.7 Other adjustment mechanisms shall be set to the manufacturer's design position.

1.3.3 Steering wheel adjustments

- 1.3.3.1 The steering wheel adjustable horizontally shall be placed in midway between the limits of its range(s) of adjustment.
- 1.3.3.2 The steering wheel adjustable longitudinally shall be placed in midway between the limits of its range(s) of adjustment.
- 1.3.3.3 The steering wheel shall be left free, with its spokes in the position which according to the manufacturer corresponds to straight-ahead travel of the vehicle.

1.3.4 Adjustment of safety belt anchorages

Where adjustable, safety belt anchorages shall be placed in the position defined by the manufacturer or the middle position, or close to the fixed upper midway.

1.3.5 Gear-change lever

The gear-change lever shall be in the neutral position.

1.3.6 Glazing

The movable glazing of the vehicle shall be in the closed position, meanwhile, the position of the operating handle corresponds to the closed position of the glazing.

1.3.7 Pedals

The pedals shall be in their normal released position.

1.3.8 Sun-visor

The sun-visors shall be in the stowed position.

1.3.9 Rear-view mirror

The interior rear-view mirror shall be in the normal position of use.

1.3.10 Doors and lock

The doors shall be latched but not locked. For vehicles with automatic door lock function, the door should be locked before the test.

1.3.11 Opening roof

If an opening or removable roof is fitted, it shall be in place and in the closed position.

1.3.12 Parking brake

Parking brakes shall be released.

1.4 Dummy preparation and calibration

During the test, two HybridIII 50% male dummies, one HybridIII 5% female dummies, and one Q-series dummy representing a 3-years-old child are to be used. Each dummy will be clothed with formfitting cotton stretch garments with short sleeves and pants; each dummy representing an adult shall be with shoes. Moreover, neck sheath shall be fitted for adult dummy.

1.4.1 Ambient conditions for dummy tests

1.4.1.1 The dummy shall be tested at the temperature of 20°C~22°C and the humidity of 10%~70%.

1.4.1.2 The dummy shall be placed in temperatures specified in Paragraph 1.4.1.1 for at least 5 hours prior to the calibration of the dummy, the adjustment of dummy joints and the impact test.

1.4.2 Adjustment of dummy joints

1.4.2.1 The dummy joints should be adjusted as close as possible to the time of the test and, in any case, not more than 24h before the test.

1.4.2.2 All constant friction joints shall be subject to adjustment. When a force being 1g~2g is applied, the dummy limbs can continue to move.

1.4.3 Calibration of dummies

1.4.3.1 HybridIII 50% male dummies shall be calibrated in accordance with the provisions of CFR 572 Subpart E, Appendix 10 to ECE R94 and SAE 2779; HybridIII 5% female dummies in accordance with the provisions of CFR 572 Subpart O and SAE J2878; the dummy representing a child shall be calibrated in accordance with the user's manual as furnished by the dummy manufacturer.

1.4.3.2 The dummies shall be re-calibrated after every two impact tests. The knee sliding displacement shall be calibrated in accordance with SAE J2876 after every two impact tests and re-calibrated in accordance with SAE J2856 after every eight tests.

1.4.3.3 If an injury criterion reaches or exceeds its low accepted limit as specified in Paragraph 2.1.1.1 of Chapter III, then that part of the dummy shall be re-calibrated.

1.4.3.4 If any part of a dummy is broken in a test then the part shall be replaced.

1.4.3.5 All data concerning the calibration of dummies shall be maintained for future check.

1.5 Preparations of child restraint system

The test could be conducted on the child restraint system required or recommended in

product instruction, but the manufacturer must apply after receiving the test notice and provide the sample within 3 days prior to the test. If the manufacturer doesn't apply or provide the child restraint system applied for in time, the test will be conducted with the type of CRS as designated by the C-NCAP Management Center.

1.6 Instrumentation

All instrumentation shall be calibrated prior to the test. All instrumentation shall be re-calibrated after one year, regardless of their use frequency. Accelerometers shall be subject to normal calibration with vibration sensor calibrators, to ensure the accuracy of test results. The Channel Amplitude Class (CAC) for each transducer shall be chosen to cover the Minimum Amplitude listed in Table 15. In order to ensure the accuracy of the test, CACs which are orders of magnitude greater than the Minimum Amplitude shall not be used. A transducer shall be re-calibrated if it reaches its CAC during any test.

Table 15 Test requirements

Instrumentation	Location	Minimum	Channels	
Driver HybridIII 50% male dummy	Head: Accelerations	Ax, Ay, Az	250g	3
	Neck: Forces and moments	Fx	9kN	3
		My	280Nm	
		Fz	13kN	
	Thorax: Deformation and accelerations	Dchest	90mm	4
		Ax, Ay, Az	150g	
	Upper leg: Compression forces (L/R)	Fz	13kN	2
	Knees: Sliding displacements (L/R)	Dknee	19 mm	2
	Upper tibia: Forces and moments (L/R)	Fz	12kN	6
		Mx, My	400Nm	
Lower tibia: Forces and moments (L/R)	Fz	12kN	6	
	Mx, My	400Nm		
Front occupant HybridIII 50% male dummy	Head: Accelerations	Ax, Ay, Az	250g	3
	Neck: Forces and moments	Fx	9kN	3
		My	290Nm	
		Fz	14kN	
	Thorax: Deformation and accelerations	Dchest	90mm	4
		Ax, Ay, Az	150g	
	Upper leg: Compression forces (L/R)	Fz	13kN	2
	Knees: Sliding displacements (L/R)	Dknee	19mm	2
	Upper tibia: Forces and moments (L/R)	Fz	12kN	6
		Mx, My	400Nm	
Lower tibia: Forces and moments (L/R)	Fz	12kN	6	
	Mx, My	400Nm		
Second-row HybridIII 5% female dummy	Head: Accelerations	Ax, Ay, Az	250g	3
	Neck forces and moments	Fx	9kN	4
		Fy	9kN	
		Fz	14kN	
		My	290Nm	
	Thorax: Deformation	Dchest	90mm	1
Pelvis: Accelerations	Ax, Az	250g	2	
Ilium force (L/R)	Fx	9kN	2	
Q3 dummy representing a child seated in the second row	Head: Accelerations	Ax, Ay, Az	150g	3
	Neck forces and moments	Fx	3kN	6
		Fy	3kN	
		Fz	6kN	
		Mx, My and Mz	290Nm	
	Thorax: Accelerations	Ax, Ay, Az	150g	3
Thorax compression	Dchest	50mm	1	
Safety belt tension sensor	Driver-side shoulder belt and waist belt	Fbelt	16kN	2
	Front occupant-side shoulder belt and waist belt	Fbelt	16kN	2
	Shoulder belt and waist belt for the second-row female	Fbelt	16kN	2
Accelerometer	B-pillar on the left side of the vehicle	Ax	250g	1
	B-pillar on the right side of the vehicle	Ax	250g	1
Total				85

1.7 Dummy placement and measurement

Two HybridIII 50% male dummies shall be placed on driver's seat and the front outboard occupant seat, respectively, and a HybridIII 5% female dummy on the outboard seat to the left of the second row. A child restraint system is secured onto the outboard seat to the right of the second row, on which a Q-series dummy representing a 3-years-old child is placed; the child restraint system is fixed by safety belt or ISOFIX device. In case the ISOFIX device is only fitted to the outboard seat to the left of the second row, the positions of the child dummy and the female dummy may be interchanged. The instrumentation shall be mounted in the vehicle such that they are not likely to affect the movement of the dummies. Prior to the test, the dummy and instrumentation shall be stabilized in the temperatures as close as possible to the range of 20°C~22°C.

The vehicle shall be preconditioned in the temperatures of 20°C~22°C, to ensure the seat materials are at room temperature. If the seat has never been sat upon, a 75±10kg person or device shall sit on the seat for 1min twice to flex the cushions and back. All seat assemblies shall remain unloaded for at least 30min before the installation of the HPM machine (SAE J826).

The area of the seating position contacted by the HPM machine shall be covered by muslin of adequate size and proper material, for example, plain cotton with 18.9 yarns/cm² and density of 0.228kg/m², or knitted or nonwoven fabric with the same characteristics.

1.7.1.1 Driver and front row occupant

- 1.7.1.1.1 Place the seat and back assembly of the HPM machine on seat so that the centreplane of the seats coincides with the centreplane of the HPM machine.
- 1.7.1.1.2 Attach the foot and lower leg assemblies to the seat pan assembly, line through two "H" point sight buttons shall be parallel to the ground and perpendicular to the longitudinal centreplane of the seat, and length of lower leg and upper leg shall be adjusted to the 10% sight mark.
- 1.7.1.1.3 Both feet and lower leg assemblies shall be moved forward in such a way that the feet take up natural positions on the floor, between the operating pedals if necessary. Where possible, the distance between the left foot and the center plane of the HPM machine should be identical with the distance between the right foot and the center plane of the HPM machine. Confirm that the spirit of the HPM machine is brought to the horizontal by readjustment of the seat pan if necessary, or by adjusting the lower leg and foot assemblies towards the rear. The line passing through two "H" point sight buttons shall be maintained perpendicular to the longitudinal center plane of the seat.
- 1.7.1.1.4 Apply lower leg and thigh weights in turn and confirm again that the HPM machine is leveled.
- 1.7.1.1.5 Tilt the back pan forward against the stop and draw the HPM machine away from the seat-back using the T-bar, if the HPM machine tends to slide rearward, allow the HPM machine to slide rearward until the seat pan contacts the seat-back; if the HPM machine does not tend to slide rearward, then slide the HPM machine rearwards by applying a horizontal rearward force to the T-bar until the seat pan contacts the seat-back.
- 1.7.1.1.6 Apply a 100±10N force to the HPM machine at the intersection of the hip angle quadrant and the T-bar. The direction of force shall be maintained along the thigh bar. Then return the back pan to the seat-back. Throughout the following operation steps, prevent the HPM machine from sliding forward.
- 1.7.1.1.7 Return the back pan to the seat-back, install the left and right buttock weights and then, alternately, torso weights at left and right sides. Confirm that the HPM machine is still maintained at level position.
- 1.7.1.1.8 Pull the back pan upwards to vertical position, hold the T-bar and rock the HPM machine from side to side through range of 5° to each side of the vertical direction for three complete cycles to release any friction between the HPM machine and the seat. During the operation, the T-bar must be maintained at level position by applying an appropriate lateral force to the T-bar, meanwhile, ensure that no forces are applied in a vertical or

fore and aft direction. Furthermore, the feet of the HPM machine are not to be restrained.

1.7.1.1.9 If any movement of the feet has occurred during the rocking operation of the HPM machine, they must be repositioned: alternately, lift each of left and right foot off the floor the minimum necessary amount until no additional foot movement is obtained. During this lifting, the feet are to be free to rotate; and no forward or lateral loads are to be applied. When each foot is placed back in the down position, the heel is to be in contact with the structure designed for this.

1.7.1.1.10 Holding the T-bar to prevent the HPM machine from sliding forward on the seat cushion, return the back pan to the seat-back. Inspect whether the lateral leveler is leveled, if necessary, apply a lateral force on top of back pan so that seat pan of HPM machine is maintained horizontal on seat.

1.7.1.1.11 Alternately apply and release a horizontal rearward force, not to exceed 25N, to the head room probe at a height at the centre of the torso weights of HPM machine until the hip angle quadrant indicates that a stable position has been reached after force release.

1.7.1.1.12 Measure and record the H-point of seat and torso angle.

1.7.1.2 Outer occupant at the second row

1.7.1.2.1 Place the seat and back assembly of the HPM machine on seat so that the centreplane of the seats coincides with the centreplane of the HPM machine.

1.7.1.2.2 Apply thigh weights but don't install lower leg, it is not required to install T-bar in case of interference with vehicle.

1.7.1.2.3 Tilt the back pan forward against the stop and draw the HPM machine away from the seat-back using the T-bar, if the HPM machine tends to slide rearward, allow the HPM machine to slide rearward until the seat pan contacts the seat-back; if the HPM machine does not tend to slide rearward, then slide the HPM machine rearwards by applying a horizontal rearward force to the T-bar until the seat pan contacts the seat-back.

1.7.1.2.4 Apply a 100 ± 10 N force to the HPM machine at the intersection of the hip angle quadrant and the T-bar. The direction of force shall be maintained along the thigh bar. Then return the back pan to the seat-back. Throughout the following operation steps, prevent the HPM machine from sliding forward.

1.7.1.2.5 Return the back pan to the seat-back, install the left and right buttock weights and then, alternately, torso weights at left and right sides. Confirm that the HPM machine is still maintained at level position.

1.7.1.2.6 Pull the back pan upwards to vertical position, hold the T-bar and rock the HPM machine from side to side through range of 5° to each side of the vertical direction for three complete cycles to release any friction between the HPM machine and the seat. During the operation, the seat pan must be maintained at level position by applying an appropriate lateral force to the seat pan, meanwhile, ensure that no forces are applied in a vertical or fore and aft direction.

1.7.1.1.7 Holding the T-bar to prevent the HPM machine from sliding forward on the seat cushion, return the back pan to the seat-back. Inspect whether the lateral leveler is leveled, if necessary, apply a lateral force on top of back pan so that seat pan of HPM machine is maintained horizontal on seat.

1.7.1.2.8 Alternately apply and release a horizontal rearward force, not to exceed 25N, to the head room probe at a height at the centre of the torso weights of HPM machine until the hip angle quadrant indicates that a stable position has been reached after force release.

1.7.1.2.9 Measure and record the H-point of seat, torso angle and coordinate of the foremost point of seat cushion.

1.7.1.2.10 Calculate H-point of HybridIII 5% female dummy by the following formula, in which, X_{SCL} is the distance from H-point to the direction X of the foremost point of seat cushion,

normally X_{AF05} is more forward than X_{AM50} .

$$X_{AF05,dummy} = X_{AM50,H-point\ manikin} + (93mm - 0.323 \times X_{SCL})$$

$$Z_{AF05,dummy} = Z_{AM50, H-point\ manikin} - 6mm$$

1.7.2 Dummy installation

Two HybridIII 50% male dummies shall be placed on the driver's seat and the outside front occupant seat, respectively; a HybridIII 5% female dummy on the outboard seat to the left of the second row; and a child restraint system, together with a Q-series dummy representing a 3-years-old child, on the outboard seat to the right of the second row. The dummy shall not be left to sit directly on the seat for more than 4h prior to the test. If the dummy is in the vehicle for a time longer than 4h but less than 12h, then the dummy shall be sat on plywood boards placed over the seat, to eliminate excessive compression of the seat.

1.7.2.1 Installation of adult dummies

1.7.2.1.1 Place the dummy in the seat with the torso against the seat back, the upper arms against the seat back and the lower arms and hands against the outside of the upper leg.

1.7.2.1.2 Buckle up the safety belt across the dummy. Wearing position of safety belt shall be the natural wearing position, shoulder belt position shall be below the adjusting screw hole of dummy shoulder rotation, otherwise, adjust anchorage position of safety belt until compliance with conditions.

1.7.2.1.3 Apply a small rearwards force to the lower torso and a small forwards force to the upper torso to flex the upper torso forwards from the seat back. Then rock the torso left and right four times, going to 14°~16° to the vertical.

1.7.2.1.4 Maintaining the small rearwards force to the lower torso, apply a small rearwards force to the upper torso to return the upper torso to the seat back.

1.7.2.2 Installation of child dummy and child restraint system

1.7.2.2.1 Installation of child restraint system on the second row of seats

1.7.2.2.1.1 Installation of child restraint system to be secured by adult safety belt

The installation shall be completed in accordance with the user's manual of CRS.

1.7.2.2.1.2 Installation of child restraint system to be secured by ISOFIX device

The installation shall be completed in accordance with the user's manual of CRS. If the installation way of CRS is not indicated in the user's manual, the following principle shall be followed up: in case of the vehicle with top tether anchorage, CRS shall be installed via ISOFIX anchorage and top tether anchorage; in case of the vehicle without top tether anchorage, CRS shall be installed via ISOFIX anchorage and support leg, and the specific installation method is shown in the instruction of CRS.

1.7.2.2.2 Placement of the child dummy onto child restraint system

1.7.2.2.2.1 Place the dummy on the child restraint.

1.7.2.2.2.2 Place a hinged wooden board or a similar bendable device 2.5cm thick and 6cm wide and of length relevant to the dummy size being tested, which is equal to the shoulder height (seating) detracted with the hip centre height (the height of knee joint plus the half of thigh, seating). The board should follow as closely as possible the curvature of the chair and its lower end shall be at the height of the dummy's hip joint.

1.7.2.2.2.3 Adjust the belt in accordance with the manufacturer's instructions, but to a tension of $250 \pm 25N$ above the adjuster force, with a deflection angle of the strap at the adjuster of $45^\circ \pm 5^\circ$, or alternatively, the angle prescribed by the manufacturer.

1.7.2.2.2.4 At the end of adjustment, release the belt, and get out of the board.

1.7.2.2.2.5 Then re-buckle the belt, push the dummy child till it comes to a contact with the CRS back, and adjust CSR to guarantee the strap slackage distributing evenly. Adjust dummy so that its head maintains upright and two legs retain parallel. Raise the dummy's legs, then let them fall down slightly and reside stably at a certain position. Place the hands onto femurs, which shall be secured with adhesive tape.

1.7.3 HybridIII 50% male dummy positioning

Dummy positioning shall be carried out immediately before the test and the vehicle shall not be moved or shaken thereafter until the test has begun. If a test run is suspended accidentally, the dummy positioning and measurement procedure shall be repeated. If the dummy, after three attempts cannot be positioned within the tolerances below then it is to be placed as close to the tolerance limits as possible. Record this in the test details.

1.7.3.1 Head

The transverse instrumentation platform of the head shall be horizontal within 2.5°. To level the head of the test dummy in vehicles with upright seats with non-adjustable backs, the following sequences must be followed. First adjust the position of the "H" point within the limits set forth in Paragraph 1.7.3.5 to level the transverse instrumentation platform of the head of the test dummy. If the transverse instrumentation platform of the head is still not level, then adjust the pelvic angle of the test dummy within the limits provided in Paragraph 1.7.3.6. If the transverse instrumentation platform of the head is still not level, then adjust the neck bracket of the test dummy the minimum amount necessary to ensure that the transverse instrumentation platform of the head is horizontal within 2.5°.

1.7.3.2 Arms

The driver's upper arms shall be adjacent to the torso with the centrelines as close to a vertical plane as possible. The occupant's upper arms shall be in contact with the seat back and the sides of the torso.

1.7.3.3 Hands

The palms of the driver test dummy shall be in contact with the outer part of the steering wheel rim at the rim's horizontal centreline. The thumbs shall be over the steering wheel rim and shall be lightly taped to the steering wheel rim so that if the hand of the test dummy is pushed upward by a force of not less than 9N and not more than 22N, the tape shall release the hand from the steering wheel rim. The palms of the occupant test dummy shall be in contact with outside of thigh. The little finger shall be in contact with the seat cushion.

1.7.3.4 Torso

In vehicles equipped with bench seats, the upper torso of the driver and occupant test dummies shall rest against the seat back. The midsagittal plane of the driver dummy shall be vertical and parallel to the vehicle's longitudinal centreline, and pass through the centre of the steering wheel rim. The midsagittal plane of the occupant dummy shall be vertical and parallel to the vehicle's longitudinal centreline and the same distance from the vehicle's longitudinal centreline as the midsagittal plane of the driver dummy. In vehicles equipped with bucket seats, the upper torso of the driver and occupant test dummies shall rest against the seat back. The midsagittal plane of the driver and the occupant dummy shall be vertical and shall coincide with the longitudinal centreline of the bucket seat.

1.7.3.5 "H" point

The "H" point of the driver and occupant test dummies shall be within 13mm in the vertical dimension and 13mm in the horizontal dimension of a point 6mm below the position of the "H" point determined by using the procedures specified in 1.7.1.1.12.

1.7.3.6 Pelvic angle

The pelvic angle measured from the horizontal on the flat surface of the gauge shall be $22.5^{\circ} \pm 2.5^{\circ}$.

1.7.3.7 Legs

The upper legs of the driver and occupant test dummies shall rest against the seat cushion to the extent permitted by placement of the feet. For the driver, the outboard knee clevis flange surfaces shall fall within the vertical plane, with the left leg residing, to the maximum extent practicable, within the longitudinal vertical plane. For the occupant, the outboard knee clevis flange surfaces shall fall within the vertical plane, with the interval between both surfaces at $270\text{mm}\pm 10\text{mm}$, and, to the maximum extent practicable, both legs shall fall within the longitudinal vertical planes respectively.

1.7.3.8 Feet

The right foot of the driver test dummy shall rest on the undepressed accelerator with the rearmost point of the heel on the floor surface in the plane of the pedal. If the foot cannot be placed on the accelerator pedal, it shall be positioned perpendicular to the tibia and placed as far forward as possible in the direction of the centreline of the pedal with the rearmost point of the heel resting on the floor surface. The heel of the left foot shall be placed as far forward as possible and shall rest on the floorpan. The left foot shall be positioned as flat as possible on the footrest. The longitudinal centreline of the left foot shall be placed as parallel as possible to the longitudinal centreline of the vehicle.

The heels of both feet of the occupant test dummy shall be placed as far forward as possible and shall rest on the floorpan. Both feet shall be positioned as flat as possible on the toe board. The longitudinal centreline of the feet shall be placed as parallel as possible to the longitudinal centreline of the vehicle.

1.7.4 HybridIII 5% female dummy positioning

Dummy positioning shall be carried out immediately before the test and the vehicle shall not be moved or shaken thereafter until the test has begun. If a test run is aborted, the dummy positioning and measurement procedure shall be repeated. If the dummy, after three attempts cannot be positioned within the tolerances below then it is to be placed as close to the tolerance limits as possible. Record this in the test details.

1.7.4.1 Torso

In vehicles equipped with bench seats on the second row, the midsagittal plane of the HybridIII 5% female dummy shall parallel to the longitudinal centerline of the vehicle; in vehicles equipped with bucket seats on the second row, the midsagittal plane of the HybridIII 5% female dummy shall coincide with the longitudinal centreline of the bucket seat; the thigh of the dummy shall rest against the seat cushion to the extent permitted, and angle of leg and thigh is adjusted within $120^{\circ}\pm 5^{\circ}$, the horizontal distance between the centerline of the knees is $160\text{mm}\sim 170\text{mm}$, Push rearward on the dummy's knees to force the pelvis into the seat so there is no gap between the pelvis and the seatback or until contact occurs between the back of the dummy's calves and the front of the seat cushion, with torso resting against the seat back.

1.7.4.2 Head

The transverse instrumentation platform of the head shall be horizontal, with the deviation angle to be ideally controlled within $\pm 5^{\circ}$. For the vehicles with adjustable seat backs of the second row, keep the position of thighs, and place the plane horizontal via adjusting backrest angle forward (or backward); for the vehicles with unadjustable seat backs of the second row, adjust the angle with regulating the lower neck bracket. If the requirement is unable to achieve, place the plane as horizontal as possible, and make record.

1.7.4.3 Pelvic angle

The pelvic angle of the HybridIII 5% female dummy measured from the horizontal on the flat surface of the gauge shall be $20^{\circ}\pm 2.5^{\circ}$. If failed, adjust the angle as close as possible to 20° , and guarantee the head sensor installation surface to adjust according to paragraph 1.7.4.2 and make record. If the head and the pelvic angle couldn't be fulfilled simultaneously, it shall preferentially guarantee the longitudinal plane angle is $0^{\circ}\pm 0.5^{\circ}$.

1.7.4.4 Legs and feet

Keep head, torso and thigh unmoved, adjust angle of legs, to place feet on the floorpan and keep the longitudinal centerline of two feet paralleled with longitudinal centerline of the vehicle as possible; if the feet are unable to reach the floorpan, keep the feet paralleled with the floorpan at the nearest position.

1.7.4.5 Arms

The HybridIII 5% female dummy's upper arms shall be in contact with the seat back and the sides of the torso.

1.7.4.6 Hands

The palms of the HybridIII 5% female dummy shall be in contact with outside of high. The little finger shall be in contact with the seat cushion.

1.7.4.7 "H" point

"H" point of the rear-row HybridIII 5% female dummy shall fall within a range of 13mm respectively from vertical and horizontal directions of H-point determined as per the procedure specified in 1.7.1.2.10.

1.7.5 Measurements of relative positions of dummies

The following measurements are to be recorded prior to the test after the dummy settling and positioning procedures have been carried out, shown in Figure 16.

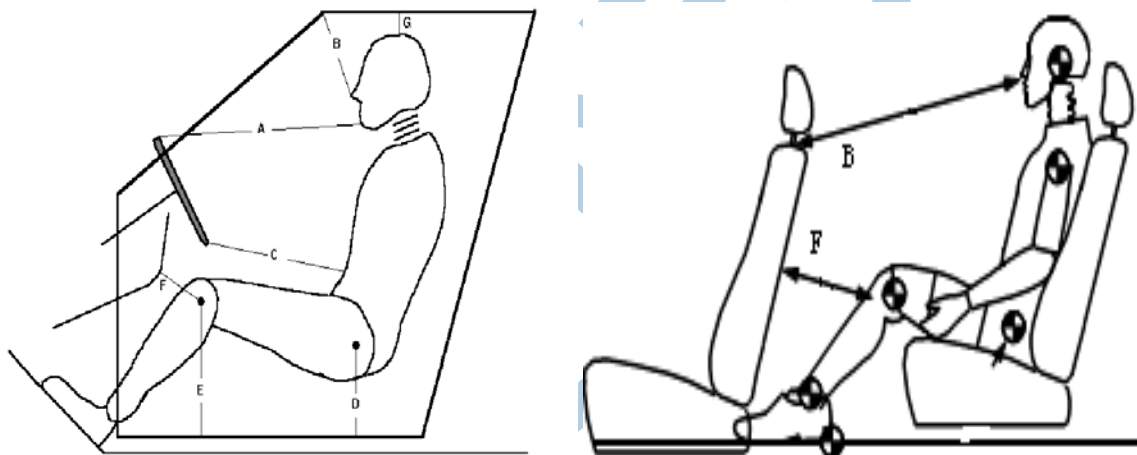

Figure 16 Schematic diagram of measurements of relative positions of dummies

Table 16 Measurements of relative positions of dummies

HybridIII 50% driver-side male dummy		HybridIII 50% front occupant side male dummy		Second-row HybridIII 5% female dummy	
A	Chin to upper rim of steering wheel	A	Chin to dashboard	A	-
B	Nose to top edge of windshield glazing	B	Nose to top edge of windshield glazing	B	Nose to upper center of frontal seat back
C	Abdomen to lower rim of steering wheel	C	Abdomen to dashboard	C	-
D	H-point to door sill	D	H-point to door sill	D	-
E	Knee bolt to top edge of door sill	E	Knee bolt to top edge of door sill	E	-
F	Knee bolt to edge of dashboard	F	Knee bolt to edge of dashboard	F	Knee joint to frontal seat back
G	Head to roof surface	G	Head to roof surface	G	Head to roof surface
H	Neck angle θ	H	Neck angle θ	H	Neck angle θ
I	H-point to vehicle structure	I	H-point to vehicle structure	I	H-point to vehicle structure
J	Actual seat back angle α	J	Actual seat back angle α	J	Actual seat back angle α

1.8 Photographs taken before and after test

The minimum resolution for photographs shall be 640×480. Given in Table 17 are the

minimum quantity and contents of photographs taken before and after the test. "0" represents that photographs shall be taken.

Table 17 Test photographs

No.	View	Pre-test	Post-test
1	Front view of car	0	0
2	Front view of car LHS	0	0
3	Front view of car RHS	0	0
4	Car LHS at 45° to front	0	0
5	Car RHS at 45° to rear	0	0
6	Rear view of car rear	0	0
7	Front view of front windshield glazing	0	0
8	To show area immediately in front of driver	0	0
9	To show area immediately in front of occupant	0	0
10	Side view of driver area	0	0
11	Side view of occupant area	0	0
12	To show driver knees	0	0
13	To show occupant knees	0	0
14	To show driver contacts		0
15	To show occupant contacts		0
16	To show the location of driver's seat	0	0
17	To show the location of occupant seats	0	0
18	Driver and car interior (with doors open)	0	0
19	Occupants and car interior (with doors open)	0	0
20	To show car with its left doors open	0	0
21	To show car with its right doors open	0	0
22	To show the front bottom of car	0	0
23	To show the rear bottom of car	0	0
24	To show area immediately on the left side of rear occupants	0	0
25	To show area immediately on the right side of rear occupants	0	0
26	To show area at 45° to front on the right side of the second-row child occupant	0	0
27	To show area at 45° to front on the left side of the second-row female occupant	0	0
28	To show area in front of the second-row female occupant	0	0
29	To show area in front of the second-row child occupant	0	0

1.9 Camera location

The minimum resolution for camera shall be 512×384. Also, the non-stroboscopic high speed film lighting system is to be used. The camera location and requirements are shown in Table 18.

Table 18 Camera location and requirements

Camera no.	Camera speed	Camera location	Shot content
1	1000fps	Front visual field of windshield glazing	Front view of motions of driver and occupant dummies
2	1000fps	Frontal end to B-pillar on the left side of car	Motion of driver dummy
3	1000fps	B-pillar to C-pillar on the right side of car	Motion of rear occupant dummy
4	1000fps	Entire visual field from barrier to left side of car	Overall motion process of the left part of car
5	1000fps	Frontal end to B-pillar on the right side of car	Motion state of occupant dummy
6	1000fps	Barrier to full visual field from the right side of car	Overall motion process of the right part of car
7	30fps	At 45° to front on the left side of car	Deformation of the left side of car
8	30fps	At 45° to rear on the left side of car	Deformation of the left side of car
9	30fps	Test track	Vehicle motion process
10	30fps	At 45° to front on the right side of car	Deformation of the right side of car
11	1000fps	Interior of rear-row occupant compartment (onboard camera)	Motion attitude of rear-row female dummy

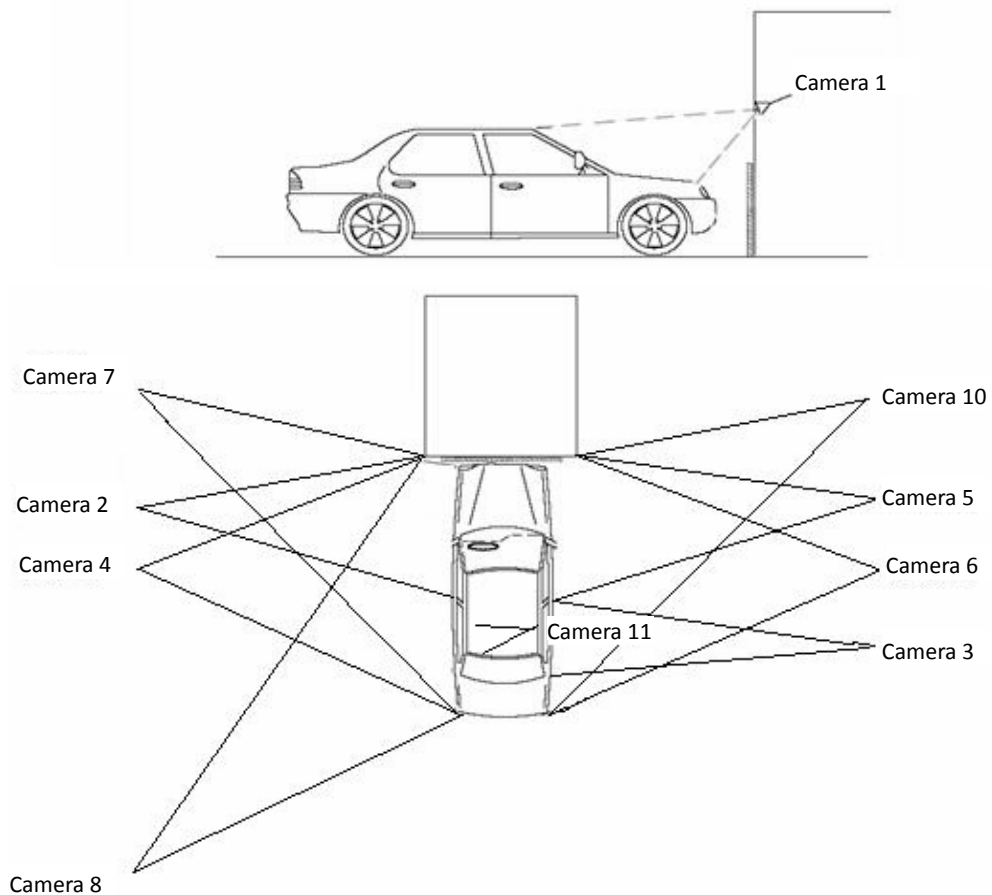

Figure 17 Camera locations for 100% frontal impact test against a rigid barrier

1.10 Test facility

1.10.1 Testing ground

The test area shall be large enough to accommodate the run-up track, the barrier and the technical equipment necessary for the test. The track, for at least 5m before the barrier, shall be horizontal, flat, dry and smooth.

1.10.2 Traction system

The acceleration of the vehicle shall be $\leq 0.3g$, to ensure the location of the dummy before the impact. The vehicle shall be accelerated in such a way: it moves at acceleration in the first half of the run-up track and at a constant speed in the last half. The speed shall be controlled such that it is accurate to $\pm 0.2\text{km/h}$. The test speed is between $50\text{km/h} \sim 51\text{km/h}$. Record the actual test speed.

1.10.3 Lighting system

The non-stroboscopic lighting system for the high speed camera shall be actuated 5min before the test, to ensure the temperature of the impact zone is not unreasonably high.

1.10.4 Position of rigid barrier relative to vehicle

The centerline of the vehicle shall not deviate by $\pm 150\text{mm}$ from the centerline of the surface of the rigid barrier.

1.10.5 Rigid barrier

The rigid wall shall consist of a block of reinforced concrete not less than 3m wide and not less than 1.5m high. The thickness of the rigid wall shall be such that it weighs at least $7 \times 10^4\text{kg}$. The front face shall be vertical, perpendicular to the axis of the run-up-track, and shall be covered by 20mm thick plywood board (see Figure 18). If

necessary, the barrier shall be secured to the ground with additional arresting devices, to prevent any displacement of the barrier. The barrier shall be located such that the impact angle is 0°.

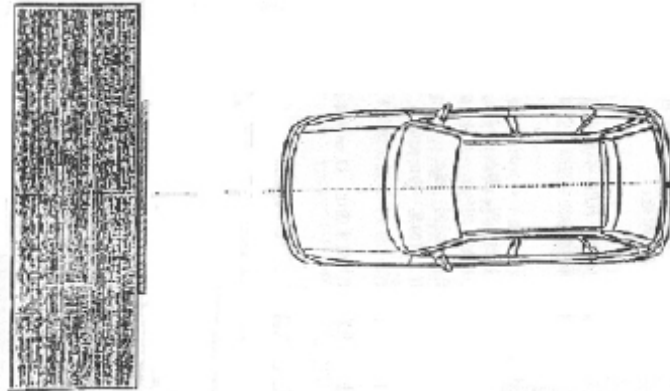

Figure 18 Testing of rigid barrier

1.11 Items to be checked and confirmed before test

1.11.1 Battery

Check that whether the vehicle battery is connected, reaches rated voltage as well as is fastened securely. The battery shall be replaceable.

1.11.2 Ignition switch

The ignition switch shall be placed at “on” position.

1.11.3 Airbag warning light

The airbag switch, where fitted, shall be placed at “on” position, and the airbag light on the dashboard shall illuminate as normal.

1.11.4 Dummy painting

Colored paints shall be applied to the parts of the driver and front occupant dummies such as head, nose, chin, knee and lower leg, etc., to identify and tell them apart. Neck shall be painted red; nose purple; chin blue; left knee red; right knee blue; left lower leg purple, green and blue from top to bottom; right lower leg green, red and purple from top to bottom. All painted areas shall be large enough to enable the dummy’s contacts with the vehicle to be visible. The frontal side of head of female dummy shall be painted in red, the side facing the vehicle door, in green, and the other side, in yellow; in addition, her nose shall be painted in brown, and chin, in blue. For the child dummy, the frontal, left and right sides shall be painted in blue, brown and green, respectively; in addition, left and right knees shall be painted in yellow and brown, respectively.

1.11.5 Checking the on-board data acquisition unit

Ensure that the battery of the on-board data acquisition unit is in a normal working condition prior to the test, and measure the trigger switch at a normal working condition.

1.11.6 Checking doors and latches

Ensure that all doors are completely closed, but not locked prior to the test. For vehicles with automatic lock function, the door should be locked to test.

1.11.7 Electricity-related inspection of pure electric vehicle / hybrid electric vehicles (EV/HEV)

1.11.7.1 Place vehicle startup switch at “ON” position, put vehicle at startup state, confirm traction battery capacity through instrument panel and perform system insulation resistance reference measurement before test.

- 1.11.7.2 Measure the direct contact protection situations of system by using IPXXB test finger.
- 1.11.7.3 Measure the indirect contact protection situations by using measurement equipment.
- 1.12 Items to be checked and confirmed after test
- 1.12.1 **Safety belt**
With regard to the safety belts for driver, front occupant and rear occupant dummies, check whether they fail or not during the test.
- 1.12.2 **Doors**
Inspect whether doors are locked or not. After the test, inspect whether the side doors corresponding to each row of seats can be opened without any tools.
- 1.12.3 **Fuel feeding system**
After the impact test, check whether the feeding system leaks or not. If constant leakage occurs in the fuel feeding system, measure the amount of fuel leaked in the first 5min after the impact test. Calculate the average leaking rate.
- 1.12.4 **Opening force of safety belt buckle**
Measure and record the forces applied to open the safety belt buckles for driver, front occupant and rear occupant dummies.
- 1.12.5 **Measurement inspection of pure electric vehicle/hybrid electric vehicle (EV/HEV)**
 - 1.12.5.1 **Protection against electric shock**
 - 1.12.5.1.1 **Insulation resistance at REESS side**

The insulation resistance at REESS side should be measured as per the following steps:
Measure and record the voltage (V_b) between the negative pole side and the positive pole of high voltage bus, voltage (V_1) between the negative pole side and electric chassis, and the voltage (V_2) between the positive pole and electric chassis, as shown in Figure 19:

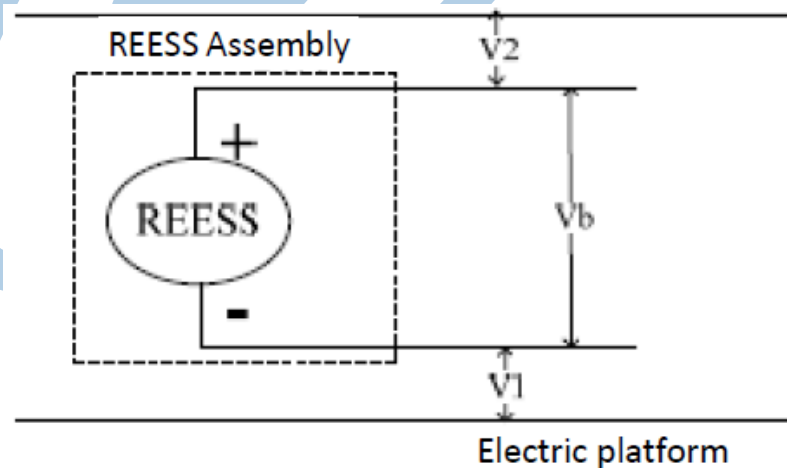

Figure 19 Schematic diagram of REESS side voltage measurement circuit

If V_1 is greater than or equal to V_2 , insert a standard known resistance (R_0) between the negative pole side of high voltage bus and electric chassis. With R_0 installed, measure the voltage (V_1') between the negative pole side of high voltage bus and electric chassis of vehicle, as shown in Figure 20:

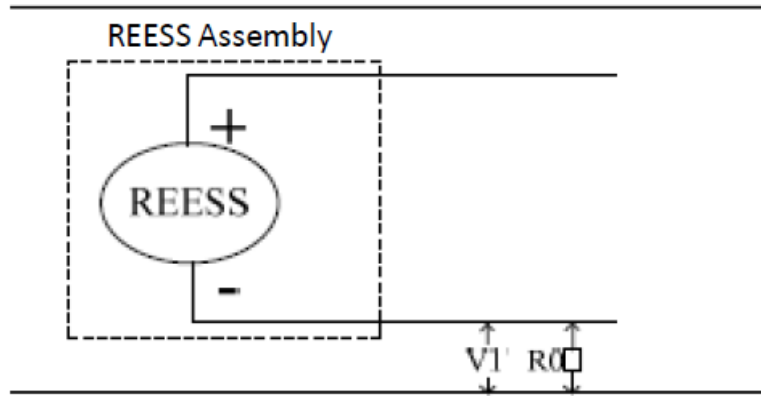

Figure 20 Schematic diagram of circuit incorporating resistance R0 into negative pole side of REESS

Calculate the insulation resistance (R_i) according to the following formula:

$$R_i = R_0 \times (V_b/V_1' - V_b/V_1) \text{ or } R_i = R_0 \times V_b \times (1/V_1' - 1/V_1)$$

If V_2 is greater than V_1 , insert a standard known resistance (R_0) between the positive pole side of high voltage bus and electric chassis. With R_0 installed, measure the voltage (V_2') between the positive pole side of high voltage bus and electric chassis of vehicle, as shown in Figure 21:

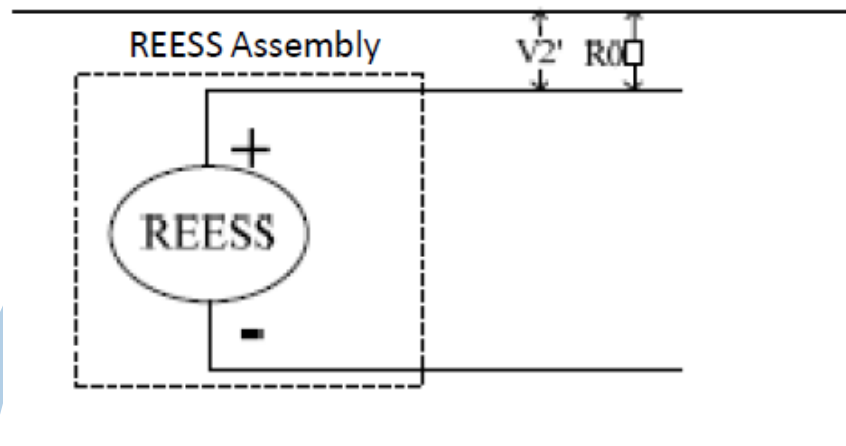

Figure 21 Schematic diagram of circuit of incorporating resistance R0 into positive pole side of REESS

Calculate the insulation resistance (R_i) according to the following formula.

$$R_i = R_0 \times (V_b/V_2' - V_b/V_2) \text{ or } R_i = R_0 \times V_b \times (1/V_2' - 1/V_2)$$

Dividing the result R_i (electrical insulation resistance value, in unit of Ω) by the working voltage of the high voltage bus (in unit of V).

$$R(\Omega/V) = R_i(\Omega) / \text{working voltage (V)}$$

Note: The standard known resistance R_0 (Ω) should be equivalent to the minimum value of the required insulation resistance (in unit of Ω/V) multiplied by the working voltage of vehicle (in unit of V), but it is only allowed to float by $\pm 20\%$.

1.12.5.1.2 Voltage measurement

Within 5s-60s after end of the impact test and stop of vehicle, measure voltage (V_b , V_1 and V_2) of high voltage bus, as shown in Figure 22.

Within the above mentioned measurement time, it is allowed to perform measurement of voltage for multiple times, and select one group of the minimum voltage measurement

values as measurement result.

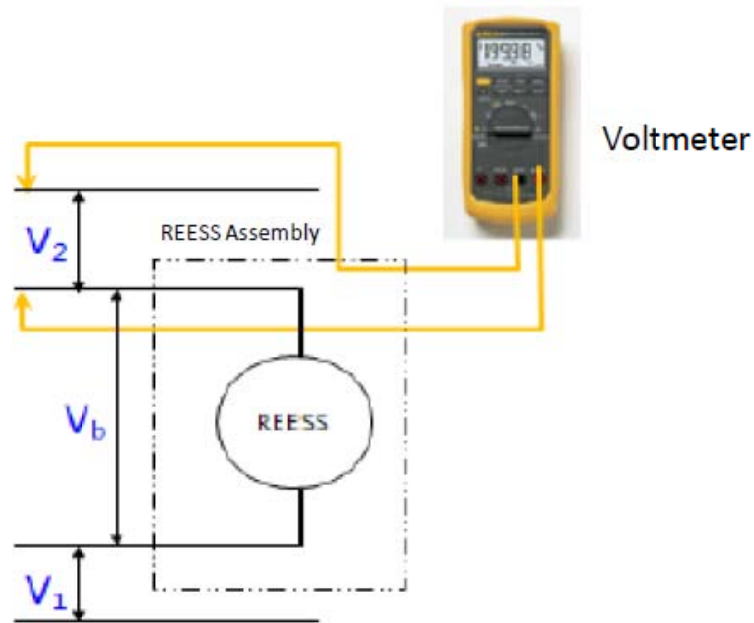

Figure 22 Schematic diagram of voltage measurement

1.12.5.1.3 Electric energy measurement

Prior to the impact test, switch S1 and a known discharge resistance R_e are connected in parallel to the relevant capacitance and keep side S1 open, as shown in Figure 23.

Within 5s-60s after end of impact test and stop of vehicle, the switch S1 should be closed while the voltage V_b and the current I_e are measured and recorded. The product of V_b and I_e should be integrated over the period of time (starting from the moment T_c when S1 is closed until the moment T_h when the voltage V_b falls below the high voltage threshold of 60V DC). The resulting integration equals the total energy TE in unit of joules, the calculation formula is as follows:

$$TE = \int_{T_c}^{T_h} V_b \times I_e$$

If V_b is measured at a time point between 5s-60s after the impact and the capacitance of the X-capacitors (C_x) is specified by the manufacturer, total energy TE should be calculated according to the following formula:

$$TE = 0.5 \times C_x \times (V_{b2} - 3600)$$

If V_1 and V_2 are measured at a time point between 5s-60s after the impact and the capacitances of the Y-capacitors (C_{y1} , C_{y2}) are specified by the manufacturer, total energy T_{Ey1} and T_{Ey2} should be calculated respectively according to the following formulas:

$$T_{Ey1} = 0.5 \times C_{y1} \times (V_1^2 - 3600)$$

$$T_{Ey2} = 0.5 \times C_{y2} \times (V_2^2 - 3600)$$

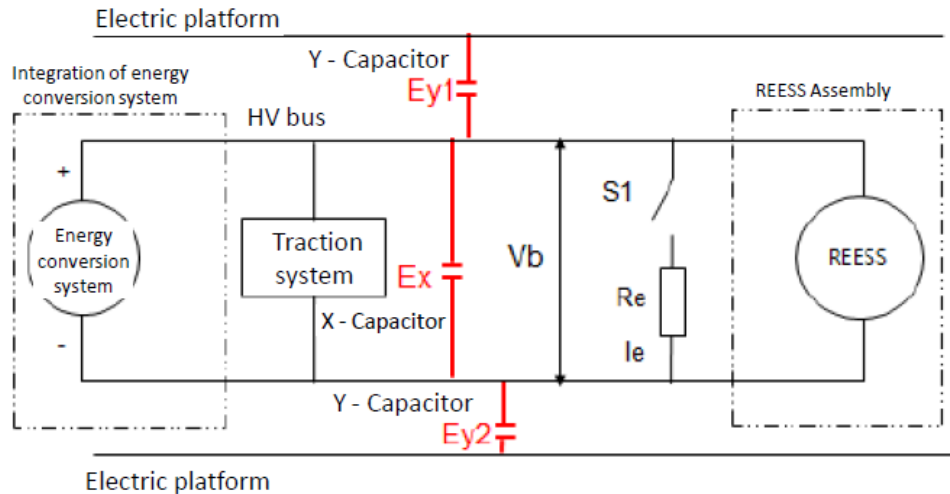

Figure 23 Schematic diagram of electric energy measurement

1.12.5.1.4 Physical protection measurement

1.12.5.1.4.1 Direct contact measurement

Following the impact test, any parts surrounding the high voltage components should be, without the use of tools, opened, disassembled or removed. All remaining surrounding components should be considered part of the human body protection. In which, internal barrier is deemed as a part of enclosure.

The jointed test finger (IPXXB) defined in GB 4208 should be inserted into any gaps or openings of the physical protection, the test force used should be (10 ± 1) N.

If partial or full penetration into the physical protection by the jointed test finger occurs, the jointed test finger should be placed in every position as specified below. Starting from the straight line position, both joints of the test finger should be rotated progressively through an angle of up to 90° with respect to the axis of the adjoining section of the test finger and should be placed in every possible position.

A mirror or a fiberscope may be used in order to inspect whether the jointed test finger touches the high voltage bus, or a low voltage signal circuit may be used in order to inspect whether the jointed test finger touches the high voltage live part.

1.12.5.1.4.2 Indirect contact measurement

For balance of potential between all exposed conductive parts and electric chassis, perform measurement test.

During test, apply a test DC current between exposed conductive parts and electric chassis, the DC test current should be not less than 0.2A and voltage should be less than 60V, maintain test duration for over 5s to get stable test data.

If the test result of balance potential resistance can maintain sufficient accuracy, it is allowed to use lower test current and/or shorter test duration.

1.12.5.1.5 Measurement of insulation resistance at load side of power system

During measurement of insulation resistance at load side of power system, apply an external DC voltage not less than the maximum working voltage of class B power system between high voltage bus and electric chassis, and perform measurement by using appropriate equipment (such as megohmmeter).

During test, respectively connect positive pole (or negative pole) of test equipment with positive pole/negative pole of high voltage bus, connect negative pole (or positive pole) of test equipment with electric chassis, then apply voltage for sufficient time duration to get stable reading. If the system has several live parts of different voltage classes (f.g.

voltage boosting converter is included), it is allowed to apply the respective maximum working voltage to perform measurement of insulation resistance, see the schematic diagram of measurement as per Figure 24:

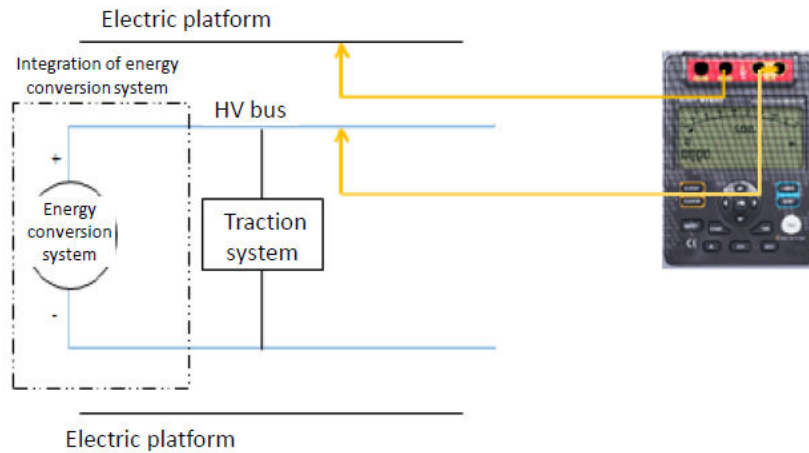

Figure 24 Schematic diagram of measurement of insulation resistance at load side of power system

Take R_i of low test result as the insulation resistance (electrical insulation resistance value, in unit of Ω) between high voltage bus and electric chassis, then divide it by the working voltage of the high voltage bus (in unit of V), the results should be insulation resistance value.

$$R_i (\Omega / V) = R_i (\Omega) / \text{Working voltage (V)}$$

Furthermore, the insulation resistance can be measured by connecting power system load with external power supply as per the test steps for insulation resistance at REESS side in 1.12.5.1.1.

1.12.5.2 Measurement of electrolyte leakage volume

1.12.5.2.1 Within 30min after end of impact test and stop of vehicle, perform monitoring of electrolyte leakage situations.

1.12.5.2.2 Place liquid collection container at the leakage source position to collect all liquids. Perform separation of the collected liquid, it is allowed to identify the leaked liquid through litmus paper, or perform liquid separation through chemical means; if manufacturer did not provide separation or identification method, it is necessary to deem all leaked liquid as electrolyte and measure its leakage volume.

1.12.5.2.3 Determine whether electrolyte leaks into occupant compartment by visual inspection method.

1.12.5.3 REESS safety measurement

1.12.5.3.1 Position measurement

Through change situations of painted marking of vehicle traction battery fixing position before and after test, measure the movement of REESS, and visually inspect whether REESS invades occupant compartment; for REESS installed in occupant compartment, inspect whether it is maintained in installation position, whether REESS parts are maintained in its enclosure.

1.12.5.3.2 Fire and explosion measurement

Within 30min after end of impact, visually inspect whether there is fire or explosion phenomenon in REESS.

1.12.5.4 Activation of high voltage automatic disconnection device

For vehicle configured with high voltage automatic disconnection device, if manufacturer determines to perform verification test for validity of high voltage automatic disconnection device, then the verification test method can be determined by manufacturer and C-NCAP Administration Center through joint negotiation.

1.13 Dummy injury index calculation

Table 19 lists sensor CFC of all the measurement locations. Record all these channel data. Head impacts occurring after the dummy head rebounds from an initial contact are not considered when calculating injury criteria of head and neck.

Table 19 Channel frequency class (CFC) of sensor

	Location	Parameter	CFC	Calculation of injury parameters
HybridIII 50% male dummy	Head	Accelerations Ax, Ay, Az	1,000	HIC36 Resultant 3ms exceeding
	Neck	Forces Fx, Fz	1,000	Tension (Fz) continuous exceeding Shear (Fx) continuous exceeding Peak extension (My) i
		Moments My	600	
	Thorax	Deflection Dchest	180	Peak deflection VC value Resultant 3ms exceeding
		Accelerations Ax, Ay, Az		
	Upper leg: Compression forces (L/R)	Forces Fz	600	Compressive axial force (-Fz) Continuous exceeding
	Knees: Sliding displacements (L/R)	Displacements Dknee	180	Peak displacement
	Upper tibia: Forces and moments (L/R)	Forces Fz	600	Peak tibia compression Tibia Index
Moments Mx, My				
Lower tibia: Forces and moments (L/R)	Forces Fz	600	Peak tibia compression Tibia Index	
	Moments Mx, My			
Hybrid III 5% female dummy	Head	Accelerations Ax, Ay, Az	1,000	HIC15
	Neck	Forces Fx, Fy, Fz	1,000	Peak neck force
		Moments My	600	Peak extension (My) i
	Thorax	Deflection Dchest	600	Peak deflection
	Pelvis	Accelerations Ax, Az	1,000	Resultant accelerations
Ilium force Fx		180	Force unloading ratio	
Car Body	B- pillar	Accelerations Acc	60	Car body acceleration

1.13.1 HybridIII 50% male dummy

1.13.1.1 Head

$$A_R = \sqrt{A_x^2 + A_y^2 + A_z^2}$$

$$HIC = (t_2 - t_1) \left[\frac{\int_{t_1}^{t_2} A_R \cdot dt}{(t_2 - t_1)} \right]^{2.5}$$

Where Ax, Ay, Az -- Represent accelerations in three dimensions, expressed in g, and $t_2 - t_1 \leq 36\text{ms}$. Calculate resultant accelerations for a cumulative time period of 3ms.

1.13.1.2 Neck

Calculate the neck extension bending moment from:

$$(My)_j = My - Fx \cdot d$$

Where My and Fx are bending moment and shearing force respectively measured at the transducer and d is the distance from the transducer to the interface (SAE J1733) d=0.01778. Determine the 'continuous exceeding' of both the neck tension (Fz) and neck shear (Fx) forces.

1.13.1.3 Thorax

Determine the peak thorax deformation and calculate VC value of thorax.

Calculate the VC value of thorax from

$$(VC)_{(t)} = 1.3V_{(t)} \times C_{(t)}$$

$$C_{(t)} = \frac{D_{(t)}}{0.229}$$

The rib deformation rate at the time t is obtained based on the deformation which is filtered.

$$V_{(t)} = \frac{8[D_{(t+1)} - D_{(t-1)}] - [D_{(t+2)} - D_{(t-2)}]}{12\delta t}$$

Where: $D(t)$ is the deformation at the time t (m); δt represents the interval for measurement of deflection (s).

1.13.1.4 Upper leg

Determine the axial compressive force on a continuous basis.

1.13.1.5 Knee sliding displacement

Determine the peak knee sliding displacement.

1.13.1.6 Lower leg

Calculate TI :

$$M_R = \sqrt{(M_X)^2 + (M_Y)^2}$$

$$TI = |M_R / (M_C)_R| + |F_Z / (F_C)_Z|$$

Where:

M_X -- The bending moment about the y axis;

M_Y -- The bending moment about the x axis;

$(M_C)_R$ -- The critical value of the bending moment = 225Nm;

F_Z -- The axial compressive force in vertical direction (z);

$(F_C)_Z$ -- The critical value of the compressive force = 35.9kN;

The peak value of TI and the peak axial compressive force.

1.13.2 HybridIII 5% female dummy

1.13.2.1 Head

$$A_R = \sqrt{A_x^2 + A_y^2 + A_z^2}$$

$$HIC = (t_2 - t_1) \left[\frac{\int_{t_1}^{t_2} A_R \cdot dt}{(t_2 - t_1)} \right]^{2.5}$$

Where: A_x, A_y, A_z -- Acceleration values in three directions, expressed in g, $t_2 - t_1 \leq 15$ ms.

1.13.2.2 Neck

Calculate the extensional bending moment of neck:

$$(My)_i = My - Fx \cdot d$$

Where, My and Fx are the measured values of transducer, and d is the distance from the center of transducer to head-neck intersection plane (SAE J1733) $d=0.01778$. Determine the peak value of extensional bending moment (Fz) and shearing force (Fx) of the neck.

1.13.2.3 Thorax

Determine the peak compressive deformation of thorax.

1.13.2.4 Pelvis

Calculate speed of pelvis through X-direction and Z-direction resultant acceleration of pelvis, and take the instant when the relative velocity is identical with vehicle body as pelvis bouncing 0 instant.

2 Frontal impact test against deformable barrier with 40% overlapping

2.1 Vehicle preparation

2.1.1 Checking and confirming vehicle(s) upon arrival

When the test vehicle arrives at the laboratory, the C-NCAP logo and the vehicle's unique identification - the test number and the laboratory information shall be attached to the vehicle. And measure and record the mass of the vehicle and its front and rear axle loads. Check and confirm the appearance, configuration and basic parameters of the vehicle (Appendix 3).

2.1.2 Common fuel vehicle

2.1.2.1 Measurement of vehicle kerb mass

2.1.2.1.1 Drain the fuel from the tank and then run the engine until it has run out of fuel.

2.1.2.1.2 Calculate the mass of fuel contained in the fuel tank at its rated capacity, using a density for petrol of 0.74g/ml or 0.84g/ml for diesel. The fuel tank shall be filled with water to mass equal to 90 percent of the mass of a fuel.

2.1.2.1.3 Check and adjust tyre pressure according to the manufacturer's instructions for half load. Check and top up the levels of all other fluids (e.g., engine oil, transmission fluid, brake fluid, washing fluid, antifreeze, etc.) to their maximum levels. Confirm the spare tyre and driver tool are on-board. Nothing else shall be in the vehicle.

2.1.2.1.4 Measure and record the height of the intersection point between the transverse plan passing through the centers of the 4 wheels and the upper edge of the wheel guard plate.

2.1.2.1.5 Measure and record the mass of the vehicle and its front and rear axle loads. The mass of the vehicle is the kerb mass of the complete vehicle.

2.1.2.2 Vehicle preparation and installation of test equipments

2.1.2.2.1 Drain the engine oil, transmission fluid, brake fluid, washing fluid, antifreeze, power assisted fluid, etc. In this case, the mass of the liquids shall be offset. Drain the fluids in the air conditioning system.

2.1.2.2.2 Remove the carpet in the luggage compartment, driver tool and spare tyres from the vehicle (make sure that it will not affect the crash performance of the vehicle).

2.1.2.2.3 Fix the on-board data acquisition equipment. Also install one-way accelerometers at the sills beneath the B-pillars on the left and right sides of the vehicle.

2.1.2.2.4 Measure the mass of the vehicle and its front and rear axle loads. Compare them with those determined in Paragraph 2.1.2.1.5. The load of each axle shall not differ from

them by more than 5 percent, each variation not exceeding 20kg, and the mass of the vehicle by more than 25kg. Any component not liable to affect the crash performance of the vehicle may be added or removed and the mass of the water in the fuel tank may be adjusted to help achieve the desired weights. Record the final mass of the vehicle and its final front and rear axle loads.

- 2.1.2.2.5 Upon completion of the test described in Paragraph 2.6.2, measure and record the mass of the vehicle and its front and rear axle loads. The mass of the vehicle determined herein is the test mass (including dummy and all instrumentation). Measure and record the height of the intersection point between the transverse plan passing through the centers of the four wheels and the upper edge of the wheel guard.

2.1.4 Tape C-NCAP logo and vehicle mark

The testing vehicle shall be attached C-NCAP logo and vehicle unique identification-Test code and lab information.

2.1.3 Pure electric vehicle/hybrid electric vehicle (EV/HEV)

2.1.3.1 Report and registration of basic information of vehicle

Vehicle manufacturer should submit information related to high voltage system and its assembly layout and/or position to C-NCAP Administration Center, including:

- 2.1.3.1.1 Layout diagram and/or photo of high voltage system and its assembly, and layout position indicating rechargeable energy storage system (REESS).
- 2.1.3.1.2 Explanatory drawing and written record material related to fixture method of REESS.
- 2.1.3.1.3 Material description related to battery type of REESS, battery capacity, electrolyte composition and its total volume, etc.
- 2.1.3.1.4 For vehicle featuring high voltage automatic disconnection device, if manufacturer determines to perform verification test for validity of device, then it is necessary to provide the position of automatic disconnection device of vehicle, and briefly describe its working theory or working method.

2.1.3.2 Vehicle charging

Before test, it is necessary to charge traction battery. Impact test of battery electric vehicle and plug-in hybrid electric vehicle should be performed within 24h after end of charge of vehicle.

- 2.1.3.2.1 For plug-in battery electric vehicle and hybrid electric vehicle, it is allowed to charge traction battery to the maximum state of charge as per the requirement of manufacturer.
- 2.1.3.2.2 For plug-in battery electric vehicle and hybrid electric vehicle, perform full charge of traction battery as per clause 5.1 of GB/T 18385-2005 if manufacturer has no requirement.
- 2.1.3.2.3 For non-plug-in hybrid electric vehicle, prepare test as per the normal operating conditions of vehicle.

2.1.3.3 Measurement of kerb mass of vehicle

If vehicle is equipped with traction battery liquid cooling system, it is necessary to drain coolant after completion of charging, and replace with equivalent mass of liquid of color different from electrolyte of traction battery. For hybrid electric vehicle, it is also necessary to perform fuel treatment as per 2.1.2.1.1-2.1.2.1.2. Then proceed with measurement of kerb mass of vehicle as per 2.1.2.1.3-2.1.2.1.5.

2.1.3.4 Measurement of reference mass of vehicle

Perform measurement of reference mass of vehicle as per 2.1.2.2.

2.1.3.5 Preparation of vehicle and installation of test equipments

Drain fluids such as brake fluid, detergent, anti-freeze fluid and steering assistance fluid, and compensate the mass of the discharged fluids. Drain the liquid in air conditioning system. Proceed with preparation of vehicle and installation of test equipments as per 2.1.2.2.2-2.1.2.2.5.

2.1.3.6 Determination of measurement point of electrical safety

- 2.1.3.6.1 Determine the measurement point of insulation resistance at traction battery side, and measure the voltage of positive/negative poles of traction battery side and the voltage between positive/negative poles of traction battery and electric chassis.
- 2.1.3.6.2 Determine insulation resistance measurement points of the power system load-side, and measure the positive and negative voltages at load-side, and voltage between the load positive and the electric chassis, and voltage between the load negative and the electric chassis.
- 2.1.3.6.3 Mark on fixed positions of REESS assembly in testing vehicle for displacement and separation measurement of REESS assembly after the impact.

2.2 Measurement of vehicle deformation

For vehicle deformation measurement, a 3D measuring system (the software shall present the coordinate conversion function: an appropriate coordinate system could be automatically generated based on the inputs of the coordinate values of several points) can be used. The system requires a coordinate system to be set up relative to a particular plane, with its axes being in the same directions of those of the vehicle coordinate system. During the testing, some structure at the rear of the vehicle can be used as a reference for measurement. During the measurement, the vehicle shall be in a state described in Paragraph 2.1.2.2.4.

2.2.1 Before test

- 2.2.1.1 Mark the center of the clutch, brake, accelerator and parking brake pedals (if any). If adjustable, the pedals will be placed at the middle position or at the position recommended by the manufacturer.
- 2.2.1.2 The steering wheel, if adjustable, shall be placed in the midway between the limits of its range(s) of adjustment in any direction.
- 2.2.1.3 The ignition switch shall be placed at "off" position and the battery shall be disconnected.
- 2.2.1.4 Remove the components equipped at the center of the steering wheel or, if fitted, the airbag to expose the end of the steering column. When doing this, carefully mark the connection lines to the airbag which will need to be remade on re-assembly. The removal of the airbag or the components equipped at the center of the steering wheel shall follow the instruction recommended by vehicle manufacturer.
- 2.2.1.5 Mark the center of the top of the steering-column.
- 2.2.1.6 Set up the coordinate system of vehicle bodywork, by applying either of the following procedures:
 - 2.2.1.6.1 Provided, for the non-deformation locations at the rear end of the vehicle (left, right, and middle), manufacturer could furnish the coordinate values of 8 characteristic points (spatially scattered to the maximum practicable extent, and convenient for measurement) under the designed bodywork coordinate system for the vehicle, record them, based on which the designed bodywork coordinate system is subsequently set up through the use of software.
 - 2.2.1.6.2 Provided manufacturer could not furnish the 8 characteristic points described in Paragraph 2.2.1.6.1, set up the bodywork coordinate system as follows: Adjust the vehicle until the horizontal level is attained; mark the position of at least 8 datum points (spatially scattered to the maximum practicable extent) on the rear end of the vehicle (left, right and middle), which are not expected to deform in the test. Among them, 1 point serves as the original point of the coordinate, and two points are taken to establish

the x or y axis, which is in parallel with the corresponding axis of the bodywork coordinate system. Where such two points are not available on the vehicle body, then two points that are basically in parallel with the corresponding axis of the vehicle coordinate system are to be given by the manufacturer. Establish a 'z' plane on the ground on which the vehicle stays, and horizontally moves it through the original point of the coordinate. Record the coordinate values of 8 characteristic points.

2.2.1.7 Measure and record the center of the clutch, brake, accelerator and, if fitted, parking brake pedals as well as the coordinate located in the marked center of the top of the steering-column.

2.2.1.8 Measure and record the B-pillars on the occupant side:

I At a distance of 100mm above the sill;

II At a distance of 100mm beneath the lowest level of the side window frames.

All points should be as close as possible to the rubber sealing strip around the door aperture.

2.2.1.9 Measure and record the A and B-pillars on the driver side:

I At a distance of 100mm above the sill;

II At a distance of 100mm beneath the lowest level of the side window frames.

All points should be as close as possible to the rubber sealing strip around the door aperture.

2.2.1.10 Refix the component in the centre of the steering wheel, and check all bolts are securely fastened.

2.2.1.11 Connect the battery, check whether the circuit is functional or not. Ensure that airbags are in a normal working condition.

2.2.2 After test

2.2.2.1 Measure the distance between each pedal to a fixed point of the vehicle before the dummy is removed. Where it is not possible to make such measurement, then first remove the dummy, provided that the post-impact positions of pedals are not to be changed as far as possible during the test. The distance shall be re-measured after the dummy is removed. In the case of any change in the positions of pedals, use the distance measured and reposition the pedals.

2.2.2.2 Remove the central parts of the steering wheel.

2.2.2.3 Measure the 8 characteristic points measured (datum points) prior to the test.

2.2.2.4 Set up the bodywork coordinate system. With the software, input the pre-test coordinate values of any 6 points among the 8 characteristic points (datum points), so as to set up, via the software, the bodywork coordinate system based on the coordinate values of these 6 points. In the newly-established coordinate system, compare the coordinate values of such 6 points with their pre-test counterparts; in case of low consistency, randomly select 6 out of the 8 characteristic points (datum points) to re-establish the bodywork coordinate system, and conduct comparison again. In case the consistency is low either, correct the measurement values in accordance with the procedures shown in Paragraph 2.2.3.

2.2.2.5 Measure and record the centre of the clutch, service brake, accelerator, and, if fitted, parking brake pedals, as well as the coordinate located in the marked centre of the top of the steering-column. If a pedal is disengaged, then such pedal is not subject to measurement.

2.2.2.6 Measure and record the mark on A-pillar.

2.2.3 Correction

- 2.2.3.1 After the test, measure and record the marks on the driver and occupant-side B-pillar.
- 2.2.3.2 Compare the changes in positions of related B-pillar points above the z axis before and after the test.
- 2.2.3.3 Find the angle θ that best satisfies the following equation: $z = -x_l \sin\theta + z_l \cos\theta$ for the B-pillar sill point (where z = pre-impact vertical measurement, and x_l, z_l = post-impact longitudinal and vertical measurement).
- 2.2.3.4 Transform the post impact longitudinal and vertical measurements (x, z) using the following equations:

$$\begin{bmatrix} X \\ Z \end{bmatrix} = \begin{bmatrix} \cos \theta & \sin \theta \\ -\sin \theta & \cos \theta \end{bmatrix} \begin{bmatrix} x_l \\ z_l \end{bmatrix}$$

Note: X, Z = the corrected coordinate values, x_l, z_l = the actual values measured after the impact.

2.2.4 Results

The following measurement results may be obtained based on the pre-impact measurements and post impact measurements (or the post impact measurements modified).

- 2.2.4.1 The longitudinal and vertical displacements of steering-column.
- 2.2.4.2 The longitudinal and vertical displacements of all pedals.
- 2.2.4.3 The longitudinal displacement of A-pillar at its horizontal level.

2.3 Occupant compartment adjustments

2.3.1 Front seat adjustments

- 2.3.1.1 Front seats adjustable longitudinally shall be placed in the middle position of travel or in the nearest backward locking position. Check and confirm the seat sliding system is in a completely locked position.
- 2.3.1.2 Front seats independently adjustable for height shall be placed at the height position defined by the manufacturer or the lowest position.
- 2.3.1.3 Seat cushions adjustable for inclination shall be adjusted to the position defined by the manufacturer or the middle position.
- 2.3.1.4 If adjustable, the seat-backs shall be adjusted so that the resulting inclination of the torso of HPM machine is as close as possible to that recommended by the manufacturer for normal use or, in the absence of any particular recommendation by the manufacturer, to 25° towards the rear from the vertical.
- 2.3.1.5 Where adjustable, the lumbar support shall be placed at the position defined by the manufacturer or the completely retracted position.
- 2.3.1.6 Head restraints adjustable for height shall be in their uppermost position.
- 2.3.1.7 Head restraints adjustable for inclination shall be adjusted to the position defined by the manufacturer or the middle position.
- 2.3.1.8 Arm-rests shall be in the lowered position, unless this is prevented by the position of the dummies in the vehicles.
- 2.3.1.9 Other adjustment mechanisms shall be set to the manufacturer's design position.

2.3.2 Adjustment of the second row of seats

- 2.3.2.1 The second-row seats adjustable longitudinally shall be placed in the middle position of travel or in the nearest rearward locking position. Check and confirm the seat sliding system is in a completely locked position.

- 2.3.2.2 For a second-row seat allowing vertical adjustment, seat height shall be set to the manufacturer's design position or the lowest position.
- 2.3.2.3 For a second-row seat with adjustable seat back, the seat back shall be adjusted to the manufacturer's design angle or the position inclining backwards by 23° from the vertical plane.
- 2.3.2.4 Lumbar support, if any, for second-row seat shall be adjusted to the manufacturer's design position or the fully retracted position.
- 2.3.2.5 Head rests of the second-row seats shall be adjusted to the lowest locking position.
- 2.3.2.6 If the tilt angle is adjustable, head rest shall be adjusted to the foremost position.
- 2.3.2.7 Rear seats adjustable for orientation shall be adjusted to forward facing.
- 2.3.2.8 Other adjustment mechanisms shall be set to the manufacturer's design position.
- 2.3.3 Steering wheel adjustments**
- 2.3.3.1 The steering wheel adjustable horizontally shall be placed in midway between the limits of its range(s) of adjustment.
- 2.3.3.2 The steering wheel adjustable vertically shall be placed in midway between the limits of its range(s) of adjustment.
- 2.3.3.3 The steering wheel shall be left free, with its spokes in the position which according to the manufacturer corresponds to straight-ahead travel of the vehicle.
- 2.3.4 Adjustment of safety belt anchorages**
- Where adjustable, safety belt anchorages shall be placed in the position defined by the manufacturer or the middle position, or close to the fixed upper midway.
- 2.3.5 Gear-change lever**
- The gear-change lever shall be in the neutral position.
- 2.3.6 Glass**
- The movable glass of the vehicle shall be in the closed position, meanwhile the position of the operating handle corresponds to the closed position of the glass.
- 2.3.7 Pedals**
- The pedals shall be in their normal released position.
- 2.3.8 Sun-visor**
- The sun-visors shall be in the stowed position.
- 2.3.9 Rear-view mirror**
- The interior rear-view mirror shall be in the normal position of use.
- 2.3.10 Doors and lock**
- The doors shall be closed but not locked. For vehicles with automatic door lock function, the door should be locked to test.
- 2.3.11 Opening roof**
- If an opening or removable roof is fitted, it shall be in place and in the closed position.
- 2.3.12 Parking brake**
- Parking brakes shall be released.
- 2.4 Dummy preparation and calibration**

During the test, two HybridIII 50% male dummies and one HybridIII 5% female dummies are to be used. Each dummy will be clothed with formfitting cotton stretch garments with short sleeves and pants and fitted with shoes. Neck shields shall be fitted to HybridIII 50% male dummies if a frontal protection airbag is present. Moreover, each dummy shall be fitted with the neck protection sheath.

2.4.1 Ambient conditions for dummy tests

- 2.4.1.1 The dummy shall be tested at the temperature of 20°C~22°C and the humidity of 10%~70%.
- 2.4.1.2 The dummy shall be placed in temperatures specified in Paragraph 2.4.1.1 for at least 5h prior to the calibration of the dummy, the adjustment of dummy joints and the impact test.

2.4.2 Adjustment of dummy joints

- 2.4.2.1 The dummy joints should be adjusted as close as possible to the time of the test and, in any case, not more than 24h before the test.
- 2.4.2.2 All constant friction joints shall be subject to adjustment. When a force being 1g~2g is applied, the dummy limbs can continue to move.

2.4.3 Calibration of dummies

- 2.4.3.1 HybridIII 50% male dummies shall be calibrated in accordance with the provisions of CFR 572 Subpart E, Appendix 10 to ECE R94 and SAE 2779; HybridIII 5% female dummies in accordance with the provisions of CFR 572 Subpart 0 and SAE J2878.
- 2.4.3.2 The dummies shall be re-calibrated after every two impact tests. The knee sliding displacement shall be calibrated in accordance with SAE J2876 after every two tests and re-calibrated in accordance with SAE J2856 after every eight tests.
- 2.4.3.3 If an injury criterion reaches or exceeds its low limit as specified in Paragraph 2.1.2 of Chapter IV, then that part of the dummy shall be re-calibrated.
- 2.4.3.4 If any part of a dummy is broken in a test then the part shall be replaced.
- 2.4.3.5 All data concerning the calibration of dummies shall be maintained for future check.

2.5 Instrumentation

All instrumentation shall be calibrated prior to the test. All instrumentation shall be re-calibrated after one year, regardless of their use frequency. Accelerometers shall be subject to normal calibration with vibration sensor calibrators, to ensure the accuracy of test results. The Channel Amplitude Class (CAC) for each sensor shall be chosen to cover the Minimum Amplitude listed in Table 20. In order to ensure the accuracy of the test, CACs which are several times greater than the Minimum Amplitude shall not be used. A sensor shall be re-calibrated if it reaches its CAC during any test.

Table 20 Test requirements

Instrumentation	Location	Minimum amplitude	Channels measured	
Driver HybridIII 50% male dummy	Head: Accelerations	Ax, Ay, Az	250g	3
	Neck: Forces and moments	Fx	9kN	3
		My	280Nm	
		Fz	13kN	
	Thorax: Deformation and accelerations	Dchest	90mm	4
		Ax, Ay, Az	150g	
	Upper leg: Compression forces (L/R)	Fz	13kN	2
	Knees: Sliding displacements (L/R)	Dknee	19mm	2
	Upper tibia: Forces and moments (L/R)	Fz	12kN	6
Mx, My		400Nm		
Lower tibia: Forces and moments (L/R)	Fz	12kN	6	
	Mx, My	400Nm		
Front occupant HybridIII 50%male	Head: Accelerations	Ax, Ay, Az	250g	3
	Neck: forces and moments	Fx	9kN	

dummy		My	290Nm	3
		Fz	14kN	
	Thorax: Deformation and accelerations	Dchest	90mm	4
		Ax, Ay, Az	150g	
	Upper leg: Compression forces (L/R)	Fz	13kN	2
	Knees: Sliding displacements (L/R)	Dknee	19mm	2
Upper tibia: Forces and moments (L/R)	Fz	12kN	6	

Instrumentation	Location	Minimum amplitude	Channels measured	
		Mx, My	400Nm	6
	Lower tibia: Forces and moments (L/R)	Fz	12kN	
Second-row Hybrid III 5% female dummy	Head: Accelerations	Ax, Ay, Az	250g	3
	Neck: forces and moments	Fx	9kN	4
		Fy	9kN	
		Fz	14kN	
		My	290Nm	
	Thorax: Deformation	Dchest	90mm	1
	Pelvis: Accelerations	Ax, Az	250g	2
Ilium force (L/R)	Fx	9kN	2	
Safety belt tension sensor	Driver-side shoulder belt and waist belt	Fbelt	16kN	2
	Front occupant-side shoulder belt and waist belt	Fbelt	16kN	2
	Shoulder belt and waist belt of second-row female dummy	Fbelt	16kN	2
Accelerometer	B-pillar on the left side of the vehicle	Ax	250g	1
	B-pillar on the right side of the vehicle	Ax	250g	1
Total				72

2.6 Dummy placement and measurement

A HybridIII 50% male dummy shall be placed on driver's seat and front outboard occupant seat respectively, and a HybridIII 5% female dummy on the rear outboard seat behind front occupants. During the test, the restraint system shall be used. The instrumentation shall be mounted in the vehicle so that they are not likely to affect the movement of the dummies. Prior to the test, the dummy and instrumentation shall be stabilized in the temperatures as close as possible to the range of 20°C~22°C.

The vehicle shall be preconditioned in the temperatures of 20°C~22°C, to ensure the seat materials are at room temperature. If the seat has never been sat upon, a 75±10kg person or device shall sit on the seat for 1min twice to flex the cushions and back. All seat assemblies shall remain unloaded for at least 30min before the installation of the HPM machine (SAE J826).

The area of the seating position contacted by the HPM machine shall be covered by muslin of adequate size and proper material, for example, plain cotton with 18.9 yarns/cm² and density of 0.228kg/m², or knitted or nonwoven fabric with the same characteristics.

2.6.1.1 Driver and front row occupant

- 2.6.1.1.1 Place the seat and back assembly of the HPM machine on seat so that the centreplane of the seats coincides with the centreplane of the HPM machine.
- 2.6.1.1.2 Attach the foot and lower leg assemblies to the seat pan assembly, line through two "H" point sight buttons shall be parallel to the ground and perpendicular to the longitudinal centreplane of the seat, and length of lower leg and upper leg shall be adjusted to the 10% sight mark.
- 2.6.1.1.3 Both feet and lower leg assemblies shall be moved forward in such a way that the feet take up natural positions on the floor, between the operating pedals if necessary. Where possible, the distance between the left foot and the center plane of the HPM machine should be identical with the distance between the right foot and the center plane of the HPM machine. Confirm that the spirit of the HPM machine is brought to the horizontal by readjustment of the seat pan if necessary, or by adjusting the lower leg and foot assemblies towards the rear. The line passing through two "H" point sight buttons shall

be maintained perpendicular to the longitudinal center plane of the seat.

- 2.6.1.1.4 Apply lower leg and thigh weights in turn and confirm again that the HPM machine is leveled.
 - 2.6.1.1.5 Tilt the back pan forward against the stop and draw the HPM machine away from the seat-back using the T-bar, if the HPM machine tends to slide rearward, allow the HPM machine to slide rearward until the seat pan contacts the seat-back; if the HPM machine does not tend to slide rearward, then slide the HPM machine rearwards by applying a horizontal rearward force to the T-bar until the seat pan contacts the seat-back.
 - 2.6.1.1.6 Apply a $100\pm 10\text{N}$ force to the HPM machine at the intersection of the hip angle quadrant and the T-bar. The direction of force shall be maintained along the thigh bar. Then return the back pan to the seat-back. Throughout the following operation steps, prevent the HPM machine from sliding forward.
 - 2.6.1.1.7 Return the back pan to the seat-back, install the left and right buttock weights and then, alternately, torso weights at left and right sides. Confirm that the HPM machine is still maintained at level position.
 - 2.6.1.1.8 Pull the back pan upwards to vertical position, hold the T-bar and rock the HPM machine from side to side through range of 5° to each side of the vertical direction for three complete cycles to release any friction between the HPM machine and the seat. During the operation, the T-bar must be maintained at level position by applying an appropriate lateral force to the T-bar, meanwhile, ensure that no forces are applied in a vertical or fore and aft direction. Furthermore, the feet of the HPM machine are not to be restrained.
 - 2.6.1.1.9 If any movement of the feet has occurred during the rocking operation of the HPM machine, they must be repositioned: alternately, lift each of left and right foot off the floor the minimum necessary amount until no additional foot movement is obtained. During this lifting, the feet are to be free to rotate; and no forward or lateral loads are to be applied. When each foot is placed back in the down position, the heel is to be in contact with the structure designed for this.
 - 2.6.1.1.10 Holding the T-bar to prevent the HPM machine from sliding forward on the seat cushion, return the back pan to the seat-back. Inspect whether the lateral leveler is leveled, if necessary, apply a lateral force on top of back pan so that seat pan of HPM machine is maintained horizontal on seat.
 - 2.6.1.1.11 Alternately apply and release a horizontal rearward force, not to exceed 25N , to the head room probe at a height at the centre of the torso weights of HPM machine until the hip angle quadrant indicates that a stable position has been reached after force release.
 - 2.6.1.1.12 Measure and record the H-point of seat and torso angle.
- 2.6.1.2 Outer occupant at the second row**
- 2.6.1.2.1 Place the seat and back assembly of the HPM machine on seat so that the centreplane of the seats coincides with the centreplane of the HPM machine.
 - 2.6.1.2.2 Apply thigh weights but don't install lower leg, it is not required to install T-bar in case of interference with vehicle.
 - 2.6.1.2.3 Tilt the back pan forward against the stop and draw the HPM machine away from the seat-back using the T-bar, if the HPM machine tends to slide rearward, allow the HPM machine to slide rearward until the seat pan contacts the seat-back; if the HPM machine does not tend to slide rearward, then slide the HPM machine rearwards by applying a horizontal rearward force to the T-bar until the seat pan contacts the seat-back.
 - 2.6.1.2.4 Apply a $100\pm 10\text{N}$ force to the HPM machine at the intersection of the hip angle quadrant and the T-bar. The direction of force shall be maintained along the thigh bar. Then return the back pan to the seat-back. Throughout the following operation steps, prevent the HPM machine from sliding forward.

- 2.6.1.2.5 Return the back pan to the seat-back, install the left and right buttock weights and then, alternately, torso weights at left and right sides. Confirm that the HPM machine is still maintained at level position.
- 2.6.1.2.6 Pull the back pan upwards to vertical position, hold the T-bar and rock the HPM machine from side to side through range of 5° to each side of the vertical direction for three complete cycles to release any friction between the HPM machine and the seat. During the operation, the seat pan must be maintained at level position by applying an appropriate lateral force to the seat pan, meanwhile, ensure that no forces are applied in a vertical or fore and aft direction.
- 2.6.1.1.7 Holding the T-bar to prevent the HPM machine from sliding forward on the seat cushion, return the back pan to the seat-back. Inspect whether the lateral leveler is leveled, if necessary, apply a lateral force on top of back pan so that seat pan of HPM machine is maintained horizontal on seat.
- 2.6.1.2.8 Alternately apply and release a horizontal rearward force, not to exceed 25N, to the head room probe at a height at the centre of the torso weights of HPM machine until the hip angle quadrant indicates that a stable position has been reached after force release.
- 2.6.1.2.9 Measure and record the H-point of seat, torso angle and coordinate of the foremost point of seat cushion.
- 2.6.1.2.10 Calculate H-point of HybridIII 5% female dummy by the following formula, in which, X_{SCL} is the distance from H-point to the direction X of the foremost point of seat cushion, normally X_{AF05} is more forward than X_{AM50} .

$$X_{AF05,dummy} = X_{AM50,H-point\ manikin} + (93mm - 0.323 \times X_{SCL})$$

$$Z_{AF05,dummy} = Z_{AM50,H-point\ manikin} - 6mm$$

2.6.2 Dummy installation

A HybridIII 50% male dummy shall be placed on the driver's seat and the outside front occupant seat respectively, and a HybridIII 5% female dummy on the outside rear seat behind front occupants. The dummy shall not be left to sit directly on the seat for more than 2h prior to the test. If the dummy is in the vehicle for a time longer than 2h but less than 12h, then the dummy shall be sat on plywood boards placed over the seat, to eliminate excessive compression of the seat.

- 2.6.2.1 Place the dummy in the seat with the torso against the seat back, the upper arms against the seat back and the lower arms and hands against the outside of the upper leg.
- 2.6.2.2 Buckle up the safety belt across the dummy. Wearing position of safety belt shall be the natural wearing position, shoulder belt position shall be below the adjusting screw hole of dummy shoulder rotation, otherwise, adjust upper anchorage position of safety belt until compliance with conditions.
- 2.6.2.3 Apply a small rearwards force to the lower torso and a small forwards force to the upper torso to flex the upper torso forwards from the seat back. Then rock the torso left and right 4 times, going to between 14°~16° to the vertical.
- 2.6.2.4 Maintaining the small rearwards force to the lower torso, apply a small rearwards force to the upper torso to return the upper torso to the seat back.

2.6.3 HybridIII 50% male dummy positioning

Dummy positioning shall be carried out immediately before the test and the vehicle shall not be moved or shaken thereafter until the test has begun. If a test run is aborted, the dummy positioning and measurement procedure shall be repeated. If the dummy, after three attempts cannot be positioned within the tolerances below then it is to be placed as close to the tolerance limits as possible. Record this in the test details.

2.6.3.1 Head

The transverse instrumentation platform of the head shall be horizontal within 2.5°. To level the head of the test dummy in vehicles with upright seats with non-adjustable backs, the following sequences must be followed. First adjust the position of the “H” point within the limits set forth in Paragraph 2.6.3.5 to level the transverse instrumentation platform of the head of the test dummy. If the transverse instrumentation platform of the head is still not level, then adjust the pelvic angle of the test dummy within the limits provided in Paragraph 2.6.3.6. If the transverse instrumentation platform of the head is still not level, then adjust the neck bracket of the test dummy the minimum amount necessary to ensure that the transverse instrumentation platform of the head is horizontal within 2.5°.

2.6.3.2 Arms

The driver’s upper arms shall be adjacent to the torso with the centrelines as close to a vertical plane as possible. The occupant’s upper arms shall be in contact with the seat back and the sides of the torso.

2.6.3.3 Hands

The palms of the driver test dummy shall be in contact with the outer part of the steering wheel rim at the rim’s horizontal centreline. The thumbs shall be over the steering wheel rim and shall be lightly taped to the steering wheel rim so that if the hand of the test dummy is pushed upward by a force of not less than 9N and not more than 22N, the tape shall release the hand from the steering wheel rim. The palms of the occupant test dummy shall be in contact with outside of thigh. The little finger shall be in contact with the seat cushion.

2.6.3.4 Torso

In vehicles equipped with bench seats, the upper torso of the driver and occupant test dummies shall rest against the seat back. The midsagittal plane of the driver dummy shall be vertical and parallel to the vehicle’s longitudinal centreline, and pass through the centre of the steering wheel rim. The midsagittal plane of the occupant dummy shall be vertical and parallel to the vehicle’s longitudinal centreline and the same distance from the vehicle’s longitudinal centreline as the midsagittal plane of the driver dummy. In vehicles equipped with bucket seats, the upper torso of the driver and occupant test dummies shall rest against the seat back. The midsagittal plane of the driver and the occupant dummy shall be vertical and shall coincide with the longitudinal centreline of the bucket seat.

2.6.3.5 “H” point

The “H” point of the driver and occupant test dummies shall be within 13mm in the vertical dimension and 13mm in the horizontal dimension of a point 6mm below the position of the “H” point determined by using the procedures specified in Paragraph 2.6.1.1.12.

2.6.3.6 Pelvic angle

The pelvic angle measured from the horizontal on the flat surface of the gauge shall be $22.5^{\circ} \pm 2.5^{\circ}$.

2.6.3.7 Legs

The upper legs of the driver and occupant test dummies shall rest against the seat cushion to the extent permitted by placement of the feet. For the driver, the outboard knee clevis flange surfaces shall fall within the vertical plane, with the left leg residing, to the maximum extent practicable, within the longitudinal vertical plane. For the occupant, the outboard knee clevis flange surfaces shall fall within the vertical plane, with the interval between both surfaces at $270\text{mm} \pm 10\text{mm}$, and, to the maximum extent practicable, both legs shall fall within the longitudinal vertical planes respectively.

2.6.3.8 Feet

The right foot of the driver test dummy shall rest on the undepressed accelerator with the rearmost point of the heel on the floor surface in the plane of the pedal. If the foot cannot

be placed on the accelerator pedal, it shall be positioned perpendicular to the tibia and placed as far forward as possible in the direction of the centreline of the pedal with the rearmost point of the heel resting on the floor surface. The heel of the left foot shall be placed as far forward as possible and shall rest on the floorpan. The left foot shall be positioned as flat as possible on the footrest. The longitudinal centreline of the left foot shall be placed as parallel as possible to the longitudinal centreline of the vehicle.

The heels of both feet of the occupant test dummy shall be placed as far forward as possible and shall rest on the floorpan. Both feet shall be positioned as flat as possible on the toe board. The longitudinal centreline of the feet shall be placed as parallel as possible to the longitudinal centreline of the vehicle.

2.6.4 HybridIII 5% female dummy positioning

Dummy positioning shall be carried out immediately before the test and the vehicle shall not be moved or shaken thereafter until the test has begun. If a test run is aborted, the dummy positioning and measurement procedure shall be repeated. If the dummy, after three attempts cannot be positioned within the tolerances below then it is to be placed as close to the tolerance limits as possible. Record this in the test details.

2.6.4.1 Torso

In vehicles equipped with bench seats on the second row, the midsagittal plane of the HybridIII 5% female dummy shall parallel to the longitudinal centerline of the vehicle; in vehicles equipped with bucket seats on the second row, the midsagittal plane of the HybridIII 5% female dummy shall coincide with the longitudinal centreline of the bucket seat; the thigh of the dummy shall rest against the seat cushion to the extent permitted, and angle of leg and thigh is adjusted within $120^{\circ} \pm 5^{\circ}$, the horizontal distance between the the centerline of the knees is 160mm~170mm. Push rearward on the dummy's knees to force the pelvis into the seat so there is no gap between the pelvis and the seatback or until contact occurs between the back of the dummy's calves and the front of the seat cushion, with torso resting against the seat back.

2.6.4.2 Head

The transverse instrumentation platform of the head shall be horizontal, with the deviation angle to be ideally controlled within $\pm 0.5^{\circ}$. For the vehicles with adjustable seat backs of the second row, keep the position of thighs, and place the plane horizontal via adjusting backrest angle forward (or backward); for the vehicles with unadjustable seat backs of the second row, adjust the angle with regulating the lower neck bracket. If the requirement is unable to achieve, place the plane as horizontal as possible, and make record.

2.6.4.3 Pelvic angle

The pelvic angle of the HybridIII 5% female dummy measured from the horizontal on the flat surface of the gauge shall be $20^{\circ} \pm 2.5^{\circ}$. If failed, adjust the angle as close as possible to 20° , and guarantee the head sensor installation surface to adjust according to paragraph 2.6.4.2 and make record. If the head and the pelvic angle couldn't be fulfilled simultaneously, it shall preferentially guarantee the longitudinal plane angle is $0^{\circ} \pm 0.5^{\circ}$.

2.6.4.4 Legs and feet

Keep head, torso and thigh unmoved, adjust angle of legs, to place feet on the floorpan and keep the longitudinal centerline of two feet paralleled with longitudinal centerline of the vehicle as possible; if the feet are unable to reach the floorpan, keep the feet paralleled with the floorpan at the nearest position.

2.6.4.5 Arms

The HybridIII 5% female dummy's upper arms shall be in contact with the seat back and the sides of the torso.

2.6.4.6 Hands

The palms of the HybridIII 5% female dummy shall be in contact with outside of thigh. The little finger shall be in contact with the seat cushion.

2.6.4.7 “H” point

“H” point of the rear-row HybridIII 5% female dummy shall fall within a range of 13mm respectively from vertical and horizontal directions of H-point determined as per the procedure specified in 2.6.1.2.10.

2.6.5 Measurements of relative positions of dummies

The following measurements of dummy positions are to be recorded prior to the test after the dummy settling and positioning procedures have been carried out, as shown in Figure 25.

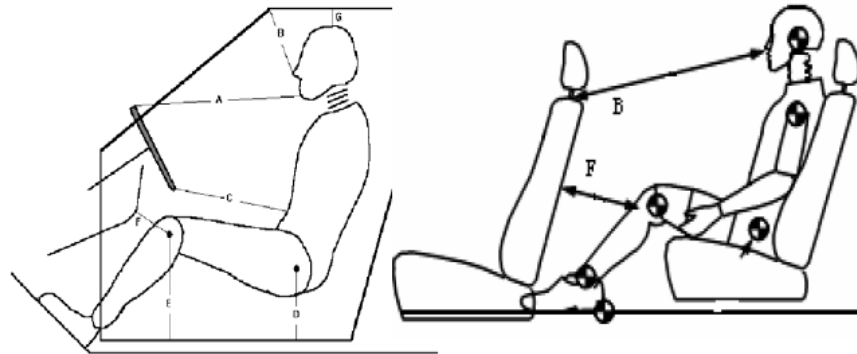

Figure 25 Schematic diagram of measurements of relative positions of dummies

Table 21 Measurements of relative positions of dummies

HybridIII 50% driver-side male dummy		HybridIII 50% front occupant side male dummy		HybridIII 5% dummy representing a female occupant behind the driver	
A	Chin to upper rim of steeringwheel	A	Chin to dashboard	A	
B	Nose to top edge of windshield glazing	B	Nose to top edge of windshield glazing	B	Nose to upper center of frontal seat back
C	Abdomen to lower rim of steering wheel	C	Abdomen to dashboard	C	
D	H-point to door sill	D	H-point to door sill	D	
E	Knee bolt to top edge of door sill	E	Knee bolt to top edge of door sill	E	
F	Knee bolt to edge of dashboard	F	Knee bolt to edge of dashboard	F	Knee joint to frontal seat back
G	Head to roof surface	G	Head to roof surface	G	Head to roof surface
H	Neck angle θ	H	Neck angle θ	H	Neck angle θ
I	H-point to vehicle structure	I	H-point to vehicle structure	I	H-point to vehicle structure
J	Actual seat back angle α	J	Actual seat back angle α	J	Actual seat back angle α

2.7 Photographs taken before and after test

The minimum resolution for photographs shall be 640×480. Given in Table 22 are the minimum quantity and contents of photographs taken before and after the test. “0” represents that photographs shall be taken.

Table 22 Test photographs

No.	View	Pre-test	Post-test
1	Front view of car	0	0
2	Front view of car LHS	0	0
3	Front view of car RHS	0	0
4	Car LHS at 45° to front	0	0
5	Car RHS at 45° to front	0	0
6	Rear view of car	0	0
7	Front view of front windshield glazing	0	0
8	To show area immediately in front of driver	0	0
9	To show area immediately in front of occupant	0	0
10	Side view of driver area	0	0
11	Side view of occupant area	0	0

12	To show driver knees	0	0
13	To show occupant knees	0	0
14	To show driver contacts		0
15	To show occupant contacts		0
16	To show the location of driver's seat	0	0
17	To show the location of occupant seats	0	0
18	Driver and car interior (with doors open)	0	0
19	Occupants and car interior (with doors open)	0	0
20	To show car with its left doors open	0	0
21	To show car with its right doors open	0	0
22	To show the front bottom of car	0	0
23	To show the rear bottom of car	0	0
24	To show area immediately on the left side of rear occupants	0	0
25	To show area immediately on the right side of rear occupants	0	0
26	To show area in front of second-row female dummy		
27	To show area at 45° to front on the left side of rear occupants	0	0
28	To show driver-side pedal area	0	0
29	To show A-pillar area on the left side of car	0	0
30	To show A-pillar area on the right side of car	0	0
31	Front view of deformable barrier	0	0
32	To show area on the left of deformable barrier	0	0
33	To show area on the right of deformable barrier	0	0
34	Deformable barrier RHS at 45° to front	0	0
35	To the position of deformable barrier relative to car		

2.8

Camera location

The minimum resolution for camera shall be 512×384. Also, the non-stroboscopic high speed film lighting system is to be used. The camera location and requirements are shown in Table 23.

Table 23 Camera location and requirements

Camera no.	Camera speed	Camera location	Shot content
1	1000fps	Front visual field of windshield glazing	Front view of motions of driver and occupant dummies
2	1000fps	Frontal end to B-pillar on the left side of car	Motion of driver dummy
3	1000fps	B-pillar to C-pillar on the left side of car	Motion of rear occupant dummy
4	1000fps	Entire visual field from barrier to left side of car	Overall motion process of the left part of car
5	1000fps	Frontal end to B-pillar on the right side of car	Motion of occupant dummy
6	1000fps	Entire visual field from barrier to right side of car	Overall view of motion of the right side of car
7	30fps	At 45° to front on the left side of car	Deformation of the left side of car
8	30fps	At 45° to rear on the left side of car	Deformation of the left side of car
9	30fps	Test track	Vehicle motion process
10	30fps	At 45° to front on the right side of car	Deformation of the right side of car
11	1000fps	Interior of rear-row occupant compartment (onboard camera)	Motion attitude of rear-row female dummy

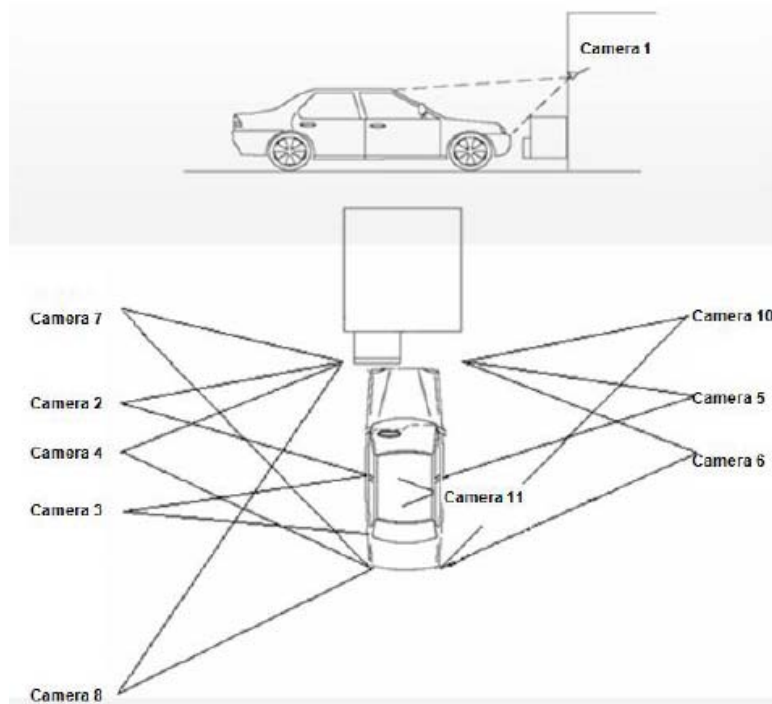

Figure 26 Camera location for frontal impact test against deformable barrier with 40% overlapping

2.9 Test facilities

2.9.1 Testing ground

The test area shall be large enough to accommodate the run-up-track, the barrier and the technical equipment necessary for the test. The track, for at least 5m before the barrier, shall be horizontal, flat, dry and smooth.

2.9.2 Traction system

The acceleration of the vehicle shall be $\leq 0.3g$, to ensure the location of the dummy before the impact. The vehicle shall be accelerated in such a way: it moves at acceleration in the first half of the run-up track and at a constant speed in the last half. The speed shall be controlled such that it is accurate to $\pm 0.2\text{km/h}$. The test speed is between $63\text{km/h} \sim 65\text{km/h}$. Record the actual test speed.

2.9.3 Lighting system

The non-stroboscopic lighting system for the high speed camera shall be actuated 5min before the test, to ensure the temperature of the impact zone is not unreasonably high.

2.9.4 Deformable barrier positioning

2.9.4.1 Measurement of vehicle width

Determine the widest point of the vehicle ignoring the rear-view mirrors, side marker lamps, tyre pressure gauge, direction indicator lamps, position lamps, flexible mud-guards and the deflected part of the tyre side-walls immediately above the point of contact with the ground. Measure and record vehicle width.

2.9.4.2 Vehicle overlapping

Determine the central bisection line of the vehicle. Calculate 10% of the vehicle width and mark a line on the bonnet and front bumper which is 10% of the vehicle width to the central bisection line. The area between this line and the widest point on the driver's side of the car will be the overlapping area with the deformable barrier.

2.9.4.3 Vehicle to deformable barrier positioning

The overlapping of the vehicle with the deformable barrier face shall be $40\% \pm 20\text{mm}$.

2.9.5 Mounting deformable barrier

2.9.5.1 The deformable barrier shall be rigidly fixed to the edge of a block of reinforced concrete weighing at least $7 \times 10^4\text{kg}$ or to some structure attached thereto. The attachment of the barrier face shall be such that the vehicle shall not come into contact with any structure at any height above 75mm from the top surface of the barrier (excluding the upper flange) during any stage of the impact. The frontface of the surface to which the deformable face is attached shall be flat and continuous over the height and width of the face and shall be vertical and perpendicular to the axis of the run-up track, with the tolerance being $\pm 1^\circ$. The attachment surface shall not be displaced by more than 10mm during any stage of the test. If necessary, additional anchorage or arresting devices shall be used to prevent displacement of the concrete block. The edge of the deformable barrier shall be aligned with the edge of the attachment surface appropriate for the side of the vehicle to be tested.

2.9.5.2 The deformable barrier shall be attached by means of ten bolts, five in the top mounting flange and five in the bottom. These bolts shall be of at least 8mm diameter. Steel clamping strips shall be used for both the top and bottom mounting flanges (see Figures 15 and 16). These strips shall be 60mm high, 1,000mm wide and 3mm thick. The edges of the clamping strips shall be rounded off to prevent tearing of the barrier against the strip during impact. The edge of the strip shall be located no more than 5mm above the base of the upper barrier mounting flange, or 5mm below the top of the lower barrier mounting flange. Five clearance holes of 9.5mm diameter shall be drilled in both strips to correspond with those in the mounting flange on the barrier. The mounting strip and barrier flange holes may be widened from 9.5mm up to a maximum of 25mm in order to accommodate differences in back-plate arrangements and/or load cell wall hole configurations. None of the fixtures shall fail in the impact test. In the case where the deformable barrier is mounted on a load cell wall (LCW) it shall be noted that the above dimensional requirements for mountings are intended as a minimum. Where a LCW is present, the mounting strips may be extended to accommodate higher mounting holes for the bolts. If the strips are required to be extended, then thicker gauge steel shall be used accordingly, such that the barrier does not pull away from the wall, bend or tear during the impact. If an alternative method of mounting the barrier is used, it shall be at least as secure as that specified in the above Paragraphs.

2.9.6 Deformable barrier specifications

2.9.6.1 Component and material specifications

The dimensions of the deformable barrier are illustrated in Figure 27. The dimensions of the individual components of the barrier are listed separately below.

2.9.6.1.1 Main body of the cell bond

Dimensions:

Height: 650mm (in direction of cells) Width: 1,000mm

Depth: 450mm (in direction of cell axes) Tolerance of above dimensions is $\pm 2.5\text{mm}$
Material: Aluminum 3003

Cell Thickness: $0.076\text{mm} \pm 15\%$

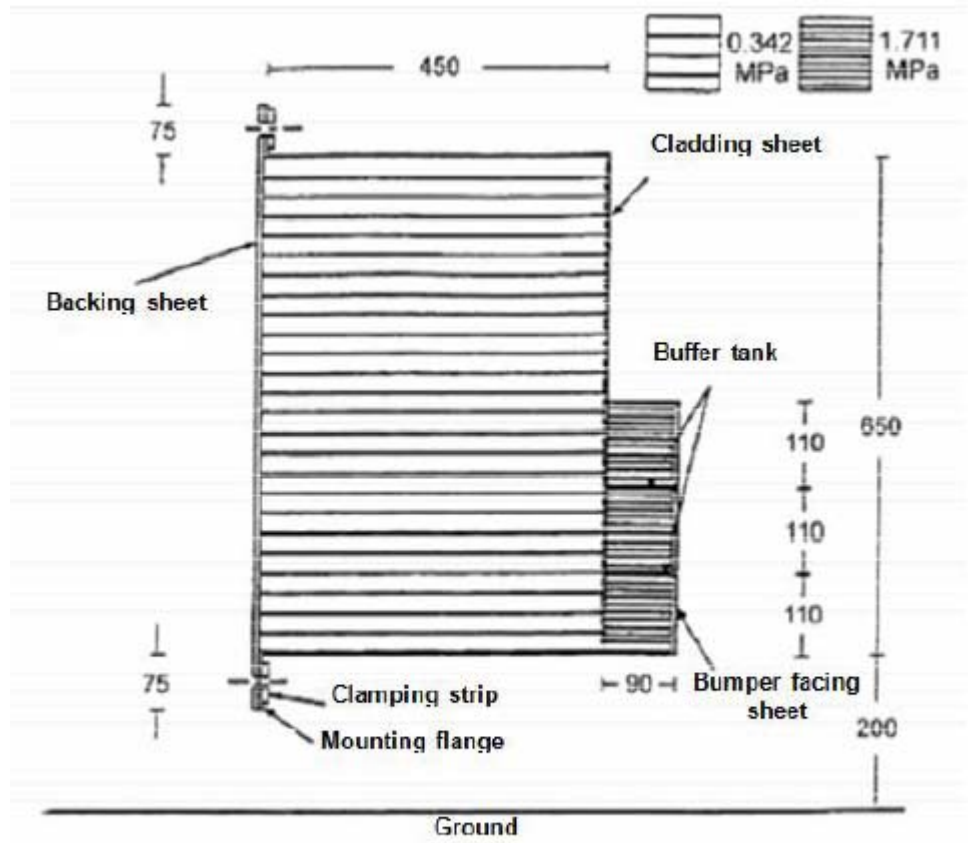

Barrier width=1,000mm
 All dimensions are expressed in mm.

Figure 27 Deformable barrier for frontal impact test against deformable barrier with 40%

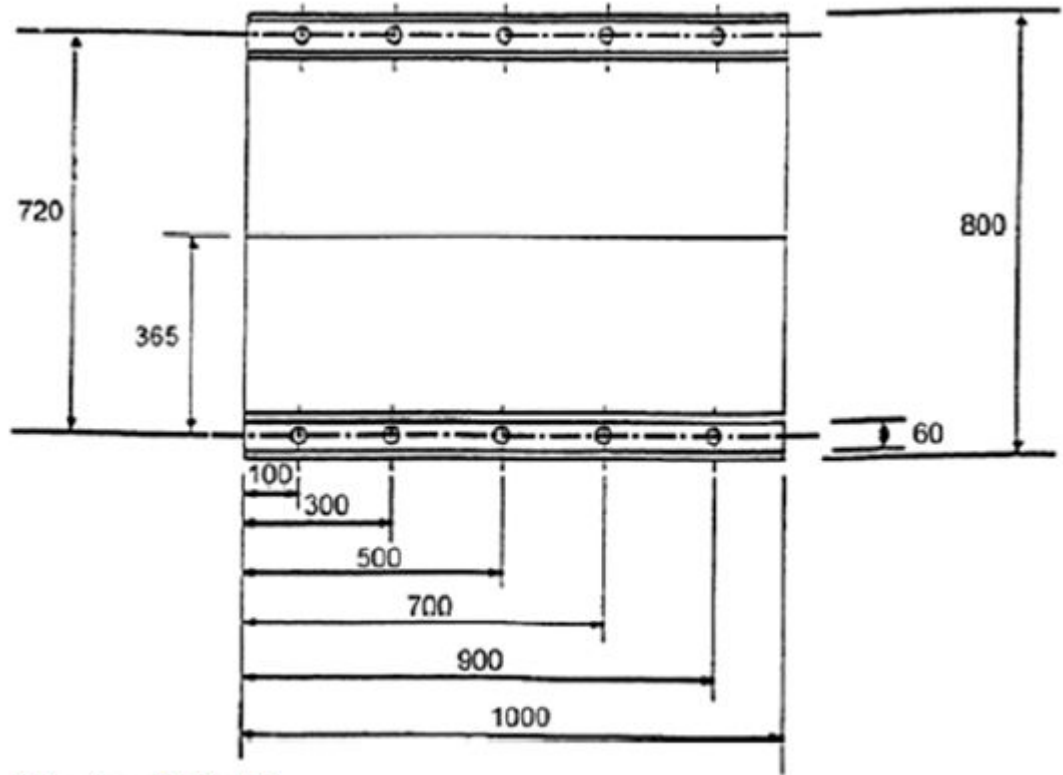

Diameter of hole: 9.5mm
All dimensions are expressed in mm.

Figure 28 Positions of holes for barrier mounting

Cell dimensions: $19.1\text{mm} \pm 20\%$

Density: $28.6\text{kg/m}^3 \pm 20\%$

Crush strength: $0.342\text{MPa} -10\% \sim 0\%$

2.9.6.1.2 **Bumper element**

Dimensions:

Height: 330mm (in direction of cells)

Width: 1,000mm

Depth: 90mm (in direction of cell axes)

Tolerance of all above dimensions is $\pm 2.5\text{mm}$

Cell Thickness: $0.076\text{mm} \pm 15\%$

Cell dimensions: $6.4\text{mm} \pm 20\%$

Density: $82.6\text{kg/m}^3 \pm 20\%$

Crush strength: $1.711\text{Mpa} -10\% \sim 0\%$

2.9.6.1.3 **Backplate**

Dimensions:

Height: $800\text{mm} \pm 2.5\text{mm}$

Width: $1,000\text{mm} \pm 2.5\text{mm}$

Thickness: $2.0\text{mm} \pm 0.1\text{mm}$

2.9.6.1.4 Cladding sheet

Dimensions:

Length: 1,700mm±2.5mm

Width: 1,000mm±2.5mm

Thickness: 0.81mm±0.07mm

Material: Aluminum 5251/5052

2.9.6.1.5 Bumper facing sheet

Dimensions:

Height: 330mm±2.5mm

Width: 1,000mm±2.5mm

Thickness: 0.81mm±0.07mm

Material: Aluminum 5251/5052

2.9.6.1.6 Adhesives

The adhesives to be used throughout shall be a two-part polyurethane (such as Ciba-Geigy XB5090/1 resin with XB5304 hardener, or equivalent).

2.9.6.2 Cell bond calibration

In the following is a briefing test procedure for calibration of the material for the deformable barrier used in frontal impact test against deformable barrier with 40%. The crush strengths applied to the material shall be 0.342MPa and 1.711MPa, respectively.

2.9.6.2.1 Sampling locations

To ensure uniformity of crush strength across the whole of the barrier face, 8 samples shall be taken from 4 locations evenly spaced across the honeycomb block. The location of the samples depends on the size of the honeycomb block. First, 4 samples, each measuring 300mm×300mm×50mm thick shall be cut from the block of barrier face material. Please refer to Figure 17 for an illustration of how to locate these sections within the honeycomb block. Each of these larger samples shall be cut into samples for certification testing (150mm×150mm×50mm). Calibration shall be based on the testing of two samples from each of these 4 locations. The other two shall be made available to the applicant, upon request.

2.9.6.2.2 Sample dimension

Samples with the following dimension shall be used for testing:

Length: 150mm±6mm

Width: 150mm±6mm

Height: 50mm±2mm

The walls of incomplete cells around the edge of the sample shall be trimmed as follows:

In the “W” direction, the fringes shall be no greater than 1.8mm (see Figure 30);

In the “L” direction, half the length of one bonded cell wall (in the cell direction) shall be left at either end of the specimen (see Figure 30).

2.9.6.2.3 Area measurement

The length of the sample shall be measured in three locations, 12.7mm from each end and in the middle, and recorded as L1, L2 and L3 (Figure 30). In the same manner, the width shall be measured and recorded as W1, W2 and W3 (Figure 30). These

measurements shall be taken on the centreline of the thickness. The crush area shall then be calculated as:

$$A = [(L1+L2+L3)/3] \times [(W1+W2+W3)/3]$$

2.9.6.2.4 Crush rate and distance

The sample shall be crushed at a rate of not less than 5.1mm/min and not more than 7.6mm/min. The minimum crush distance shall be 16.5mm.

2.9.6.2.5 Data collection

Force versus deflection data are to be collected in either analog or digital form for each sample tested. If analog data are collected then a means of converting this to digital must be available. All digital data must be collected at a rate of not less than 5Hz (5 points per second).

2.9.6.2.6 Crush strength determination

Ignore all data prior to 6.4mm of crush and after 16.5mm of crush. Divide the remaining data into three sections or displacement intervals (n=1, 2, 3) (see Figure 27), where:

- 6.4mm~9.7mm, inclusive
- 9.7mm~13.2mm, exclusive
- 13.2mm~16.5mm, inclusive

Calculate the average value for each section:

$$F(n) = (F(n)1 + F(n)2 + \dots + F(n)m) / m \quad m = 1, 2, 3$$

Where m is the number of data points in each of the displacement intervals. Calculate the crush strength as follows:

$$S(n) = F(n) / A \quad n = 1, 2, 3$$

2.9.6.2.7 Sample crush strength specification

For a cell bond sample to pass this calibration, the following condition shall be satisfied:

$0.308\text{Mpa} \leq S(n) \leq 0.342\text{Mpa}$, for 0.342Mpa material

$1.540\text{Mpa} \leq S(n) \leq 1.711\text{Mpa}$, for 1.711Mpa material, n = 1, 2, 3.

2.9.6.2.8 Block crush strength specification

Eight samples are to be tested from 4 locations, evenly spaced across the block. For a block to pass calibration, 7 of the 8 samples must meet the crush strength specification of the previous section.

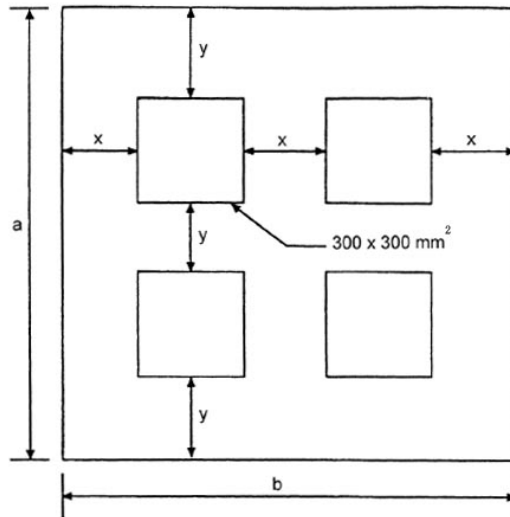

If $a \geq 900\text{mm}$: $x = 1/3 (b - 600\text{mm})$ and $y = 1/3 (a - 600\text{mm})$ (for $a \leq b$)

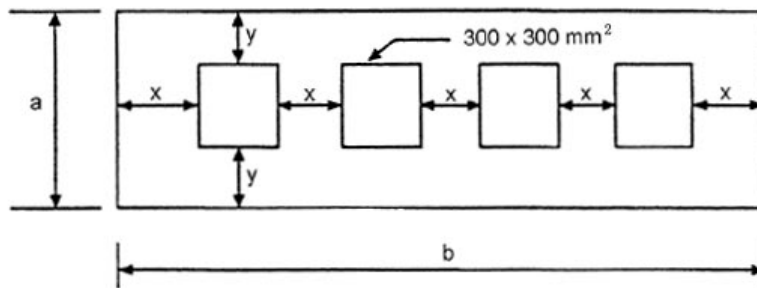

If $a < 900\text{mm}$: $x = 1/5 (b - 1,200\text{mm})$ and $y = 1/2 (a - 300\text{mm})$ (for $a \leq b$)

Figure 29 Locations of samples for calibration

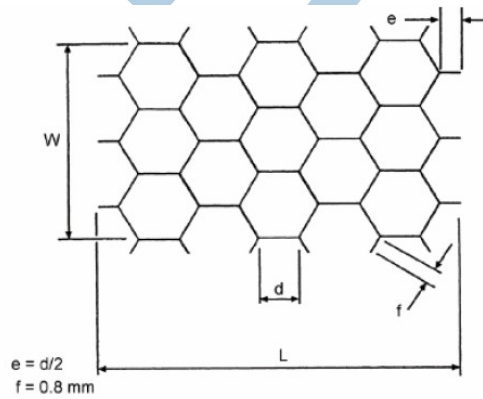

Figure 30 Cell bond axes and measured dimensions

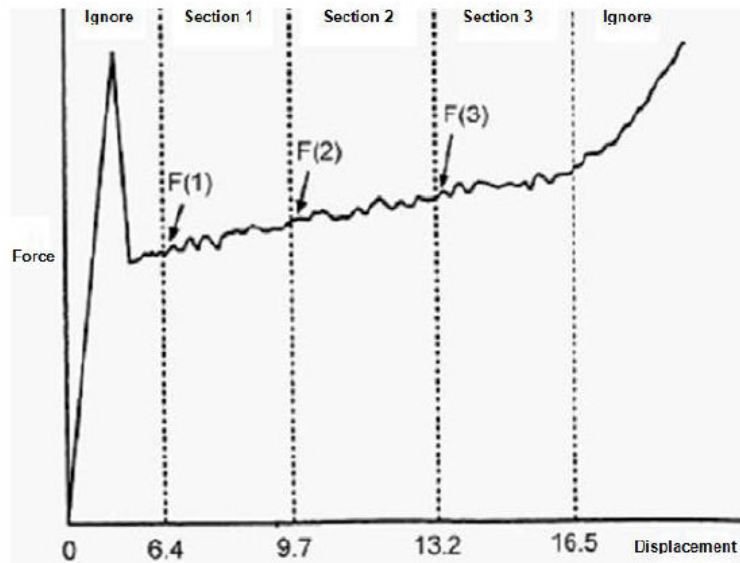

Figure 31 Compressive force and displacement

2.9.6.3 Adhesive bonding procedure

2.9.6.3.1 Immediately before bonding, aluminum sheet surfaces to be bonded shall be thoroughly cleaned using a suitable solvent. This is to be carried out at least twice or as required to eliminate grease or dirt deposits. The cleaned surfaces shall then be abraded using 120 grit abrasive paper. Metallic/Silicon Carbide abrasive paper is not to be used. The surfaces must be thoroughly abraded and the abrasive paper changed regularly during the process to avoid clogging, which may lead to a polishing effect. Following abrading, the surfaces shall be thoroughly cleaned again, as above. In total, the surfaces shall be solvent cleaned at least four times. All dust and deposits left as a result of the abrading process must be removed, as these will adversely affect bonding.

2.9.6.3.2 The adhesive shall be applied to one surface only, using a ribbed rubber roller. In cases where cell bond is to be bonded to Aluminum sheet, the adhesive shall be applied to the Aluminum sheet only. A maximum of 0.5kg/m^2 shall be applied evenly over the surface, giving a maximum film thickness of 0.5mm.

2.9.6.4 Construction

2.9.6.4.1 The main block shall be adhesively bonded to the backplate such that the cell axes are perpendicular to the sheet. The cladding sheet shall be bonded to the front surface of the block. The top and bottom surfaces of the cladding sheet shall not be bonded to the main honeycomb block but shall be positioned closely to it. The cladding sheet shall be adhesively bonded to the backplate at the mounting flanges.

2.9.6.4.2 The bumper element shall be adhesively bonded to the front of the cladding sheet such that the cell axes are perpendicular to the sheet. The bottom of the bumper element shall be flush with the bottom surface of the cladding sheet. The bumper facing sheet shall be adhesively bonded to the front of the bumper element.

2.9.6.4.3 The bumper element shall then be divided into 3 equal sections by means of two horizontal slots. These slots shall be cut through the entire depth of the bumper section and extend the whole width of the bumper. The slots shall be cut using a saw; their width shall be the width of the blade used and shall not exceed 4.0mm.

2.9.6.4.4 Clearance holes for mounting the barrier are to be drilled in the mounting flanges (shown in Figure 28). The holes shall be of 9.5mm diameter. Five holes shall be drilled in the top flange at a distance of 40mm from the top edge of the flange and five in the bottom flange, 40mm from the bottom edge of that flange. The holes shall be at 100mm, 300mm, 500mm, 700mm and 900mm from either edge of the barrier. All holes shall be drilled to $\pm 1\text{mm}$ of the nominal distances. These hole locations are a recommendation only.

Alternative positions may be used which offer at least the mounting strength and security as that provided by the above mounting specifications.

2.10 Items to be checked and confirmed before test

2.10.1 Battery

Check that whether the vehicle battery is connected, reaches rated voltage as well as is fastened securely. The battery shall be replaceable.

2.10.2 Ignition switch

The ignition switch shall be placed at "on" position.

2.10.3 Airbag warning light

The airbag switch, where fitted, shall be placed at "on" position, and the airbag light on the dashboard shall illuminate as normal.

2.10.4 Dummy painting

Colored paints shall be applied to the parts of the frontal-row dummies such as head, nose, chin, knee and lower leg, etc., to identify and tell them apart. Neck shall be painted red; nose purple; chin blue; left knee red; right knee blue; left lower leg purple, green and blue from top to bottom; right lower leg green, red and purple from top to bottom. All painted areas shall be large enough to enable the dummy's contacts with the vehicle to be visible. The frontal side of head of the rear-row female dummy shall be painted in red, the side facing the door, in green, and the other side, in yellow; in addition, nose shall be painted in brown, and chin, in blue.

2.10.5 Checking the on-board data acquisition unit

Ensure that the battery of the on-board data acquisition unit is in a normal working condition prior to the test, and measure the trigger switch at a normal working condition.

2.10.6 Checking doors and latches

Ensure that all doors are completely closed, but not locked prior to the test. For vehicle with automatic door locking function, the door should be locked to test.

2.10.7 Measurement inspection of pure electric vehicle / hybrid electric vehicles (EV/HEV)

2.10.7.1 Set the vehicle start switch to "ON" position. The vehicle shall be started, the power battery power shall be confirmed through the instrument panel, and perform reference measurement of the insulation resistance of the system before the test.

2.10.7.2 Use the IPXXB test finger to measure the direct contact protection of the system.

2.10.7.3 Use the measuring device to measure the indirect contact protection.

2.11 Items to be checked and confirmed after test

2.11.1 Safety belt

With regard to the safety belts for driver, front occupant and rear occupant dummies, check whether they fail or not during the test.

2.11.2 Doors

Inspect whether doors are locked or not. After the test, inspect whether the side doors corresponding to each row of seats can be opened without any tools.

2.11.3 Fuel feeding system

After the impact test, check whether the feeding system leaks or not. Where constant leakage occurs in the fuel feeding system, measure the amount of fuel leaked in the first 5min after the impact test. Calculate the average leaking rate.

2.11.4 Opening force of safety belt buckle

Measure and record the forces applied to open the safety belt buckles for driver, front occupant and rear occupant dummies.

2.11.5 Measurement inspection of pure electric vehicle / hybrid electric vehicle (EV/HEV)

The measurements of pure electric vehicle / hybrid electric vehicles are checked in accordance with 1.12.5 in this chapter.

2.12 Calculation of dummy injury criteria

Table 24 lists sensor CFC of all the measurement locations. Record all these channel data. Head impacts occurring after the dummy head rebounds from an initial contact are not considered when calculating injury criteria of head and neck.

Table 24 Channel frequency class (CFC) of sensor

	Location	Parameter	CFC	Calculation of injury parameters
HybridIII 50% male dummy	Head	Accelerations Ax, Ay, Az	1,000	HIC36 Resultant 3ms exceeding
	Neck	Forces Fx, Fz	1,000	Tension (Fz) continuous exceeding Shear (Fx) continuous exceeding Peak extension (My) _i
		Moments My	600	
	Thorax	Deflection Dchest	180	Peak deflection VC value Resultant 3ms exceeding
		Accelerations Ax, Ay, Az		
	Upper leg: Compression forces (L/R)	Forces Fz	600	Continuous exceeding of compressive axial force
	Knees: Sliding displacements (L/R)	Displacements Dknee	180	Peak displacement
	Upper tibia: Forces and moments (L/R)	Forces Fz	600	Peak tibia compression Tibia Index
		Moments Mx, My		
	Lower tibia: Forces and moments (L/R)	Forces Fz	600	Peak tibia compression Tibia Index
Moments Mx, My				
HybridIII 5% female dummy	Head	Accelerations Ax, Ay, Az	1,000	HIC15
	Neck	Forces Fx, Fy, Fz	1,000	Peak force of neck
		Moments My	600	Peak extension (My) _i
	Thorax	Deflection Dchest	180	Peak deflection
	Pelvis	Accelerations Ax, Az	1,000	Resultant accelerations
Iliac force Fx		180	Force unloading ratio	
Body	B- pillar	Accelerations Acc	60	Body acceleration

2.12.1 HybridIII 50% male dummy

2.12.1.1 Head

$$A_R = \sqrt{A_x^2 + A_y^2 + A_z^2}$$

$$HIC = (t_2 - t_1) \left[\frac{\int_{t_1}^{t_2} A_R \cdot dt}{(t_2 - t_1)} \right]^{2.5}$$

Where Ax, Ay, Az -- Represent accelerations in three dimensions, expressed in g, and t₂-t₁≤36ms. Calculate resultant accelerations for a cumulative time period of 3ms.

2.12.1.2 Neck

Calculate the neck extension bending moment from:

$$(My)_i = My - Fx \cdot d$$

Where My and Fx are bending moment and shearing force respectively measured at the transducer and d is the distance from the transducer to the interface (SAE J1733) d=0.01778. Determine the 'continuous exceeding' of both the neck tension (Fz) and neck shear (Fx) forces.

2.12.1.3 Thorax

Determine the peak thorax deformation and calculate VC value of thorax.

Calculate the VC value of thorax from:

$$(VC)_{(t)} = 1.3V_{(t)} \times C_{(t)}$$

$$C_{(t)} = \frac{D_{(t)}}{0.229}$$

The rib deformation rate at the time t is obtained based on the deformation which is filtered.

$$V_{(t)} = \frac{8[D_{(t+1)} - D_{(t-1)}] - [D_{(t+2)} - D_{(t-2)}]}{12\delta t}$$

Where:

$D(t)$ is the deformation at the time t (m); δt represents the interval for measurement of deflection (s).

2.12.1.4 Upper leg

Determine the axial compressive force on a continuous basis.

2.12.1.5 Knee sliding displacement

Determine the peak knee slider displacement.

2.12.1.6 Lower leg

Calculate TI :

$$M_R = \sqrt{(M_X)^2 + (M_Y)^2}$$

$$TI = |M_R / (M_C)_R| + |F_Z / (F_C)_Z|$$

Where:

M_X -- The bending moment about the x axis;

M_Y -- The bending moment about the y axis;

$(M_C)_R$ -- The critical value of the bending moment = 225Nm;

F_Z -- The axial compressive force in vertical direction (z);

$(F_C)_Z$ -- The critical value of the compressive force = 35.9kN;

The peak value of TI and the peak axial compressive force.

2.12.2 HybridIII 5% female dummy

2.12.2.1 Head

$$A_R = \sqrt{A_x^2 + A_y^2 + A_z^2}$$

$$HIC = (t_2 - t_1) \left[\frac{\int_{t_1}^{t_2} A_R \cdot dt}{(t_2 - t_1)} \right]^{2.5}$$

Where: A_x, A_y, A_z -- Acceleration values in three directions, expressed in $g, t_2-t_1 \leq 15\text{ms}$.

2.12.2.2 Neck

Calculate the neck extension bending moment from:

$$(M_y)_i = M_y - F_x \cdot d$$

Where M_y and F_x are values respectively measured at the transducer and d is the distance from the center of transducer to the head-neck interface (SAE J1733) $d=0.01778$. Determine the peak value of extensional bending moment (F_z) and shearing force (F_x) of the neck.

2.12.2.3 Thorax

Determine the peak value of compressive deformation of thorax.

2.13.2.4 Pelvis

Calculate speed of pelvis through X-direction and Y-direction resultant acceleration of pelvis, and take the instant when the relative velocity is identical with vehicle body as pelvis bouncing 0 instant.

3 Side impact test procedure

3.1 Vehicle preparation

3.1.1 Checking and confirming vehicle(s) upon arrival

When the vehicle to be tested arrives at the laboratory, the C-NCAP logo and the vehicle's unique identification - the test number and the laboratory information shall be attached to the vehicle. And measure and record the mass of the vehicle and its front and rear axle loads. Check and confirm the appearance, configuration and basic parameters of the vehicle (Appendix 3).

3.1.2 Common fuel vehicle

3.1.2.1 Measurement of kerb mass

3.1.2.1.1 Drain the fuel from the tank and then run the engine until it has run out of fuel.

3.1.2.1.2 Calculate the mass of the fuel contain in the tank at its rated capacity, using a density for petrol of 0.74g/ml or 0.84g/ml for diesel. The fuel tank shall be filled with water to mass equal to 90% of the mass of a fuel.

3.1.2.1.3 Check and adjust tyre pressure according to the manufacturer's instructions for half load. Check and top up the levels of all other fluids (e.g., engine oil, transmission fluid, brake fluid, washing fluid, antifreeze, etc.) to their maximum levels. Confirm the spare tyre and driver tool are on-board. Nothing else shall be in the vehicle.

3.1.2.1.4 Measure and record the mass of the vehicle and its front and rear axle loads. The mass of the vehicle is the kerb mass of the complete vehicle.

3.1.2.1.5 Measure and record the ride-heights of the vehicle for all four wheels at the point on the wheel arch in the same transverse plane as the wheel centers.

3.1.2.2 Measurement of reference mass

3.1.2.2.1 Adjust the front row seats at both sides to the middle position of travel or in the nearest backward locking position.

3.1.2.2.2 Place a WorldSID 50th test dummy (75kg) in the front driver's seating position or an equivalent weight.

3.1.2.2.3 Place weight in the luggage apartment, till the vehicle mass is the kerb mass plus 100kg. The weights shall be evenly distributed in the apartment. If inconvenient, they shall be

placed in the middle position of the apartment.

3.1.2.2.4 Place an SID II-s test dummy (45kg) or an equivalent weight on the impacted side seat of the second row.

3.1.2.2.5 Measure the mass of the vehicle and its front and rear axle loads, namely reference mass and reference axle load.

3.1.2.2.6 Measure and record the height of the intersection point between the transverse plan passing through the centers of the 4 wheels and the upper edge of the wheel guard plate.

3.1.2.3 Vehicle preparation and test device installation

3.1.2.3.1 Remove the luggage area carpeting, any tools supplied with the vehicle and spare tyres from the vehicle (ensure that it will not affect the crash performance of the vehicle).

3.1.2.3.2 Fix the on-board data acquisition equipment. Also install one-way accelerometers at the lower B-pillar sill on the right side of the vehicle (Y axis). A three-way accelerometers shall be mounted at the centre of weight of the mobile deformable barrier.

3.1.2.3.3 Place a WorldSID 50th test dummy (75kg) in the front driver's seating position or an equivalent weight (with the seat in the middle position).

3.1.2.3.4 Place an SID II -s test dummy (45kg) or an equivalent weight on the impacted side seat of the second row.

3.1.2.3.5 Measure the mass of the vehicle and its front and rear axle loads. Compare them with those determined in Paragraph 3.1.2.2.5. The total vehicle mass shall be within 1% of the reference mass. Each axle load shall be within the smaller of 5% or 20kg of its respective axle reference load. Any component not liable to affect the crash performance of the vehicle may be added or removed and the mass of the water in the fuel tank may be adjusted to help achieve the desired weights.

3.1.2.3.6 Measure and record the height of the intersection point between the transverse plan passing through the centers of the 4 wheels and the upper edge of the wheel guard plate.

3.1.3 Pure electric vehicle/hybrid electric vehicle (EV/HEV)

3.1.3.1 Report and registration of basic information of vehicle

Manufacturer should submit information related to high-voltage system and its assembly layout and/or position to C-NCAP Administration Center, including:

3.1.3.1.1 Layout diagram and/or photo of high voltage system and its assembly, and layout position indicating rechargeable energy storage system (REESS).

3.1.3.1.2 Explanatory drawing and written record material related to fixture method of REESS.

3.1.3.1.3 Material description related to battery type of REESS, battery capacity, electrolyte composition and its total volume, etc.

3.1.3.1.4 For vehicle featuring high voltage automatic disconnection device, if manufacturer determines to perform verification test for validity of device, then it is necessary to provide the position of automatic disconnection device of vehicle, and briefly describe its working theory or working method.

3.1.3.2 Vehicle charging

Before test, it is necessary to charge traction battery. Impact test of battery electric vehicle and plug-in hybrid electric vehicle should be performed within 24h after end of charge of vehicle.

3.1.3.2.1 For plug-in battery electric vehicle and hybrid electric vehicle, it is allowed to charge traction battery to the maximum state of charge as per the requirement of manufacturer.

3.1.3.2.2 For plug-in battery electric vehicle and hybrid electric vehicle, perform full charge of traction battery as clause 5.1 of GB/T 18385-2005 if manufacturer has no requirement.

3.1.3.2.3 For non-plug-in hybrid electric vehicle, prepare test as per the normal operating conditions of vehicle.

3.1.3.3 Measurement of kerb mass of vehicle

If vehicle is equipped with traction battery liquid cooling system, it is necessary to drain coolant after completion of charging, and replace with equivalent mass of liquid of color different from electrolyte of traction battery. For hybrid electric vehicle, it is also necessary to perform fuel treatment as per 3.1.2.1.1-3.1.2.1.2. Then proceed with measurement of kerb mass of vehicle as per 3.1.2.1.3-3.1.2.1.5.

3.1.3.4 Measurement of reference mass of vehicle

Perform measurement of reference mass of vehicle as per 3.1.2.2.

3.1.3.5 Preparation of vehicle and installation of test equipments

Proceed with preparation of vehicle and installation of test equipments as per 3.1.2.3.

3.1.3.6 Determination of measurement point of electrical safety

3.1.3.6.1 Determine the measurement point of insulation resistance at traction battery side, and measure the voltage of positive/negative poles of traction battery side and the voltage between positive/negative poles of traction battery and electric chassis.

3.1.3.6.2 Determine the measurement point of insulation resistance at power system load side, and measure the voltage of positive/negative poles of load side and the voltage between positive/negative poles of load side and electric chassis.

3.1.3.6.3 Mark the fixing position of REESS assembly of test vehicle for measurement of displacement and separation of relevant assemblies after impact.

3.2 Measurement of "R" point

The "R" point is measured with a mobile 3D measuring system. The 3D measuring system requires a coordinate system to be set up relative to a particular plane, with its axes being in the same directions of those of the vehicle coordinate system.

3.2.1 Place the HPM machine in accordance with Paragraph 3.6.1 (SAE J826).

3.2.2 Find two points on the vehicle to establish the x or y axis, which coincides with the vehicle coordinate system. Where such two points are not available on the vehicle, then the T-bar of the HPM machine serves as y axis.

3.2.3 Select 1 point as the original point of the coordinate system. This point may be defined by the manufacturer.

3.2.4 Establish a coordinate system, which is horizontally moved through the original point.

3.2.5 Measure and record the R-point coordinate. If the values measured are not within the range defined by the manufacturer, then re-measurement and recording will be required after the HPM machine is re-adjusted in accordance with Paragraph 3.6.1.

3.2.6 Measure and record coordinate position 250mm rearward from point R and take the position point as impact target point.

3.2.7 With the vehicle doors closed, find two points on the vehicle such that the X-coordinate value is consistent with the X-coordinate value of the target point, with the tolerance being $\pm 0.2\text{mm}$. Draw a line through the two points, which is the central position of impact area.

3.3 Occupant compartment adjustments

3.3.1 Adjustment of the driver's seat

3.3.1.1 Adjustment of marking

3.3.1.1.1 Mark seat cushion reference point on exterior surface of seat cushion support structure. The point is used for adjustment of longitudinal (fore-aft) and up/down position travel of adjustable seat cushion.

3.3.1.1.2 Determine seat cushion reference line through the reference point of seat cushion. The seat cushion reference line is a plane curve on exterior surface of seat cushion passing through seat cushion reference point, its projection on vehicle longitudinal median vertical plane is a straight line and forms a certain angle with horizontal plane.

3.3.1.1.3 Seat cushion reference line angle is defined as the angle of projection of seat cushion reference line on vehicle longitudinal median vertical plane in relation to horizontal plane (or horizontal reference plane)

3.3.1.2 Seat travel adjustment

3.3.1.2.1 Adjust position of seat along up/down and fore-aft directions, adjust seat cushion reference point to the uppermost and rearmost position.

3.3.1.2.2 Determine scope of seat cushion reference line angle. Adjust the seat cushion reference line angle to medium angle.

3.3.1.2.3 Adjust position of seat along up/down direction in such a way that seat cushion reference point is adjusted to the lowest position.

3.3.1.2.4 Adjust seat cushion reference point to position 20mm rearward from center of fore-aft travel or the rearward locking position that is closest to the position. And inspect to confirm that seat sliding rail system is already at completely locked position.

3.3.1.3 Seat-backs

If adjustable, the seat-backs shall be adjusted so that the resulting inclination of the torso of HPM machine reaches the design angle stated by the manufacturer or is adjusted to 23° towards the rear from the vertical.

3.3.1.4 Headrest

Where headrest height and tilt angle are adjustable, it is necessary to adjust to the central locking position.

3.3.1.5 Seat with auxiliary function

Seat lumbar support system should be adjusted to the lowest, retracted or air-drained position; seat cushion length adjustment system and leg support should be adjusted to the rearmost or retracted position; seat armrest should be at retracted position.

3.3.2 Front occupant seat adjustments

Front occupant seats shall be placed in the same position, to the maximum practicable extent, as driver's seat.

3.3.3 Adjustment of the second row of seats

3.3.3.1 The 2nd row seat featuring longitudinal adjustment shall be adjusted to mid-position of travel or the rearward locking position closest to the mid-position, inspect to confirm that seat rail system is already at the completely locked position.

3.3.3.2 For the 2nd row seat featuring up/down position adjustment, it is necessary to adjust to the position designed by manufacturer or the lowest position.

3.3.3.3 For the adjustable seat backs of the second-row seat, the seat-backs shall be adjusted to the design angle stated by the manufacturer or to 23° towards the rear from the vertical.

3.3.3.4 Lumbar support, if any, for second-row seat shall be adjusted to the position defined by the manufacturer or the completely retracted position.

- 3.3.3.5 Head-restraint of second-row seat shall be adjusted to the lowest locking position.
- 3.3.3.6 Head restraints adjustable for inclination shall be adjusted to their foremost positions.
- 3.3.3.7 If adjustable, seat orientation shall be adjusted to the forward-facing.
- 3.3.3.8 Other adjustment mechanisms shall be set to the manufacturer's design position.

3.3.4 Adjustment of the 3rd row seat

For the 3rd row seat featuring position adjustment, adjust longitudinal and up/down position of seat in accordance with the mode corresponding to determination of HPM evaluation zone in 3.3.3.

3.3.5 Steering wheel adjustments

- 3.3.5.1 If steering wheel is adjustable, adjust it to the uppermost position through relevant functions (including telescoping and tilt, etc).
- 3.3.5.2 The steering wheel shall be left free and the position on the vehicle traveling in a straight line specified by the manufacturer.

3.3.6 Adjustment of safety belt anchorages

For adjustable safety belt anchorage, the front row should be adjusted to 50th percentile occupant design position, and the 2nd row should be adjusted to 5th percentile occupant design position; if no design position is available, it is necessary to adjust to the mid-position or the fixing position upward and close to mid-position.

3.3.7 Gear-change lever

The gear-change lever shall be in the neutral position.

3.3.8 Glazing

The movable glazing of the vehicle shall be closed.

3.3.9 Pedals

The pedals shall be in their normal position of rest. The adjustable pedal should be placed in the foremost position (towards the front of the vehicle).

3.3.10 Sun-visor

The sun-visors shall be in the stowed position.

3.3.11 Rear-view mirror

The interior rear-view mirror shall be in the normal position of use.

3.3.12 Doors and lock

The doors shall be closed but not locked. For vehicles with automatic door lock function, the door should be locked to test.

3.3.13 Opening roof

If an opening or removable roof is fitted, it shall be in place and in the closed position.

3.3.14 Parking brake

Parking brakes shall be released.

3.4 Dummy preparation and calibration

During the test, place a WorldSID 50th test dummy at the area occupied by driver, and place a SID-II's side impact test dummy on the outboard side to the left of the second row of seats. Both dummies shall be clothed as per standard (WorldSID 50th dummy shall be clothed as per standard 50-80200 sleeveless garment). WorldSID 50th dummy

component performance should meet the requirements of ISO15830.

3.4.1 Ambient conditions for dummy tests

- 3.4.1.1 The dummy shall be tested at the temperature of 20.6°C~22.2°C and the humidity of 10%~70%.
- 3.4.1.2 The dummy shall be placed in specified temperatures for at least 5h prior to the calibration of the dummy, the adjustment of dummy joints and the impact test.
- 3.4.1.3 Use the WorldSID 50th dummy built-in sensor for temperature measurement, the temperature sensor should be installed on the bracket away from spine side on the first rib at non-collision side of thorax. Measure the time interval is not more than 10mins. Before the test, the interval does not exceed 5mins.

3.4.2 Adjustment of dummy joints

- 3.4.2.1 The dummy joints shall be adjusted as close as possible to the time of the test and, in any case, not more than 24h before the test.
- 3.4.2.2 All constant friction joints shall be subject to adjustment. When a force being 1g~2g is applied, the dummy limb can continue to fall.

3.4.3 Calibration of dummies

- 3.4.3.1 The WorldSID 50th dummy shall be subject to calibration in accordance with the provisions of ISO 15830 and WG5 N041, and the SID-IIs side impact test dummy subject to Section V of CFR 572.
- 3.4.3.2 The dummies shall be re-calibrated after every 4 impact tests.
- 3.4.3.3 If an injury criterion for the side impact test reaches or exceeds its lower limit as specified in Paragraph 1.2.1.3 of Chapter 3, then that part of the dummy shall be re-calibrated.
- 3.4.3.4 If any part of a dummy is broken in a test then the part shall be replaced.
- 3.4.3.5 All data concerning the calibration of dummies shall be maintained for future check.

3.5 Instrumentation

All instrumentation shall be calibrated prior to the test. All instrumentation shall be re-calibrated after one year, regardless of the number of tests for which it has been used. Accelerometers shall be subject to normal calibration with vibration sensor calibrators, to ensure the accuracy of test results. The Channel Amplitude Class (CAC) for each transducer shall be chosen to cover the Minimum Amplitude listed in Table 25. In order to ensure the accuracy of the test, CACs which are several times greater than the Minimum Amplitude shall not be used. A transducer shall be re-calibrated if it reaches its CAC during any test.

Table 25 Test requirements

Instrumentation	Location		Minimum amplitude	Channels measured
WorldSID 50th side impact dummy	Head: Accelerations	Ax, Ay, Az	250g	3
	Upper neck	Fx, Fy, Fz Mx, My, Mz	5kN,300Nm	6
	Shoulder joint	Fx, Fy, Fz	8kN	3
	Shoulder-ribs 2d IR Tracc	Disp. & Rot.	100mm	2
	Chest - Upper ribs 2d IR Tracc	Disp. & Rot.	100mm	2
	Chest - Middle ribs 2d IR Tracc	Disp. & Rot.	100mm	2
	Chest - Lower ribs 2d IR Tracc	Disp. & Rot.	100mm	2
	Chest	Temp.	30°C	1
	Abdomen - Upper ribs 2d IR Tracc	Disp. & Rot.	100mm	2
	Abdomen - Lower ribs 2d IR Tracc	Disp. & Rot.	100mm	2
	Thorax T12: Accelerations	Ax, Ay, Az	200g	3
	Pelvis	Ax, Ay, Az	200g	3
	Pelvis - pubis	Force	5kN	1

	Femoral neck (only impact side)	Fx, Fy, Fz	5kN	3
SID-11s side impact dummy	Head: Accelerations	Ax, Ay, Az	250g	3
	Shoulder-Rid	Disp.	75mm	1
	Chest-Rid	Disp.	75mm	3
	Thorax T12: Accelerations	Ax, Ay, Az	250g	3
	Abdominal displacement	Disp.	75mm	2
	Hip joint and iliac bone: resultant force	Fy	8kN	2
Accelerometer	B-pillar on the right side of the vehicle	Ay	250g	1
	Centre of mass of deformable barrier	Ax, Ay, Az	250g	3
Total				53

3.6 Dummy placement and measurement

A WorldSID 50th dummy shall be placed on driver's side. During the test, the restraint system shall be used. The instrumentation shall be mounted in the vehicle such that they are not likely to affect the fall of the dummy. Prior to the test, the dummy and instrumentation shall be stabilized in the temperatures as close as possible to the range of 20.6°C~22.2°C.

The vehicle shall be preconditioned in the temperatures of 20°C~22°C, to ensure the seat materials are at room temperature. If the seat has never been sat upon, a 75±10kg person or device shall sit on the seat for 1min twice to flex the cushions and back. All seat assemblies shall remain unloaded for at least 1h before the installation of the HPM machine (SAE J826).

The area of the seating position contacted by the HPM machine shall be covered by muslin of adequate size and proper material, for example, plain cotton with 18.9 yarns/cm² and density of 0.228kg/m², or knitted or nonwoven fabric with the same characteristics.

3.6.1.1 Driver

3.6.1.1.1 Place the seat and back assembly of the HPM machine on seat so that the centreplane of the seats coincides with the centreplane of the HPM machine.

3.6.1.1.2 Attach the foot and lower leg assemblies to the seat pan assembly, line through two "H" point sight buttons shall be parallel to the ground and perpendicular to the longitudinal centreplane of the seat, and length of lower leg and upper leg shall be adjusted to the 10% sight mark.

3.6.1.1.3 Both feet and lower leg assemblies shall be moved forward in such a way that the feet take up natural positions on the floor, between the operating pedals if necessary. Where possible, the distance between the left foot and the center plane of the HPM machine should be identical with the distance between the right foot and the center plane of the HPM machine. Confirm that the spirit of the HPM machine is brought to the horizontal by readjustment of the seat pan if necessary, or by adjusting the lower leg and foot assemblies towards the rear. The line passing through two "H" point sight buttons shall be maintained perpendicular to the longitudinal center plane of the seat.

3.6.1.1.4 Apply lower leg and thigh weights in turn and confirm again that the HPM machine is leveled.

3.6.1.1.5 Tilt the back pan forward against the stop and draw the HPM machine away from the seat-back using the T-bar, if the HPM machine tends to slide rearward, allow the HPM machine to slide rearward until the seat pan contacts the seat-back; if the HPM machine does not tend to slide rearward, then slide the HPM machine rearwards by applying a horizontal rearward force to the T-bar until the seat pan contacts the seat-back.

3.6.1.1.6 Apply a 100±10N force to the HPM machine at the intersection of the hip angle quadrant and the T-bar. The direction of force shall be maintained along the thigh bar. Then return the back pan to the seat-back. Throughout the following operation steps, prevent the HPM machine from sliding forward.

3.6.1.1.7 Return the back pan to the seat-back, install the left and right buttock weights and then, alternately, torso weights at left and right sides. Confirm that the HPM machine is still maintained at level position.

- 3.6.1.1.8 Pull the back pan upwards to vertical position, hold the T-bar and rock the HPM machine from side to side through range of 5° to each side of the vertical direction for three complete cycles to release any friction between the HPM machine and the seat. During the operation, the T-bar must be maintained at level position by applying an appropriate lateral force to the T-bar, meanwhile, ensure that no forces are applied in a vertical or fore and aft direction. Furthermore, the feet of the HPM machine are not to be restrained.
- 3.6.1.1.9 If any movement of the feet has occurred during the rocking operation of the HPM machine, they must be repositioned: alternately, lift each of left and right foot off the floor the minimum necessary amount until no additional foot movement is obtained. During this lifting, the feet are to be free to rotate; and no forward or lateral loads are to be applied. When each foot is placed back in the down position, the heel is to be in contact with the structure designed for this.
- 3.6.1.1.10 Holding the T-bar to prevent the HPM machine from sliding forward on the seat cushion, return the back pan to the seat-back. Inspect whether the lateral leveler is leveled, if necessary, apply a lateral force on top of back pan so that seat pan of HPM machine is maintained horizontal on seat.
- 3.6.1.1.11 Alternately apply and release a horizontal rearward force, not to exceed 25N, to the head room probe at a height at the centre of the torso weights of HPM machine until the hip angle quadrant indicates that a stable position has been reached after force release.
- 3.6.1.1.12 Measure and record the H-point of seat and torso angle.
- 3.6.1.2 Occupants at outer side of the 2nd row and the 3rd row**
- 3.6.1.2.1 Place the seat and back assembly of the HPM machine on seat so that the centreplane of the seats coincides with the centreplane of the HPM machine.
- 3.6.1.2.2 Apply thigh weights but don't install lower leg, it is not required to install T-bar in case of interference with vehicle.
- 3.6.1.2.3 Tilt the back pan forward against the stop and draw the HPM machine away from the seat-back using the T-bar, if the HPM machine tends to slide rearward, allow the HPM machine to slide rearward until the seat pan contacts the seat-back; if the HPM machine does not tend to slide rearward, then slide the HPM machine rearwards by applying a horizontal rearward force to the T-bar until the seat pan contacts the seat-back.
- 3.6.1.2.4 Apply a 100±10N force to the HPM machine at the intersection of the hip angle quadrant and the T-bar. The direction of force shall be maintained along the thigh bar. Then return the back pan to the seat-back. Throughout the following operation steps, prevent the HPM machine from sliding forward.
- 3.6.1.2.5 Return the back pan to the seat-back, install the left and right buttock weights and then, alternately, torso weights at left and right sides. Confirm that the HPM machine is still maintained at level position.
- 3.6.1.2.6 Pull the back pan upwards to vertical position, hold the T-bar and rock the HPM machine from side to side through range of 5° to each side of the vertical direction for three complete cycles to release any friction between the HPM machine and the seat. During the operation, the seat pan must be maintained at level position by applying an appropriate lateral force to the seat pan, meanwhile, ensure that no forces are applied in a vertical or fore and aft direction.
- 3.6.1.1.7 Holding the T-bar to prevent the HPM machine from sliding forward on the seat cushion, return the back pan to the seat-back. Inspect whether the lateral leveler is leveled, if necessary, apply a lateral force on top of back pan so that seat pan of HPM machine is maintained horizontal on seat.
- 3.6.1.2.8 Alternately apply and release a horizontal rearward force, not to exceed 25N, to the head room probe at a height at the centre of the torso weights of HPM machine until the hip angle quadrant indicates that a stable position has been reached after force release.

- 3.6.1.2.9 Measure and record the H-point of seat, torso angle and coordinate of the foremost point of seat cushion.
- 3.6.1.2.10 Calculate H-point of SID-IIs dummy by the following formula, in which, X_{SCL} is the distance from H-point to the direction X of the foremost point of seat cushion, normally X_{AF05} is more forward than X_{AM50} .

$$X_{AF05,dummy} = X_{AM50,H-point\ manikin} + (93mm - 0.323 \times X_{SCL})$$

$$Z_{AF05,dummy} = Z_{AM50, H-point\ manikin} - 6mm$$

3.6.2 Determination procedure of HPM evaluation zone

Determine the position of the H-points of dummies seated in the front row and the back row (the 2nd row or the 3rd row) by using HPM device, calculate the head CoG positions of 5% female dummy and 95% male dummy as per 2.2.2.1.1 of Chapter 3, and determine the evaluation zone.

- 3.6.2.1 Manufacturer should provide the design seat position of the 5% and 95% dummy to C-NCAP Administration Center, and submit relevant material description. If they are unable to be provided, respectively adjust seat travel position according to the foremost and rearmost locking positions on seat sliding track.
- 3.6.2.2 Record H-point position of front/rear row seats in 3.6.1.1.12 and 3.6.1.2.9.
- 3.6.2.3 In accordance with the design value or the actually measured value of the 5th percentile and 95th percentile of seat, perform calculation of horizontal travel between positions of seat.
- 3.6.2.4 Determine evaluation zone. Mark the boundary line of evaluation zone inside the impact side and outside the non-impact side of test vehicle.

3.6.3 Dummy installation

- 3.6.3.1 Respectively place a WorldSID 50th and SID-IIs side impact dummy on the driver side and the leftmost side of the 2nd row, and restrain dummy by using restraint system during test.
- 3.6.3.2 During the impact process, the measurement instrument installed on vehicle should not influence the motion of dummy. Temperature should be stabilized prior to test and should be kept in the range of 20.6°C-22.2°C as much as possible.
- 3.6.3.3 The dummy should not be left directly on the seat for exceed 2h prior to the test. If the time is exceed 2h, then the dummy should be placed on plywood boards placed on the surface of the seat, so as to avoid extreme compression and deformation of the seat, but the time should not exceed 12h.

3.6.4 WorldSID 50th dummy positioning

Dummy positioning shall be carried out immediately before the test and the vehicle shall not be moved or shaken thereafter until the test has begun. If a test run is aborted, the dummy positioning and measurement procedure shall be repeated. If the dummy, after three attempts cannot be positioned within the tolerances below then it is to be placed as close to the tolerance limits as possible. Record this in the test details.

3.6.4.1 "H" point

- 3.6.4.1.1 Using only seat controls, move the seat along fore-aft direction, and place the seat to the rearmost position to facilitate placement of the dummy.
- 3.6.4.1.2 The midsagittal plane of dummy is coincident with longitudinal vertical median plane of the seat and the upper torso of dummy rests against the seatback.
- 3.6.4.1.3 Through fore-aft and lateral rocking of dummy, adjust the pelvis rearward seat.
- 3.6.4.1.4 The pelvis is in contact with the seat cushion over the whole length of seat cushion, so

as to ensure repeatable and stable pelvis position.

3.6.4.1.5 To ensure a repeatable placement of the lower abdominal rib, make sure it is inside the pelvis flesh and not on top of it.

3.6.4.1.6 Move the seat (together with the dummy) to the position defined in 3.3.1.2. If it is impossible to adjust the seat to the test position due to dummy knee in contact with instrument board, then adjust the seat position rearwards until the knee clearance of at least 5mm is reserved, and modify the target value of H-point.

3.6.4.1.7 WorldSID 50th side impact dummy H-point should be located 20mm forward from H-point position determined as per the procedure specified in 3.6.1.1.12, with tolerance scope of ± 10 mm in vertical and horizontal directions. Correctly place dummy pelvis, so that cross line of H-point of dummy is perpendicular to vertical median plane of seat. The straight line passing through H-point of dummy should be horizontal with tolerance not exceed $\pm 2^\circ$.

3.6.4.1.8 Under precondition that thigh is not moved, place the left foot of dummy on the footrest (or floor), the right foot on accelerator pedal that is not depressed, and keep the heel on floor as forward as possible; if it is impossible to place on pedal, ensure that foot is perpendicular to lower leg, and heel in contact with floor. A 5mm clearance should be kept between knee and steering wheel protection cover (or central control console).

3.6.4.2 Head and torso

3.6.4.2.1 Adjust the dummy rib angle to ensure that the thorax tilt sensor reading (tilt sensor can be installed on thorax and abdomen of dummy, so as to help to acquire the required installation position) is within the scope of $\pm 1^\circ$ of the rib design angle specified by the manufacturer.

3.6.4.2.2 If the manufacturer has not specified relevant design requirement, when the actual seatback angle is within the scope of $23^\circ \pm 1^\circ$, adjust the dummy until the thorax tilt sensor reading is -2° (2° downwards) $\pm 1^\circ$. If the actual seatback angle is not in the above mentioned scope, then it is not required to adjust rib angle.

3.6.4.2.3 Adjust the dummy neck bracket to level the dummy head at $0^\circ \pm 1^\circ$ horizontal position (measure through head tilt sensor).

3.6.4.3 Feet

Ankle should be at stable arrangement position, and the thigh as parallel as possible to the dummy sagittal plane.

3.6.4.4 Arms

Place both arms of dummy at the first detent position downward of the most upward detent position.

3.6.4.5 Seat safety belt

Wearing position of the seatbelt should be the natural wearing position.

3.6.5 Positioning of SID-IIs side impact dummy

Dummy positioning shall be carried out immediately before the test and the vehicle shall not be moved or shaken thereafter until the test has begun. If a test run is aborted, the dummy positioning and measurement procedure shall be repeated. If the dummy, after three attempts, cannot be positioned within the tolerances below then it is to be placed as close to the tolerance limits as possible. Record this in the test details.

3.6.5.1 Torso

For a vehicle on which the second row is fitted with bench seat, the symmetrical plane of SID-IIs dummy shall parallel to the longitudinal centerline of the vehicle. For a vehicle on which the second row is fitted with parallel to the longitudinal centerline of the vehicle, the midsagittal plane of dummy shall coincide with the longitudinal vertical center plane

of the single seat concerned. Upper legs of dummy shall preferably stay contact with the seat cushion; adjust the angel between lower and upper legs to $120^{\circ}\pm 5^{\circ}$; the transverse distance between the longitudinal centerline of the dummy's knees shall be 160mm~170mm; and both upper and lower legs shall fall within a same vertical plane. Push dummy knees backwards such that there is no gap between the pelvis and the seatback or until contact occurs between the back of the dummy's calves and the front of the seat cushion; moreover, the upper torso of dummy shall preferably come into contact with the seat back.

3.6.5.2 Head

The head transverse instrumentation platform shall be horizontal, with the deviation angle to be ideally controlled within $\pm 0.5^{\circ}$. For the vehicles with adjustable seat backs of the second row, keep the position of thighs, and place the plane horizontal via adjusting backrest angle forward (or backward); for the vehicles with unadjustable seat backs of the second row, adjust the angle with regulating the lower neck bracket. If the requirement is unable to achieve, place the plane as horizontal as possible, and make record.

3.6.5.3 Pelvic angle

The pelvic angle of the SID-IIs 5% female dummy measured from the horizontal on the flat surface of the gauge shall be $20^{\circ}\pm 2.5^{\circ}$. If failed, adjust the angle as close as possible to 20° , and adjust the head transverse instrumentation platform to level according to Paragraph 3.6.5.2 and make record. If the head and the pelvic angle couldn't be fulfilled simultaneously, it shall preferentially guarantee the longitudinal plane angle to be $0^{\circ}\pm 0.5^{\circ}$.

3.6.5.4 Legs and feet

Keep head, torso and thigh unmoved, adjust angle of legs, to place feet on the floorpan and keep the longitudinal centerline of two feet paralleled with longitudinal centerline of the vehicle as possible; if the feet are unable to reach the floorpan, keep the feet paralleled with the floorpan at the nearest position.

3.6.5.5 Upper arms

The angle between the upper arms and the torso reference line of the dummy shall be $40^{\circ}\pm 5^{\circ}$.

3.6.5.6 "H" point

"H" point of the rear-row SID-IIs female dummy shall fall within a range of 13mm respectively from vertical and horizontal directions of H-point determined as per the procedure specified in 3.6.1.2.10 of this chapter.

3.6.6 Measurements of relative positions of dummies

The following measurements are to be recorded prior to the test after the dummy settling and positioning procedures have been carried out. As shown in Figure 32, the items to be measured are set out in Table 26.

Table 26 Measurements of relative positions of dummies

WorldSID 50 th side impact dummy		SID-IIs side impact test dummy	
A	Head to roof surface	A	Head to roof surface
B	Jaw to top edge of windshield glazing	B	Jaw to rear end of frontal-row seat head restraint
C	Jaw to center of steering wheel	C	-
D	Thorax to center of steering wheel (horizontal)	D	-
E	H-point to door frame (horizontal)	E	H-point to door frame (horizontal)
F	H-point to door sill (vertical)	F	H-point to door sill (vertical)
G	Knee to floor surface	G	Knee to floor surface
H	Head to side windshield glazing	H	Head to side windshield glazing
J	Shoulder to side windshield glazing	J	Shoulder to side windshield glazing
K	Elbow to door	K	Elbow to door
L	Buttocks to door	L	Buttocks to door
M	Knee to door	M	Knee to door

N	Seatbelt to door	N	Seatbelt to door
---	------------------	---	------------------

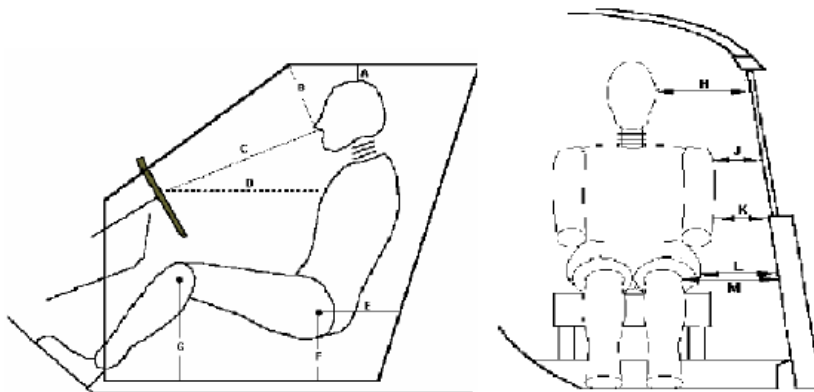

Figure 32 Schematic diagram of measurements of relative positions of dummies

3.7 Photographs taken before and after test

The minimum resolution for photographs shall be 640×480. Given in Table 27 are the minimum quantity and contents of photographs taken before and after the test. “0” represents that photographs shall be taken.

Table 27 Test photographs

No.	View	Pre-test	Post-test
1	Front view of car	0	0
2	Front view of car LHS	0	0
3	Front view of car RHS	0	0
4	Car LHS at 45° to front	0	0
5	Car RHS at 45° to rear	0	0
6	Rear view of car	0	0
7	Front view of front windshield glazing	0	0
8	To show area immediately in front of driver	0	0
9	To show area on the left side of driver	0	0
10	To show area on the right side of driver	0	0
11	To show occupant knees	0	0
12	To show driver contacts		0
13	To show the location of driver's seat	0	0
14	Driver and car interior	0	0
15	To show car with its left doors open	0	0
16	To show car with its right doors open	0	0
17	To show the front bottom of car	0	0
18	To show the rear bottom of car	0	0
19	Front view of mobile deformable barrier	0	0
20	To show the left side of mobile deformable barrier	0	0
21	To show the right side of mobile deformable barrier	0	0
22	To show area at 45° to front on the right side of mobile deformable barrier	0	0
23	To show the position of mobile deformable barrier to car		0

3.8 Camera location

The minimum resolution for camera shall be 512×384. Also, the non-stroboscopic high speed film lighting system is to be used. Camera locations and requirements are given in Figure 33 and Table 28, respectively.

Table 28 Camera locations and requirements

Camera no.	Camera speed	Camera location	Shot content
1	1000fps	Front visual field of windshield glazing	Front view of motions of driver dummy
2	1000fps	At 45° to front on the right side of dummy	View of motions of driver dummy
3	1000fps	Entire front visual field of car	View of motions of car
4	1000fps	Partial front view of car	View of motions of car and mobile deformable barrier
5	1000fps	Rear view of car	View of motions of car and mobile deformable barrier
6	1000fps	At 45° to front on the left side of car	Overall motion process of car

7	30fps	At 45° to rear on the left side of car	Overall motion process of car
8	30fps	At 45° to front on the right side of car	Overall motion process of car
9	1000fps	Visual field of deployment area of curtain airbag on impact side of vehicle.	Curtain airbag deployed, front/rear row dummy movement
10	1000fps	Local deployment area of curtain airbag on impact side of vehicle.	Curtain airbag deployed, front dummy movement
11	1000fps	Local deployment area of curtain airbag on impact side of vehicle.	Curtain airbag deployed, rear dummy movement

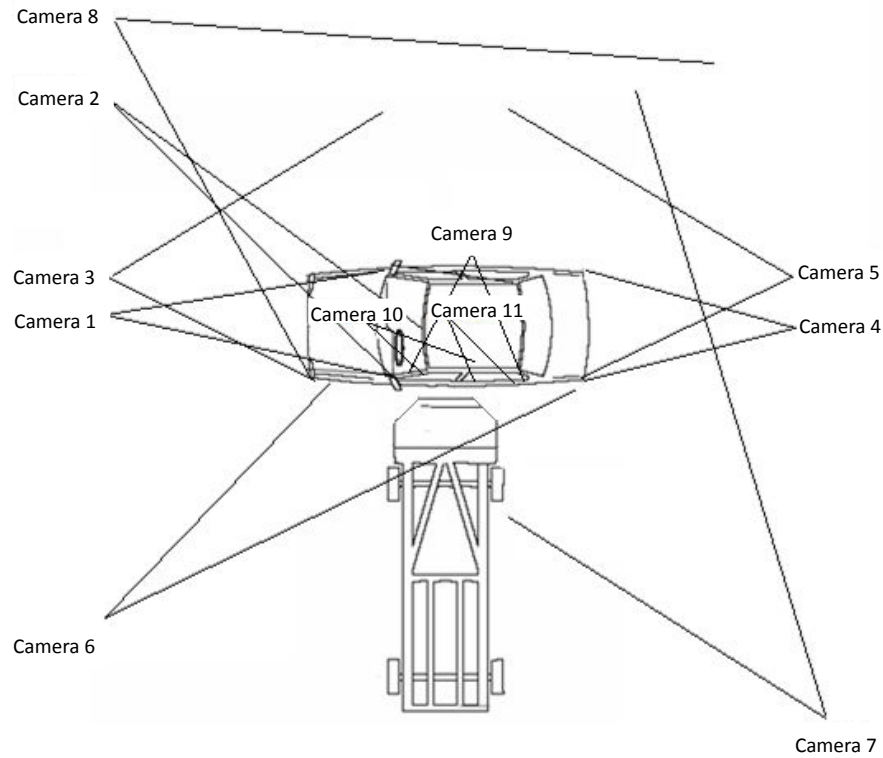

Figure 33 Camera locations for side impact test against mobile deformable barrier

3.9 Test facilities

3.9.1 Testing ground

The test area shall be large enough to accommodate the test track, the mobile deformable barrier propulsion system and the technical equipment necessary for the test and to permit after-impact displacement of the vehicle. The part in which vehicle impact and displacement occur shall be horizontal, flat, dry and uncontaminated.

3.9.2 Test speed

The test speed for the mobile deformable barrier shall be 50km/h~51km/h, and shall be stabilized at least 1m before the impact. It shall be accurate to ± 0.2 km/h. Record the actual impact speed of the mobile deformable barrier.

3.9.3 Lighting system

The non-stroboscopic lighting system for the high speed camera shall be actuated 5min before the test, to ensure the temperature of the impact zone is not unreasonably high.

3.9.4 Mobile deformable barrier to vehicle positioning

The longitudinal vertical median plane of the mobile deformable barrier shall be coincident within ± 25 mm with a transverse vertical plane passing through the R-point of the front seat adjacent to the struck side of the tested vehicle. The horizontal median

plane limited by the external lateral vertical planes of the front face shall be at the moment of impact within two planes determined before the test and situated 25mm above and below the previously defined plane.

3.9.5 Mobile deformable barrier

Mobile deformable barrier includes trolley and impact block. Advanced European mobile deformable barrier is installed on front end of trolley, relevant performance and ventilation framework should be in compliance with the stipulations of technical bulletin 014 of E-NCAP. The mobile deformable barrier shall be fitted with a braking device, to avoid its second impact with the test vehicle. C-NCAP marking shall be attached to the both sides of the mobile deformable barrier. Measure and record the mass of the mobile deformable barrier and each axle load.

- 3.9.5.1 The total mass should be 1,400kg±20kg.
- 3.9.5.2 The center of gravity should be situated at a position in the longitudinal median vertical plane ±10mm, 1,000mm±30mm behind the front axle and 500mm-0/+30mm above the ground.
- 3.9.5.3 The distance between the front face of the impact block and the center of gravity of the trolley should be 2,000mm±30mm; width should be 1700mm±2.5mm.
- 3.9.5.4 The height of the barrier should meet the following static measurement requirements prior to impact: the uppermost part of the front face of the beam unit (the intersection between the upward and downward travel of energy absorption blocks) is 600mm±5mm above ground level.
- 3.9.5.5 The front and rear track width of the trolley shall be 1500 ± 10mm.
- 3.9.5.6 The wheelbase of the trolley should be 3,000mm±10mm.
- 3.9.5.7 Inflate all tyres of the trolley to the same tyre pressure.
- 3.9.5.8 Mark a line along the vertical center of the barrier, which can be used to check the deviation of the position of impact between the barrier and the test vehicle.

3.10 Items to be checked and confirmed before test

3.10.1 Battery

Check that whether the vehicle battery is connected, reaches rated voltage as well as is fastened securely. The battery shall be replaceable.

3.10.2 Ignition switch

The ignition switch shall be placed at “on” position.

3.10.3 Airbag warning light

The airbag switch, where fitted, shall be placed at “on” position, and the airbag light on the dashboard shall illuminate as normal.

3.10.4 Dummy painting

All positions of dummy should be painted with pigment for discrimination and differentiation. Head should be painted red in circle area taking CoG as circle center and radius as 60mm, shoulder/arm should be blue, the 2nd thorax rib should be green, the 3rd thorax rib should be red, the 1st abdomen rib should be blue, the 2nd abdomen rib should be green and pelvis should be orange. All painted areas shall be large enough to enable the dummy's contacts with the vehicle to be visible.

3.10.5 Checking the on-board data acquisition unit

Ensure that the battery of the on-board data acquisition unit is in normal working condition prior to the test, and measure the trigger switch at normal working condition.

3.10.6 Checking doors and latches

Ensure that all doors are completely closed, but not locked prior to the test. For vehicle with automatic locking system function, all doors should be locked to test.

3.10.7 Measurement inspection of pure electric vehicle/hybrid electric vehicle (EV/HEV)

3.10.7.1 Turn startup switch of vehicle to “ON” position, put vehicle under startup condition, check traction battery capacity through instrument board, and perform system insulation resistance reference measurement prior to test.

3.10.7.2 Measure the direct contact protection situation of system by using IPXXB test finger.

3.10.7.3 Measure indirect contact protection situation by using measurement equipment.

3.11 Items to be checked and confirmed after test

3.11.1 Side airbag and curtain airbag

3.11.1.1 Confirm deployment mode and dynamic protection performance through high-speed video and pigment mark on the curtain airbag.

3.11.1.2 Deploy side airbag and curtain airbag of the non-impact side, and perform relevant inspection and determination, confirm whether side airbags and curtain airbags at two sides are completely symmetrical.

3.11.1.3 Inflate curtain airbag according to the pressure recommended by manufacturer or 0.3bar-0.4bar.

3.11.1.4 Project the head evaluation zone of front row and back row seats to the deployed curtain airbag as per the border line marked according to 3.6.2.4.

3.11.1.5 Perform inspection and determination of relevant dimension of evaluation zone and stitching line zone.

3.11.2 Safety belt

Check whether the collision-side dummy safety belt is liable to fail or not during the test.

3.11.3 Doors and lock

Inspect whether each door opening occurs or not during the impact. Inspect whether the vehicle door at non-impact side can be opened or not after impact test.

3.11.4 Safety belt buckle opening force

Measure the safety belt buckle opening force used for dummy at collision side and record the results.

3.11.5 Fuel system

After the impact test, check whether the feeding system leaks or not. Where constant leakage occurs in the fuel feeding system, measure the amount of fuel leaked in the first 5min after the impact test. Calculate the average leaking rate.

3.11.6 Measurement inspection of electric vehicle/hybrid electric vehicle (EV/HEV)

Relevant measurement check contents of battery electric vehicle/hybrid electric vehicle are identical with 1.12.5 in this chapter.

3.12 Calculation of injury criteria

Table 29 lists all locations of the WorldSID 50th dummy and parameters to be measured as well as the channel frequency class (CFC) at which they are to be filtered. Record all these channel data. Head impacts occurring after the dummy head rebounds from an initial contact are not considered when calculating injury criteria of head and neck. Some of the following parameters measured are to be recorded only but not for assessment. The specific parameters for evaluation are prescribed in Paragraph 1.2.1.3 of Chapter 3.

See the reference axes system used for determination of rotation angle for calculation of rib lateral displacement as per H version of W50-9900 WorldSID 50th dummy use manual.

Table 29 WorldSID 50th and SID-IIs dummy test locations and parameters to be measured

Measuring position	Measurement parameters	CFC Filter frequency class CFC	Injury index calculation
Head	Acceleration, Ax, Ay and Az	1,000	HIC ₁₅ Accumulative 3ms acceleration peak value
Neck	Force Fx, Fy and Fz	1,000	Peak value of force and torque
	Torque Mx, My and Mz	600	
Shoulder	Force Fx, Fy and Fz	600	Peak value of lateral force
	Displacement, D	180	Peak value of lateral displacement
	Rotation, α	180	Viscosity index
Thorax	Displacement, D	180	Peak value of lateral displacement
	Rotation, α	180	Viscosity index
Abdomen	Displacement, D	180	Peak value of lateral displacement
	Rotation, α	180	Viscosity index
T12	Acceleration, Ax, Ay and Az	180	Peak value of resultant acceleration
Pelvis	Acceleration, Ax, Ay and Az	600	Peak value of acceleration
	Force, Fy	600	Peak force
Hip joint and iliac bone force	Force, Fy	600	Peak value of resultant force
Neck of femur	Force, Fx, Fy and Fz	600	Peak force

3.12.1 WorldSID 50th dummy

3.12.1.1 Head

$$A_R = \sqrt{A_x^2 + A_y^2 + A_z^2}$$

$$HIC = (t_2 - t_1) \left[\frac{\int_{t_1}^{t_2} A_R \cdot dt}{(t_2 - t_1)} \right]^{2.5}$$

Where Ax, Ay, Az-- Represent accelerations in three dimensions, expressed in g; for WorldSID 50th, $t_2 - t_1 \leq 15\text{ms}$, and calculate resultant accelerations for a cumulative time period of 3ms.

3.12.1.2 Shoulder

3.12.1.2.1 Lateral shoulder force

Calculate lateral shoulder force as per the following formula:

$$F_{y_{\text{shoulder}}} = \max(F_y(t))$$

3.12.1.2.2 Lateral shoulder rib displacement

Calculate lateral shoulder rib displacement as per the following formula:

$$D_{y_{\text{shoulder}}} = \max(D_y(t) - D_y(0))$$

In the formula: $D_y(t) = R(t) \cdot \sin(\Phi_{IRT}(t))$, R (t) is the length after filtering of shoulder IR-TRACC; $\Phi_{IRT}(t)$ is rotation angle after filtering of shoulder IR-TRACC; $D_y(0)$ is lateral shoulder rib displacement at moment $t=0$.

3.12.1.3 Thorax

3.12.1.3.1 Thorax displacement

Calculate thorax displacement as per the following formula:

$$D_{\text{thorax}} = \max(D_{\text{thorax}}(t))$$

Calculate lateral thorax rib displacement as per the following formula:

$$Dy_{thorax} = \max(Dy(t) - Dy(0))$$

In the formula: $Dy(t) = R(t) \cdot \sin(\Phi(t))$, $R(t)$ is the length after filtering of thorax IR-TRACC; $\Phi(t)$ is rotation angle after filtering of shoulder IR-TRACC; $Dy(0)$ is lateral thorax rib displacement at moment $t=0$.

3.12.1.3.2 Viscosity index

Calculate value VC as per the following formula:

$$VC = V(t) \times C(t)$$

$$V(t) = \frac{8[D_{(t+1)} - D_{(t-1)}] - [D_{(t+2)} - D_{(t-2)}]}{12\delta t}, \quad C(t) = \frac{D(t)}{0.17}$$

$D(t)$ is the deformation (m) at moment t , and is the lateral thorax rib displacement Dy_{thorax} after filter calculation, δt is time interval (s) of deformation measurement.

3.12.1.4 Abdomen

3.12.1.4.1 Abdomen displacement

Calculate abdomen displacement as per the following formula:

$$D_{abdomen} = \max(D_{abdomen}(t))$$

Calculate lateral abdomen rib displacement as per the following formula:

$$Dy_{abdomen} = \max(Dy(t) - Dy(0))$$

In the formula: $Dy(t) = R(t) \cdot \sin(\Phi(t))$, $R(t)$ is the length after filtering of abdomen IR-TRACC; $\Phi(t)$ is rotation angle after filtering of abdomen IR-TRACC; $Dy(0)$ is lateral abdomen rib displacement at moment 0.

3.12.1.4.2 Viscosity index

Calculate value VC as per the following formula:

$$VC = V(t) \times C(t)$$

$$V(t) = \frac{8[D_{(t+1)} - D_{(t-1)}] - [D_{(t+2)} - D_{(t-2)}]}{12\delta t}, \quad C(t) = \frac{D(t)}{0.17}$$

In which:

$D(t)$ is the deformation (m) at moment t , and is the lateral abdomen rib displacement $Dy_{abdomen}$ after filter calculation; δt is time interval (s) of deformation measurement.

3.12.1.5 Pelvis

Take the peak pubis force.

3.12.2 SID-IIs dummy

3.12.2.1 Head

$$A_R = \sqrt{A_x^2 + A_y^2 + A_z^2}$$

$$HIC = (t_2 - t_1) \left[\frac{\int_{t_1}^{t_2} A_R \cdot dt}{(t_2 - t_1)} \right]^{2.5}$$

Where: A_x , A_y and A_z -- Post-filtering accelerations in three directions, expressed in g, and $t_2 - t_1 \leq 15$ ms.

3.12.2.2 Thorax

Take the three ribs deformation value and the maximum value of VC. The calculation of thorax VC is given in chapter 3.12.1.3.2, in which:

$$C_{(t)} = \frac{D_{(t)}}{0.138}$$

3.12.2.3 Abdomen

Take the two ribs of the abdomen and the maximum value of VC. The calculation of abdominal VC values is given in Chapter 3.12.1.4.2, in which:

$$C_{(t)} = \frac{D_{(t)}}{0.138}$$

3.12.2.4 Resultant pelvis force

Calculate the synthetic force of hip joint and iliac bone.

4 Whiplash test procedures

4.1 Sample preparations

4.1.1 The seat for the whiplash test is purchased by C-NCAP Management Center from the vehicle dealer and shall be dismantled from physical vehicle on site.

4.1.2 After samples reach the lab, it is to check and verify sample appearance, model and basic parameters, in addition to taking photos.

4.1.3 Test fixtures for seats shall be fabricated according to seat installation parameters and sample size, so as to ensure that seats could be firmly fixed to the sled and the seat status onboard the physical vehicle could be simulated.

4.2 Pre-test measurements

For the purpose of all measurements stated below, vehicles shall be conditioned to the standard state as per appropriate provisions of the C-NCAP Management Regulation (for details, see Clause 1.1, Chapter 4).

4.2.1 The relative height of the heels should be recorded by 3-D coordinate measuring machine before the C-NCAP test.

4.2.2 Determination of heel rest point

4.2.2.1 Determine and mark the geometric center point on the upper surface of accelerator pedal.

4.2.2.2 Heel rest point is defined as the intersection between a line tangential to such center point and the floor surface within the longitudinal plane.

4.3 Setting of test conditions

4.3.1 Seat preparations and mounting

Seat together with its fixtures shall be correctly fastened to the test sled platform. In the case of a brand-new seat which is never sat on, it shall be sat on twice by a person weighing 75kg±10kg or by an equivalent device, with each run lasting 1min. Prior to the placement of the HPM machine (SAEJ826), all seat assemblies shall remain unladen for 30min to the minimum.

4.3.2 Mounting of pedal

4.3.2.1 The standard pedals will be used in the test, of which the floor section is horizontal, the foot-resting section inclines by 45°, and the surface is covered by carpet.

4.3.2.2 Mount a standard toe board, and, according to the relative height of heel rest point in physical vehicle, adjust the height of the standard toe board.

4.3.3 Mounting of safety belt

4.3.3.1 Mount safety belt. During test, the dummy shall put up safety belt, so as to be prevented from being thrown away upon impact.

4.3.3.2 Safety belt anchorages, buckle, guide mechanism, etc. fitted to the test seat may be used.

4.3.4 Determination of triggering moment of active elements

4.3.4.1 Based on the data furnished by manufacturer, determine whether active element is equipped in testing seat (e.g., triggering-type proactive head restraint).

4.3.4.2 For each element requiring activation, vehicle manufacturer shall indicate the accurate triggering moment.

4.4 Test waveforms

In the range of 0ms~170ms, acceleration waveform shall be controlled in precision, so as to meet the test requirements. Speed variation of accelerating sled shall be controlled within $\Delta V=20.00\text{km/h}\pm 1.0\text{km/h}$, with the retention time of waveform within $\Delta T=103\text{ms}\pm 3\text{ms}$ (see Figure 34).

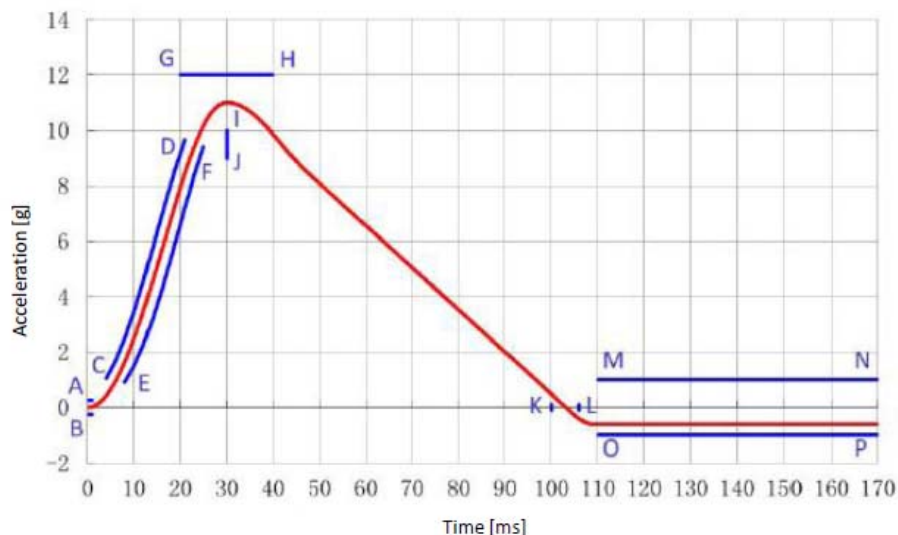

Figure 34 Acceleration waveform of whiplash test

Table 30 Parameters of test waveform channel

	Time (ms)	Acceleration (g)	Upper limit of rising edge		Lower limit of rising edge	
			Time (ms)	Acceleration (g)	Time (ms)	Acceleration (g)
A	0	0.25	(C)4	1.0395	(E)8	0.8988
B	0	-0.25				
C	4	1.0395	5	1.3381	9	1.1774
D	21	9.6553	6	1.6772	10	1.4951
E	8	0.8988	7	2.0581	11	1.8541
F	25	9.4119	8	2.4809	12	2.2551
G	20	12.00	9	2.9441	13	2.6975
H	40	12.00	10	3.4449	14	3.1791
I	30	9.00	11	3.9792	15	3.6965
J	30	10.00	12	4.5418	16	4.2450
K	100	0.00	13	5.1264	17	4.8190
L	106	0.00	14	5.7259	18	5.4117
M	110	1.00	15	6.3324	19	6.0155
N	170	1.00	16	6.9377	20	6.6225
O	110	-1.00	17	7.5333	21	7.2242
P	170	-1.00	18	8.1106	22	7.8121
			19	8.6615	23	8.3778
			20	9.1786	24	8.9134
			(D)21	9.6553	(F)25	9.4119

4.5 Test environment

Test chamber shall present a temperature of $22.5^{\circ}\text{C}\pm 3^{\circ}\text{C}$ and relative humidity of 10%~70%.

4.6 Seat adjustments

4.6.1 Initialization of seat adjustments

- 4.6.1.1 Seat track adjusted to the most rearward locking position.
- 4.6.1.2 Seat height adjusted to the lowest position.
- 4.6.1.3 Seat tilt adjusted to the position closest to the horizontal.
- 4.6.1.4 Cushion height adjusted to the lowest position.
- 4.6.1.5 Cushion tilt adjusted to the position closest to the horizontal.
- 4.6.1.6 Lumbar support adjusted to the most downward and most rearward position.
- 4.6.1.7 If seat back is separately adjustable, its upper half shall be adjusted to the rearward position.
- 4.6.1.8 Cushion extension, if adjustable, shall be adjusted to the most rearward or completely extended position.
- 4.6.1.9 Side bolsters, if adjustable, shall be adjusted to the widest or fully extended position.
- 4.6.1.10 Arm rests adjusted to the stowed position.
- 4.6.2 If longitudinal adjustable, test seat shall be adjusted to the mid position.
 - 4.6.2.1 In the case of incrementally adjustable seat, if no locking position exists within the center $\pm 2\text{mm}$, it shall be adjusted rearwards to a locking position closest to the midpoint.
 - 4.6.2.2 In the case of continuously adjustable seat, it shall be adjusted to the middle position ($\pm 2\text{mm}$).
- 4.6.3 In the case of being vertically separately adjustable, test seat shall be adjusted to the middle position.
 - 4.6.3.1 In the case of an incrementally adjustable seat by a single control, rear end of seat shall be adjusted to the middle position; if the middle position ($\pm 2\text{mm}$) is not the locking position, it shall be adjusted downwards to a locking position closest to the midpoint.
 - 4.6.3.2 In the case of a continuously adjustable seat by a single control, rear end of seat shall be adjusted to the middle position ($\pm 2\text{mm}$) in height.
 - 4.6.3.3 In the case of a by-stage, incrementally adjustable seat by dual controls, both frontal and rear ends of seat shall be adjusted to the middle position ($\pm 2\text{mm}$); if the middle position is other than a locking position, it shall be adjusted downwards to a locking position closest to the midpoint.
 - 4.6.3.4 In the case of a by-stage, continuously adjustable seat by dual controls, both frontal and rear ends of seat shall be adjusted to the middle position ($\pm 2\text{mm}$) in height.
- 4.6.4 If separately adjustable in vertical direction, test seat cushion shall be adjusted to the middle position.
 - 4.6.4.1 Measuring cushion reference angle: Adjust the cushion to its lowest height. On its frontal and rear ends, mark two points spaced by 400mm. measure the angle of the line connecting both points, which is deemed as the cushion reference angle.
 - 4.6.4.2 In the case of a by-stage adjustable seat by a single control, the rear mark point of cushion shall be adjusted to the middle position in height; if the middle position ($\pm 2\text{mm}$) is other than a locking position, it shall be adjusted downwards to a locking position closest to the midpoint.

- 4.6.4.3 In the case of a continuously adjustable seat by a single control, the rear mark point of cushion shall be adjusted to the middle position ($\pm 2\text{mm}$) in height.
- 4.6.4.4 In the case of a by-stage, incrementally adjustable seat by dual controls, the rear mark point of cushion shall be adjusted to the middle position ($\pm 2\text{mm}$) in height; if the middle position is other than a locking position, it shall be adjusted downwards to a locking position closest to the midpoint; the frontal mark point of cushion shall be adjusted such that the cushion angle runs consistent ($\pm 0.5^\circ$) with the cushion reference angle measured in Paragraph 4.6.4.1; if no locking position exists within the range of $\pm 0.5^\circ$, it shall be adjusted downwards to a closest locking position.
- 4.6.4.5 In the case of a by-stage, continuously adjustable seat by dual controls, rear end of cushion shall be adjusted to the middle position ($\pm 2\text{mm}$) in height, and the frontal mark point of cushion shall be adjusted such that the cushion angle runs consistent ($\pm 0.5^\circ$) with the cushion reference angle measured in Paragraph 4.6.4.1.
- 4.6.5 Adjustment of backrest angle**
- 4.6.5.1 If the test seat back angle is by-stage adjustable, and the angle of the upper half is separately adjustable, then the angle of the upper half shall be adjusted to the middle position ($\pm 0.5^\circ$) within the adjustable range.
- 4.6.5.2 Adjust the seat back angle (including angular adjustment for the lower half of by-stage adjustable seat back) to make sure the torso angle of the HPM machine reaches $25^\circ \pm 1^\circ$.
- 4.6.5.3 As for some incrementally adjustable seat backs, if the seat cannot be adjusted to the prescribed range, then it shall be adjusted forwards to a position closest to the target value.
- 4.6.6 Adjustment of head rest**
- 4.6.6.1 Height adjustment of head rest**
- 4.6.6.1.1 If adjustable, the height of head rest of test seat shall be adjusted to the middle position, i.e., the midway between the lowest position and the highest locking position.
- 4.6.6.1.2 If there is no locking position in the middle section, head rest shall be uplifted by 10mm from the middle position. Head rest shall be adjusted to the locking position within this travel stroke, if any.
- 4.6.6.1.3 If there is no locking position within such travel stroke of 10mm, the head rest shall be adjusted downwards to the nearest locking position.
- 4.6.6.2 Tilt adjustment of head rest**
- 4.6.6.2.1 Foremost position of head rest is defined as the locking position presenting the minimum backset (i.e., the gap between the back surface of head to the frontal surface of head restraint) as measured by HRMD (head rest measuring device). After HRMD is properly installed, adjust the head rest forwards; if the head rest already comes into contact with HRMD before the extreme position of head rest is reached, then it is unnecessary to adjust the head rest forwards any more. Also, adjust the head rest backwards to the nearest locking position, which is taken as the foremost position.
- 4.6.6.2.2 Rearmost position of head rest is defined as the position presenting the largest backset as measured by HRMD.
- 4.6.6.2.3 Adjust the tilt of head rest such that the backset measured by HRMD falls at the midway between the foremost and rearmost positions. If there is no locking position at the midway, head rest shall be adjusted to the locking position within the range 10mm forwards. If there is still no locking position, head rest shall be adjusted backwards to the nearest locking position.
- 4.6.7 For other adjustable mechanisms of test seat, the initial settings of Paragraph 4.6.1 shall be retained.
- 4.7 Determination procedures for H-point and backset**

- 4.7.1 In the case of a brand-new seat which is never sat on, it shall be sat on twice by a person weighing $75\text{kg}\pm 10\text{kg}$, with each run lasting 1min, so as to flex both seat cushion and seat back.
- 4.7.2 Prior to the mounting of H-point machine, seat shall be soaked in the standard test environment for more than 3h, and remain unloaded for 30min to the minimum.
- 4.7.3 Cover the seating area in contact with HPM machine by a fine cotton with adequate dimension and proper material.
- 4.7.4 Put up seat pan and back pan assembly of HPM machine, such that the center planes could coincide for both seat and HPM machine.
- 4.7.5 Install foot and lower leg assemblies, and adjust the length of lower leg to the 50 percentile position, that of upper leg, to the 10 percentile position, and knee spacing, to 250mm.
- 4.7.6 Adjust the angle between foot and tibia to 90° ; place heel onto the floor, which shall extend to the forward direction as far as possible. Toe board shall be placed at a sufficiently far position, so as to avoid any potential interference of foot during the installation of HPM machine.
- 4.7.7 Install lower leg and upper leg weights, and level the HPM machine.
- 4.7.8 Cause the back pan incline forwards and leave the seat back; push the HPM machine backwards, until the seat pan comes into contact with the seat back. At the intersection between the hip angulo meter and T-bar, exert a 100N force horizontally backward; then restore the back pan onto the seat back.
- 4.7.9 Install hip weights. Then, alternatively install 6 torso weights to the left and right sides (including 2-big weights furnished by HRMD). The 2-big weights furnished by HRMD shall be installed at last, which shall be pushed to respective side and pressed down. In the entire course of weight installation, slightly press the T-bar to prevent the HPM from sliding forwards.
- 4.7.10 Incline the back pan up to the vertical position, and, within the range of 10° (5° from the plumb center plane to left and right side each), rock the HPM machine to left and right for three runs. Please note that, during rocking, the T-bar of HPM machine would deviate from the prescribed horizontal and vertical reference positions; therefore, during the rocking it is a must to exert a proper lateral force onto the T-bar. When swaying the HPM machine by holding the T-bar, attentions shall be paid to prevent any vertical or longitudinal force from being applied inadvertently. Upon above manipulations, both feet of the HPM machine shall be free of any restriction, so that the motion of the HPM machine would not be limited.
- 4.7.11 Hold the T-bar (to prevent the HPM machine from sliding forwards on the seat cushion) and restore the back pan onto the seat back. To assure the stable torso position, apply backwards a force not more than 10N at the CoG (center-of-gravity) position of the torso of the back pan module. Special attentions shall be drawn to that no downward or lateral force would be exerted onto the HPM machine.
- 4.7.12 Check whether the H-point machine is leveled, whether it is oriented due forwards, and whether the position falls on the seat centerline.
- 4.7.13 Alternatively lift left and right feet from the floor, until both feet cannot move forwards any more.
- 4.7.14 Move the toe board such that the toe could contact the 45° board plane within 230mm~270mm. Pedal front-and-back adjustment process should not affect the sitting posture above HPM knee hinge, that is, do not change the seat plate and backplane position.
- 4.7.15 If, after foot adjustment, the HPM machine cannot remain leveled, a proper force shall be exerted on the seat pan such that it could be horizontally anchored onto the seat.

- 4.7.16 Properly install the head restmeasuring device from up to down. During the installation, no external force shall be exerted which would otherwise impact the HPM machine position.
- 4.7.17 Adjust the head of HRMD to the leveled position.
- 4.7.18 Measure and record the torso angle of HPM machine.
- 4.7.19 Measure and record the H-point mark position on the HPM machine. For the H-point coordinates at both sides, the error of X_{HPM} value and Z_{HPM} value shall fall within $\pm 2.5\text{mm}$.
- 4.7.20 Move backwards the backset probe of HRMD, until it comes into contact with the head restraint. Such point is marked as the first contact point.
- 4.7.21 Measure and record the horizontal distance from the aforesaid first contact point to the rearmost point of head (bolt point of backset probe). Such distance is taken as the dummy reference backset ' B_{ref} '.
- 4.7.22 Repeat the above measurements twice, assuring that the error of measurement in the 3 runs (X_{HPM} , Z_{HPM} , and B_{ref}) falls within $\pm 5\text{mm}$. Failing that, additional measurement run shall be conducted, until the measurements (X_{HPM} , Z_{HPM} and B_{ref}) of 3 consecutive runs meet the error requirement (i.e., within $\pm 5\text{mm}$), and the average of the last 3 measurement runs shall be taken as the basis for the dummy positioning.

4.8 Head interference space of head restraint

- 4.8.1 If, during the adjustment process stated in Paragraph 4.7.17, the HRMD headform cannot be adjusted to horizontal due to the too forward position of head restraint, the following adjustments are necessary.
- 4.8.2 If the tilt of head rest is adjustable, then head rest shall be adjusted backwards, until the leveling of HRMD would not be interfered any longer; head rest shall be adjusted to the locking position.
- 4.8.3 If, after such adjustment of the tilt of head restraint, HRMD leveling is still impacted, or if the tilt of head rest is non-adjustable, seat back shall be adjusted backwards, until head rest would not interfere with the HRMD leveling any more.
- 4.8.4 Continue proceeding with the adjustments and measurements stated in Paragraphs 4.7.17~4.7.22.
- 4.8.5 The average torso angle of HPM machine in the three measurement plus 1.5° shall be taken as the pelvis target value for the positioning of BioRID dummy.

4.9 Dummy preparations and certification

4.9.1 Model of dummy

For the test, BioRID II dummy shall be employed.

4.9.2 Clothing of dummy

The dummy shall be dressed with two pairs of close-fitting, knee-length, spandex/lycra pants and two close-fitting, short-sleeved spandex shirts. The under layer of clothes shall be worn with the shiny/smooth side of the fabric facing out and the over-clothes with the shiny/smooth side against the underclothes (i.e. dull side facing out). The dummies feet shall be shod with size 45 Oxford-style, hard-soled shoes.

4.9.3 Test environment of dummy

- 4.9.3.1 Dummy shall be tested at the temperature of $22.5^\circ\text{C} \pm 3^\circ\text{C}$ and a relative humidity of 10%~70%.
- 4.9.3.2 Prior to test, dummy and seat shall be soaked in the standard test environment for 3h to the minimum.

4.9.4 Joint adjustments of dummy

- 4.9.4.1 Preferably joint adjustment of dummy shall be conducted in the very day of test. If prior adjustment is needed, it shall be conducted 24h prior to the start of test.
- 4.9.4.2 All dummy joints presenting stable friction shall be adjusted prior to the test. Dummy joints shall be adjusted in such a manner that dummy limbs may remain continual motion under the effect of 1g~2g.

4.9.5 Certification of dummy

4.9.5.1 Spine curvature check

- 4.9.5.1.1 With the pelvis adapter plate placed on a level surface, measure, under the static conditions, related distances and angles, and determine whether appropriate provisions are satisfied.
- 4.9.5.1.2 Curvature check shall be conducted once every 5 test runs.

4.9.5.2 Certification of impact

- 4.9.5.2.1 The dynamic response of BioRID II dummy is checked by attaching the spine, torso and head to a mini-sled that is impacted by a 33.4kg pendulum at a velocity of 4.76m/s±0.1m/s.
- 4.9.5.2.2 Dynamic impact certification of dummy shall be conducted once every 5 test runs.
- 4.9.5.3 Any part of dummy damaged during test shall be replaced.
- 4.9.5.4 All data for dummy certification shall be recorded and archived.

4.10 Test instrumentation and dummy transducers

- 4.10.1 Prior to the start of test, all instrumentations shall be already calibrated. Irrespective of the frequency of use, all instrumentations and transducers shall be calibrated once each year.
- 4.10.2 Test data gathering and measuring equipment shall have a minimum sampling frequency of 10kHz.
- 4.10.3 During test, test data gathering and measuring equipment shall record the data of -10ms~300ms to the minimum. '0ms' means the launching moment of the accelerating sled.
- 4.10.4 To ensure test accuracy, the channel amplitude class (CAC) of each transducer shall be set according to Table 31. If, during test, transducer measurement reaches the CAC, then the transducer concerned shall be re-calibrated.
- 4.10.5 For dummy head and head restraint, foil contact switch shall be used to measure the switch signals, and determine the contact and detachment states between head and head restraint.

Table 31 Channel test requirements for dummy transducers

Test location		CAC (channel amplitude class)	CFC (channel filtering class)
CoG acceleration of head (g)	Ax	100	60
	Ay	100	60
	Az	100	60
Upper neck load (N)	Fx+	1,400	1,000
	Fz+	4,500	1,000
Upper neck moment (Nm)	My	115	600
Lower neck load (N)	Fx+	5,000	1,000
	Fz+	5,000	1,000
Lower neck moment (Nm)	My	200	600
Thorax T1 acceleration (left/right) (g)	Ax	100	60
	Ax	100	60
Total number of measuring channels		11	

4.11 Installation of dummy

- 4.11.1 It shall ensure that, prior to the installation of BioRID II dummy, the seat shall remain unladen for 15min.
- 4.11.2 Place dummy on the seat.
- 4.11.3 Properly put up dummy safety belt, assuring that safety belt remains sufficiently slack to adjust dummy position where necessary.
- 4.11.4 Align dummy's midsagittal plane with the centerline of the seat.
- 4.11.5 Adjust dummy to be vertical, and the instrumentation platform in the head shall be laterally level.
- 4.11.6 Adjust the pelvis angle to 26.5° (±2.5°). If, since head rest interferes with the head space (Paragraph 4.8), backrest angle is adjusted backwards, then pelvis angle shall be adjusted to the actually measured torso angle plus 1.5° (Paragraph 4.8.5).
- 4.11.7 The dummy H-point shall be adjusted to a zone ±10mm (in vertical direction) and ±5mm (in longitudinal direction) from a target point. Such target point shall reside 20mm forward of the average value of the H-point as established in Paragraph 4.7.22.
- 4.11.8 Adjust the spacing of the lower legs so that the centerline of the knees and ankles is 200mm±10mm apart and ensures that the lateral planes of knees are vertical.
- 4.11.9 Cause the heel of dummy's shoe on the floor surface. The tip of the shoe shall rest on the 45° toe pan between 230mm and 270mm from the intersection.
- 4.11.10 Adjust dummy's arms as close to the torso sides as possible, in addition to contacting the seat back. The elbows shall be bent so that the palms face the dummy's thighs and the small fingers of both hands are in contact with the seat cushion.
- 4.11.11 Adjust the instrumentation plan of the head to the level ±0.5°, and adjust the dummy backset.
- 4.11.11.1 Mark the rearmost point of dummy's head, 95mm from the top of the skullcap backwards along the midsagittal plane.
- 4.11.11.2 Measure the horizontal distance between the rearmost point on the dummy's head and the first contact point marked on head rest(Paragraph 4.7.20), which is adjusted to the average B_{ref} (as determined in Paragraph 4.7.22) plus 15mm (±2mm).

Table 32 Requirements for dummy settings and tolerances

Position	Target	Tolerance
H-point (X-axis)	20mm forward X _{H_{PM}}	±5mm
H-point (Z-axis)	Z _{H_{PM}}	±10mm
Pelvis angle	26.5°	±2.5°
Head plane angle	0° (level)	±0.5°
Backset	B _{ref} +15mm	±2mm

4.12 Test photos

Table 33 lists some photographs necessarily to be taken prior to and after the test ("o" means mandatory).

Table 33 Test photographs

No.	Shooting angle of picture	View-finding scope	Pre-test	Post-test
1	Front view of dummy	Dummy and seat	o	o
2	Dummy at 45° to front	Dummy and seat	o	o
3	Side view of dummy	Dummy and seat	o	o
4	Dummy at 45° to rear	Dummy and seat	o	o
5	Front view of dummy	From dummy head to thorax	o	o
6	Dummy at 45° to front	From dummy head to thorax	o	o
7	Side view of dummy	From dummy head to thorax	o	o
8	Dummy at 45° to rear	From dummy head to thorax	o	o
9	Close view of head restposition		o	o
10	Particulars of damage, if any, to dummy, seat, etc.		x	o

4.13 High speed video

- 4.13.1 The test requires two cameras which record at 1000fps.
- 4.13.2 One high-speed camera shall record the overall test conditions of seat and dummy. Recording shall start at t=0 and end at t=300ms.
- 4.13.3 The other camera shall record the entire motion process of dummy head and seat head rest during the test. Recording shall start at t=0 and end at t=300ms.

4.14 Lighting system

Prior to the start of test, activate the no-flash lighting system intended for the high-speed cameras, and ensure that, upon test, the lighting system could remain normal functioning and the temperature of the environment surrounding the seat and dummy would not be too high.

4.15 Assessment criteria calculation

4.15.1 Calculation of dummy injury criteria

- 4.15.1.1 For each dummy transducer, the channel filtering class (CFC) shall be set as per Table 20.
- 4.15.1.2 By means of the switching signals as measured by the dummy-head rest/contact switch, determine the time of the first contact between head and head restraint, recorded as $T-HRC_{(Start)}$, and the time of detachment of the head from head restraint after the contact, recorded as $T-HRC_{(End)}$.

4.15.1.3 NIC

Neck injury criterion (NIC) is based on the relative horizontal acceleration and velocity of the occipital joint relative to T1.

$$NIC(t) = 0.2A_x^{rel}(t) + [V_x^{rel}(t)]^2$$

$$NIC_{max} = \underset{T-HRC_{(End)}}{Max} [NIC(t)]$$

Relative acceleration:

$$A_x^{T1}(t) = \frac{A_x^{T1Left}(t) + A_x^{T1Right}(t)}{2}, \quad A_x^{T1Left}, \quad A_x^{T1Right}, \quad A_x^{Head}$$

Where the unit is m/s^2

Relative speed:

$$V_x^{rel}(t) = \int_0^t A_x^{rel}(\tau) d\tau$$

4.15.1.4 Neck shearing force

For the neck shearing force, only the rearward motion portion of the head relative to torso shall be assessed, i.e., F_x is a positive value.

$$F_{x_{max}} = \underset{T-HRC_{(End)}}{Max} [F_x(t)]$$

4.15.1.5 Neck tension

For the neck tension, only the tensile portion shall be assessed, i.e., F_z is a positive force.

$$F_{z_{max}} = \underset{T-HRC_{(End)}}{Max} [F_z(t)]$$

4.15.1.6 Neck torque

Neck torque assesses two directions, namely, extension and flexion.

4.15.1.6.1 Upper neck torque

$$My_{\max}^{OC} = \underset{T-HRC_{(end)}}{Max} |My^{OC}(t)|$$
$$My^{OC}(t) = My^{upper}(t) - D \cdot Fx^{upper}(t)$$

Where: $D = 0.01778m$

4.15.1.6.2 Lower neck torque

$$My_{\max} = \underset{T-HRC_{(end)}}{Max} |My(t)|$$

4.15.2 Analysis of test film

4.15.2.1 Backrest flare angle

By taking the seat back angle at $T = 0$ as reference, track the variation curve of backrest angle (backrest flare angle is defined as the maximum rearward change of the backrest angle during the impact).

4.15.2.2 Track failure

Starting from $T=0$, follow up the displacement change curve of seat track motion portion in relation to fixed portion, and track failure is the maximum value in this relative displacement curve.

Chapter V Test Method of Pedestrian Protection

1 Vehicle preparation

1.1 Kerb mass

1.1.1 Refill the fuel tank with fuel (or an equivalent mass of water or other ballast) to the rated fuel tank capacity.

1.1.2 Inspect whether other liquids of vehicle (such as engine oil, brake fluid, detergent and anti-freeze fluid, etc) reach the highest liquid level and adjust.

1.1.3 Confirm that spare wheel and tools supplied with the vehicle are at relevant positions of vehicle, and eliminate articles that are not related to vehicle from the vehicle.

1.1.4 Check and adjust tyre pressure of all tyres to the tyre pressure value specified by vehicle manufacturer for half load of vehicle.

1.1.5 Remove the front vehicle license plate and its mounting brackets if these are removable.

1.1.6 Measure and record the total mass of the vehicle and load of the front and rear axles, and the measured total mass of vehicle is the kerb mass of the vehicle.

1.2 Additional weights

1.2.1 If the fore-aft position of front row seats is adjustable, it is necessary to adjust to mid-position of adjustable travel. If there is no locking position at the mid-position of seat, it is necessary to adjust to the first locking position rearward from the mid-position.

1.2.2 75kg additional weight should be respectively placed on the driver's seat and the front row occupant's seat.

1.2.3 It is necessary to ensure that the front wheels of vehicle are in the straight-ahead driving position.

1.2.4 If suspension is adjustable, the suspension should be adjusted in normal running attitude for 40km/h.

1.3 Suspension adjustment

Roll the vehicle forwards by a distance of at least 1m, then roll the vehicle rearwards by a distance of at least 1m, and repeat this for three times. Measure and record the height of intersection of transverse vertical planes of vehicle passing the four wheel centers and the upper edge of wheel arch. If vehicle suspension is adjustable, adjust as per the method of 1.2.4.

1.4 Normal ride attitude

1.4.1 After completion of vehicle preparation work specified in 1.1, 1.2 and 1.3, the vehicle is at normal ride attitude.

1.4.2 Vehicle manufacturer should specify the height of vehicle along the vertical direction (direction Z) at normal ride attitude with reference to marks, holes, or other signs on the vehicle. These marks should be capable of easily checking the vehicle height and vehicle attitude. If the deviation of vertical height of reference marks from the design height is within $\pm 25\text{mm}$ (including $\pm 25\text{mm}$), then the design height should be considered to be the normal ride height, and the vehicle can be adjusted to the design height for test. If the deviation of vertical height of reference marks from the design height is more than $\pm 25\text{mm}$, the normal ride height of vehicle actually measured at normal ride attitude of vehicle should be used.

2 Vehicle marking

2.1 General requirements

- 2.1.1 The vehicle should be marked as per requirement in this section, divide the front of vehicle into different areas, then assess by using appropriate impactor.
- 2.1.2 Before test, vehicle manufacturer should provide the predicted data of test zone of headform. Otherwise, evaluation should be performed as per equal width areas method.
- 2.1.3 All markings and measurements of vehicle should be made with the vehicle in its normal ride attitude.
- 2.1.4 The vehicle manufacturer should provide vehicle coordinates of all grid points of head or physically mark out on vehicle.
- 2.1.5 A comparison should be made between the actual test measurement results and the data provided by the vehicle manufacturer. The predicted results of headform test provided by manufacturer will be accepted only if the deviation from each other is within 10mm. When the deviation from each other is more than 10mm, vehicle manufacture should support to find out the root-cause of deviation. In accordance with the root-cause of deviation, C-NCAP Test Evaluation Department determines how to complete vehicle marking work.
- 2.1.6 The manufacturer should provide the predicted results for headform test zone. C-NCAP Test Evaluation Department should select partial predicted results for test, so as to verify the accuracy of the predicted results provided by the manufacturer.
- 2.1.7 For active deployable bonnet systems, the head impact point position marking should be made with the bonnet in the undeployed state, regardless of the working state of bonnet system.
- 2.1.8 In case of any gaps in markup areas of the vehicle front, apply tape along the outer contour of the vehicle and span these gaps, and the tape represents the contour of vehicle front. Arrange the tape as per the WAD marking procedure.

2.2 Bonnet leading edge reference line

The “bonnet leading edge” refers to the edge of front upper outer parts of vehicle, including the bonnet, wings, headlight and any other attachments. The bonnet leading edge reference line is defined as the geometric trace of the points of contact between a straight edge 1,000mm long and the front surface of the bonnet. The geometric trace consists of points of contact between straight edge and the bonnet leading edge, when the straight edge is held parallel to the vertical longitudinal plane of the vehicle and is inclined rearwards by 50° from vertical direction, and the lower end of straight edge is 600mm from the ground reference plane, see Figure 35. For vehicles having the bonnet top surface itself inclined at 50°, so that the straight edge makes continuous contact or multiple contacts rather than a point contact with bonnet, determine the reference line with the straight edge inclined rearwards at 40° from vertical direction. If the bottom end of the straight edge makes first contact with vehicle, then that contact point at the lateral position forms the bonnet leading edge reference line. If the top end of the straight edge makes first contact with vehicle, then the geometric trace of 1,000mm wrap around distance (WAD) defined in 2.5 of this Chapter forms the bonnet leading edge reference line at this position. The top edge of the bumper may also be regarded as the bonnet leading edge reference line if top edge of the bumper makes contact with the straight edge during this procedure.

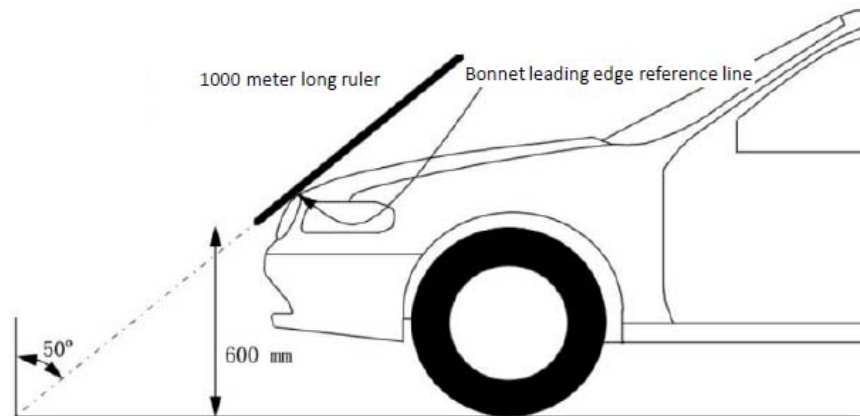

Figure 35 Marking diagram of the bonnet leading edge reference line

- 2.2.1 Fix a straight edge that is 1,000mm long inclined rearwards at 50° rearward from the vertical direction and with its lower end at a height of 600mm from ground surface. For vehicle of which the top surface of the bonnet is inclined at 50° so that the straight edge makes a continuous contact or multiple contacts rather than a point contact, determine the reference line with the straight edge inclined rearwards at an angle of 40° from the vertical direction at the moment. With straight edge in a longitudinal plane of vehicle, position the straight edge at one end of the bonnet and in contact with the bonnet.
- 2.2.2 Mark the point of contact of the straight edge and bonnet.
- 2.2.3 If the bottom end of the straight edge makes first contact with the vehicle, then mark this point of contact.
- 2.2.4 If the top end of the straight edge makes first contact behind the 1,000mm wrap around line, then use the geometric trace of the 1,000mm wrap around distance at the position as bonnet leading edge reference line.
- 2.2.5 Remove the straight edge away from the bonnet, move the straight edge towards the other end of bonnet by not more than 100mm and then back into contact with the bonnet.
- 2.2.6 Mark the point of contact of the straight edge and bonnet.
- 2.2.7 Repeat steps 2.2.3-2.2.6 across the whole width of the bonnet, join the marks on the bonnet to form a line and constitute bonnet leading edge reference line. The bonnet leading edge reference line may not be continuous and may be interrupted around areas such as vehicle badge and grill, etc.

2.3 Bonnet side reference line

The geometric trace formed by the uppermost points of contact between a straight edge 700mm long and the side of vehicle, when the straight edge is held parallel to the lateral vertical plane of vehicle and inclined inwards by 45°, while remaining in contact with the side of front structure of vehicle, the point of contact with rearview mirror is ignored. See Figure 36. Where there are multiple or continuous points of contact, the most outboard points of contact form the bonnet side reference line.

- 2.3.1 Position a straight edge that is 700mm long at 45° to the horizontal plane. With the straight edge held parallel to the lateral vertical plane of vehicle, position the straight edge at one end of side edge of vehicle and in contact with the bonnet or the front of wing of vehicle.
- 2.3.2 Mark the uppermost point of contact of the straight edge and bonnet or wing.
- 2.3.3 Remove the straight edge away from the bonnet or wing, move it towards the other end of the vehicle by not more than 100mm and then back into contact with the wing.
- 2.3.4 Mark the uppermost point of contact of the straight edge and bonnet or wing.

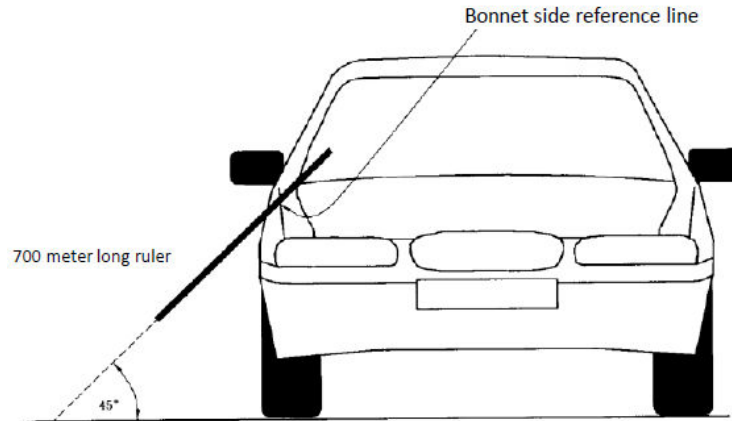

Figure 36 Marking diagram of bonnet side reference line

- 2.3.5 Repeat 2.3.3 and 2.3.4 in the scope of the length of the bonnet, wing and A-Pillar.
- 2.3.6 Join these marks to form a line. This line may not be continuous and may be interrupted around positions such as the wing and wheel rim, etc.
- 2.3.7 Repeat the above operation at the other side of the vehicle.
- 2.3.8 A partial modification of bonnet side reference line is allowed for the determination of the corner points.

2.4 Bonnet rear reference line

The geometric trace of the most rearward points of contact between sphere and front structure of vehicle when sphere of diameter 165mm rolls laterally across the frontal structure of vehicle while maintaining contact with the windscreen, see Figure 37.

- 2.4.1 Remove the wiper blades and arms.
- 2.4.2 A sphere of diameter 165mm at the vehicle center position on the frontal structure top surface of vehicle so that the sphere contacts the windshield.
- 2.4.3 Mark the most forward point of contact between the sphere and the vehicle's frontal structure top surface. Move towards one side of vehicle until the sphere contacts the bonnet side reference line, mark all points of contact during the motion process. Return to the initial position, and repeat the same operation at the other side of vehicle.

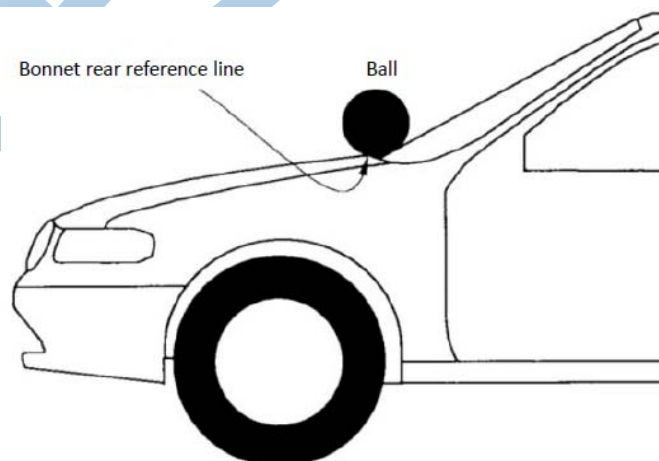

Figure 37 Marking diagram of the bonnet rear reference line

- 2.4.4 If the bonnet rear reference line is located at a wrap around distance of more than 2,100mm, then the 2,100mm wrap around line is used as the bonnet rear reference line.

- 2.4.5 Where the bonnet rear reference line and bonnet side reference line do not intersect, the bonnet rear reference line should be extended and/or determined by using a semi-circular template of radius 100mm. The template should be made of thin flexible material that easily bends to a single curvature in any direction. It is necessary to prevent template from formation of double or complex curvature which could result in wrinkling. The recommended template material is a foam backed thin plastic sheet to allow the template to fit closely to the surface of the vehicle.
- 2.4.6 Place the template on a horizontal surface, and mark the template with four points from "A" to "D", as shown in Figure 38. The template should be placed on the vehicle with "A" and "B" coincident with the side reference line. Ensuring that "A" and "B" remain coincident with the side reference line, the template should be moved progressively rearwards until the arc of the template makes contact with the bonnet rear reference line. Throughout the entire process, the template should be curved to follow, as closely as possible, the outer contour of the vehicle's bonnet top, without wrinkling or folding of the template. If the contact line between the template and bonnet rear reference line is tangential to template and the point of tangency lies on arc outside the arc scribed by points "C" and "D", then the bonnet rear reference line should be extended and/or determined along the circumferential arc of the template in contact with the bonnet side reference line, as shown in Figure 38.
- 2.4.7 If the template cannot make simultaneous contact with the bonnet side reference line at points "A" and "B" and tangentially with the bonnet rear reference line, or the point at which template contacts the bonnet rear reference line lies within the arc scribed by points "C" and "D", then additional templates should be used where the radius of the template may be increased progressively in increments of 20mm, until all the above criteria are met.
- 2.4.8 Install the blades and arms of wiper.

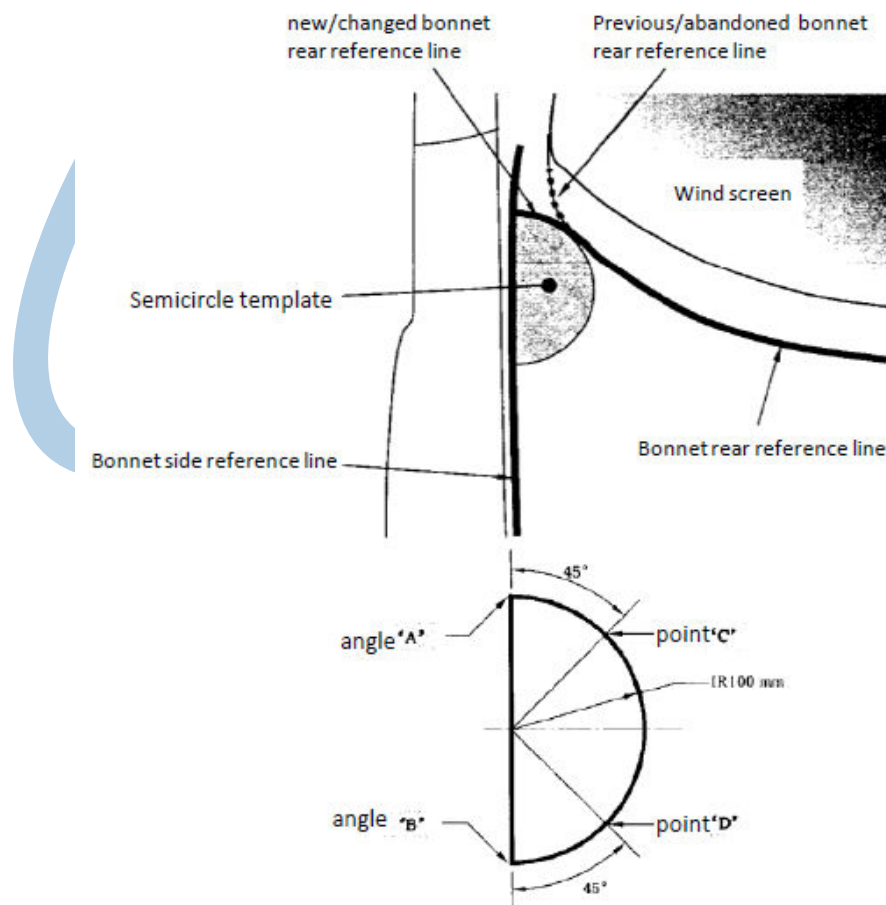

Figure 38 Bonnet rear and side reference lines intersection marking diagram and

template diagram

2.5 Wrap around line

Geometric trace formed on the outer surface of the vehicle front structure by one end of flexible wire when flexible tape or wire is in a vertical longitudinal plane of vehicle and is traversed across the front structure of vehicle, where vehicle is under normal ride attitude.

2.5.1 Begin at the vehicle center longitudinal vertical plane.

2.5.2 One end of a flexible wire is in contact with the ground reference plane and vertically falls below the front face of the bumper, and the other end is in contact with the front structure of vehicle.

2.5.3 Make marking at positions of 1,000mm, 1,500mm, 1,700mm and 2,100mm, during the entire operation process, the flexible wire should be held tight, meanwhile, ensure that the flexible wire is in the longitudinal vertical plane of vehicle. See Figure 39.

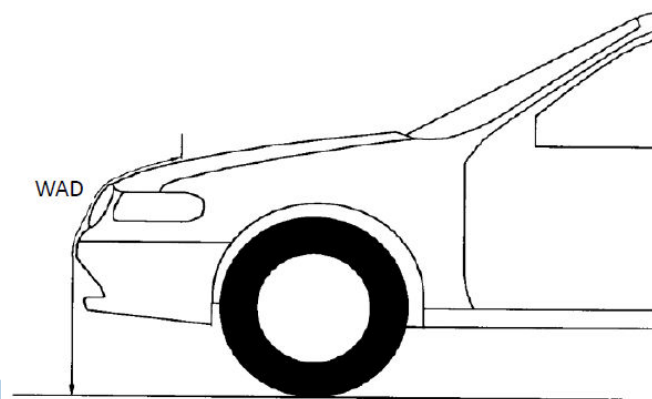

Figure 39 Marking diagram of wrap around line

2.5.4 Where there is depression on outer contour of vehicle, for example, wiper groove area behind bonnet, simulate outer contour of vehicle horizontally rearward along outer contour of vehicle by using tape. Mark wrap around distance on tape, and project vertically down onto vehicle structure.

2.5.5 Move flexible wire towards vehicle by not more than 100mm, then put one end of flexible wire to be in contact with ground reference plane, and the other end in contact with vehicle front, and make marking.

2.5.6 Repeat steps 2.5.1-2.5.4 until bonnet side reference line.

2.5.7 Respectively join the markings on bonnet to form wrap around lines at 1,000mm, 1,500mm, 1,700mm and 2,100mm.

2.6 Corner point

The corner point is defined as the intersection of the bonnet leading edge reference line and the bonnet side reference line. Where there are continuous or multiple intersections of the bonnet leading edge reference line and the bonnet side reference line, the most outboard intersection should be taken. In case of the corner point being located rearwards the WAD1000, mark the intersection of vehicle longitudinal vertical plane of corner point and WAD1000. Join the intersection and corner point along outer contour of bonnet to form the section of the bonnet side reference line, see Figure 40.

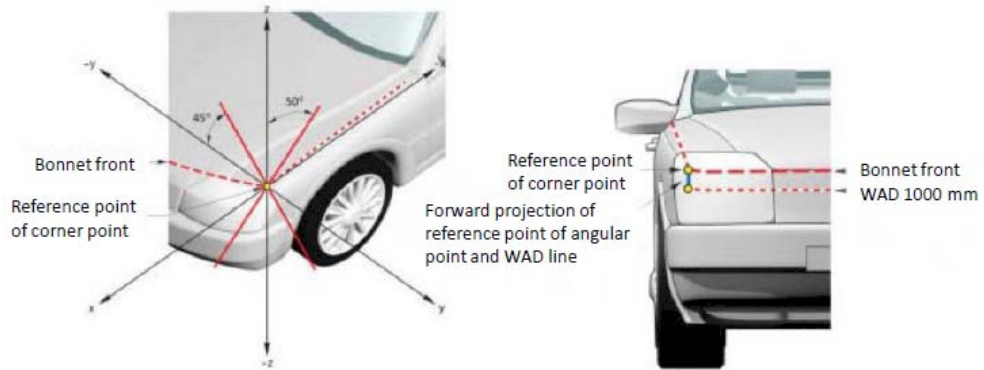

Figure 40 Corner point

2.7 Headform test zone

Headform test zone is defined as the area formed by WAD1000, WAD2100 and two bonnet side reference line. Child headform impact area is defined as the area between WAD1000 and WAD1500, including two wrap around lines; adult headform impact area is defined as the area between WAD1700 and WAD2100, including two wrap around lines.

If bonnet rear reference line is located between WAD1500 and WAD1700, then child headform test zone is defined as the area in front of bonnet rear reference line (including the reference line), and adult headform test zone is defined as the area between WAD1500 and WAD1700 behind bonnet rear reference line; if bonnet rear reference line is located behind WAD1700, then child headform test zone is defined as the area in front of WAD1700 (including WAD1700).

2.8 Bumper upper reference lines

For vehicles with an identifiable bumper structure, the geometric trace of the uppermost points of contact between a straight edge and the bumper, when the straight edge 700mm long, held parallel to the vertical longitudinal plane of vehicle and inclined rearwards by 20° from vertical direction, is traversed across the front of vehicle whilst maintaining contact with surface of the bumper. For a vehicle with no identifiable bumper structure, the geometric trace of the uppermost points of contact between a straight edge and the bumper, when the straight edge 700mm long, held parallel to the vertical longitudinal plane of vehicle and inclined rearwards by 20° from vertical direction, is traversed across the front of vehicle, whilst maintaining contact with the ground and the surface of the bumper. See Figure 41.

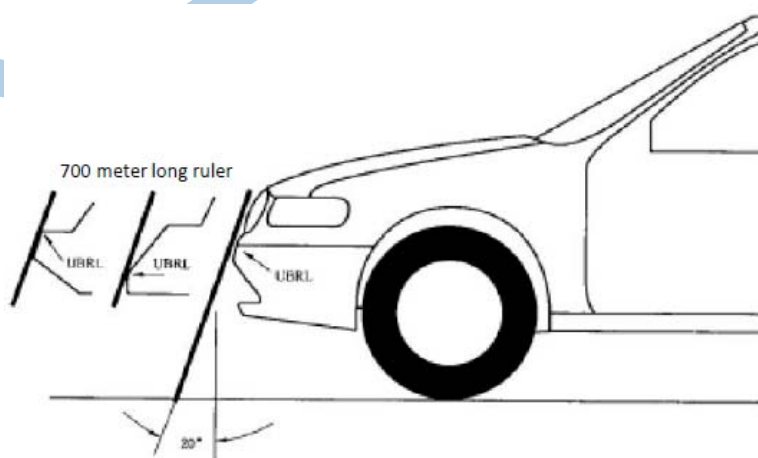

Figure 41 Marking diagram of upper bumper reference line

2.8.1 With a straight edge 700mm long inclined rearwards by 20° from vertical direction and in

a plane parallel to the vertical longitudinal plane of vehicle, position the straight edge at one end of bumper and maintain in contact with the bumper and the ground. The straight edge length may be shortened to avoid contact with structures above the bumper, the straight edge may also be lengthened to reach the bumper.

- 2.8.2 Mark the uppermost point of contact of the straight edge and bumper.
- 2.8.3 Remove the straight edge away from the bumper, move it towards the other end of the bumper by not more than 100mm and then into contact with the bumper again.
- 2.8.4 Mark the uppermost point of contact of the straight edge and bumper.
- 2.8.5 Repeat steps 2.8.3 and 2.8.4 along the whole length of the bumper.
- 2.8.6 Join the marking points to form upper bumper reference line. This line may not be continuous but may be interrupted around positions such as the license plate, etc.

2.9 The lower bumper reference line

The lower limit of valid points of contact between pedestrian and the bumper. The geometric trace of the lower most points of contact between a straight edge and the bumper, when the straight edge 700mm long, held parallel to the vertical longitudinal plane of vehicle and inclined forwards by 25° from vertical direction, is traversed across the front of vehicle, while maintaining contact with the ground and with the surface of the bumper, see Figure 42. The marking method is identical with the marking method for upper bumper reference line of 2.8.2~2.8.5.

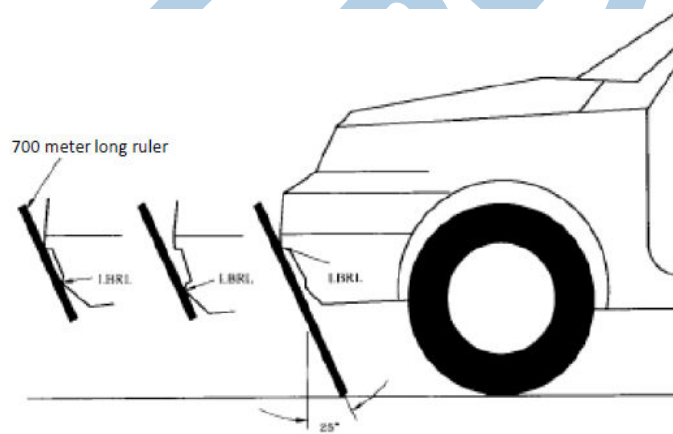

Figure 42 Marking diagram of the lower bumper reference line

2.10 Bumper corners

The corner of bumper is the point of contact of vertical centerline of front surface of a square board and the surface of the bumper, the square board of side length 236mm in a vertical plane makes an angle of 60° with the vertical longitudinal plane of vehicle and is tangential to the surface of the bumper. Where multiple contacts occur, the most outboard point of contact of Y-direction of vehicle is taken as the bumper corner. See Figure 43.

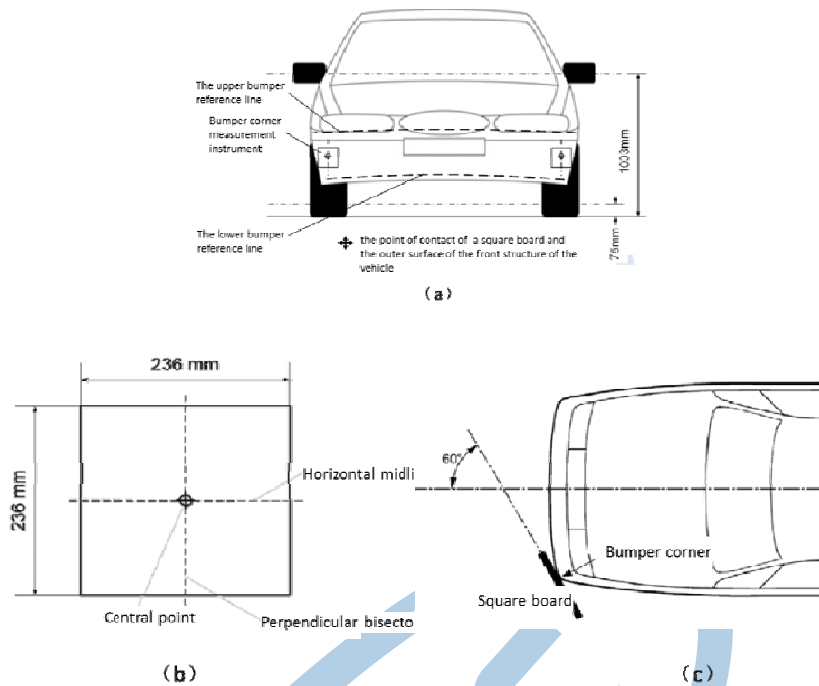

Figure 43 Marking diagram of bumper corner

- 2.10.1 The square board of side length 236mm makes an angle of 60° with the vertical longitudinal plane of vehicle, maintain the square board perpendicular to ground reference plane, and horizontal centerline of the square board parallel with ground reference plane.
- 2.10.2 Move the square board to get in contact with the front surface of vehicle bumper. During the motion process of the square board, it is necessary to ensure that the center point of the square board is no lower than the lower bumper reference line or 75mm above ground reference plane, whichever is higher; the center point of the square board is no higher than the upper bumper reference line or 1,003mm above ground reference plane, whichever is lower.
- 2.10.3 Mark the point of contact between vertical centerline of front surface of the square board and the front surface of the bumper.
- 2.10.4 The marked point of contact is the bumper corner, with the exception of point of contact between upper/lower boundary line of front surface of the square board and front surface of bumper and the point of contact between front surface of the square board and indirect visual device or tyre. Where there are multiple points of contact between vertical centerline of front surface of the square board and the surface of the bumper, the most outboard point of contact of Y-direction is taken as the bumper corner.
- 2.10.5 Mark bumper corner at the other side of vehicle as per the same method.
- 2.10.6 Remove plastic skin and auxiliary parts (energy absorption foam, etc) of bumper, mark the Y-direction outermost edge of cross beam of bumper inside skin or front longitudinal beam of vehicle. The cross beam of bumper refers to the structure behind bumper skin for protection of front end of vehicle, excluding energy absorption foam, bumper skin support device and any device used for protection in case of collision between vehicle and pedestrian.
- 2.10.7 Compare the area between bumper corners and the area between the Y-direction outmost edges of cross beam of bumper or front longitudinal beam of vehicle. Legform test zone takes whichever larger one of the two areas.
- 2.10.8 When the area between the Y-direction outmost edges of cross beam of bumper or front longitudinal beam of vehicle is larger, record the distance from vehicle centerline and area edge, reinstall bumper skin, and mark out the boundary of legform test zone on

bumper skin.

2.11 Marking headform impact area grid points

2.11.1 Mark the longitudinal centerline of the vehicle on the bumper, bonnet top, windscreen and roof.

2.11.2 Mark wrap around distances on the vehicle longitudinal centerline at 100mm intervals along vehicle front outer contour, start from WAD1000 and end at WAD2100. For vehicles with a V-shaped front end, it may also be necessary to mark WAD2200 and 2300, etc. See Figure 44.

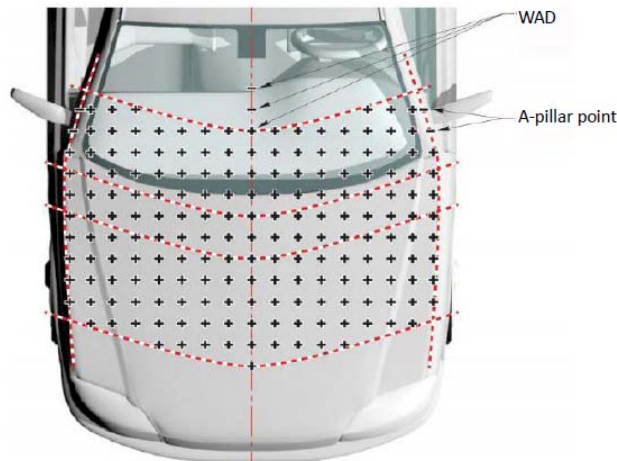

Figure 44 Marking diagram of headform test grid points

2.11.3 Starting at marking points at the longitudinal centerline, make marks every 100mm respectively in both lateral directions of vehicle up to the bonnet side reference lines. The 100mm should be measured horizontally in a lateral vertical plane of vehicle.

2.11.4 Repeat step 2.11.3 for every marking point on the longitudinal centerline until the entire headform impact test zone is covered with grid points. For special shape of the vehicle (vehicle of V-shaped vehicle front end), it may be necessary to also mark points at the wrap around distance such as 2,200mm and 2,300mm, etc.

2.11.5 On A-pillars, it is necessary to mark the intersection of the lateral vertical plane and the side reference line.

2.11.6 When there are grid points below outer contour of vehicle, rearwards from adjacent grid points close to vehicle head direction, simulate the outer contour of vehicle by adhesive tape along horizontal direction, and mark grid point on adhesive tape to replace the underlying grid point. See Figure 45.

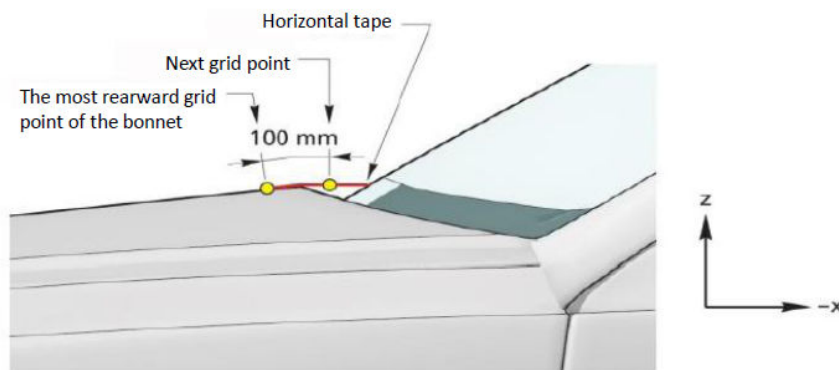

Figure 45 Marking of grid points beneath outer contour of vehicle

2.11.7 If grid point does not fall on wiper structure, simulate the outer contour of the vehicle top

by using an adhesive tape without consideration of wiper structure.

- 2.11.8 Remove points that have a distance less than 50mm to the side reference lines, the distance is measured in the lateral direction of vehicle (Y direction), but excluding those points which are on A-pillar side reference line. See Figure 46.

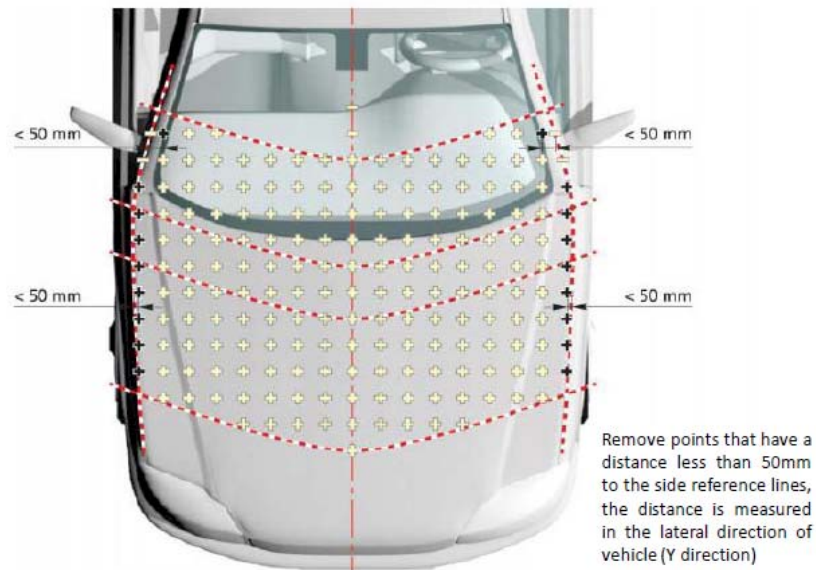

Figure 46 Removal of grid points that are less than 50mm from side reference line

- 2.11.9 The remaining grid points are used for the assessment of vehicle's protection for pedestrian head from impact. In the test, these grid points are tested as the aiming points.
- 2.11.10 Where the vehicle is equipped with an active deployable bonnet system, it is necessary to take the aiming points in the undeployed state of bonnet.
- 2.12 Numbering of the headform test zone grid points**
- 2.12.1 Child headform test grid points will contain the prefix "C", and adult headform test grid points will contain the prefix "A".
- 2.12.2 The grid point at the intersection between the vehicle longitudinal centerline and the WAD1000 wrap around line should be marked as C0,0.
- 2.12.3 The 1st numeral after the prefix represents row and is increased by increment rearwards, the 2nd numeral after the prefix represents column and is increased by increment towards the right of vehicle, and is decreased by increment towards the left of vehicle. See Figure 47.

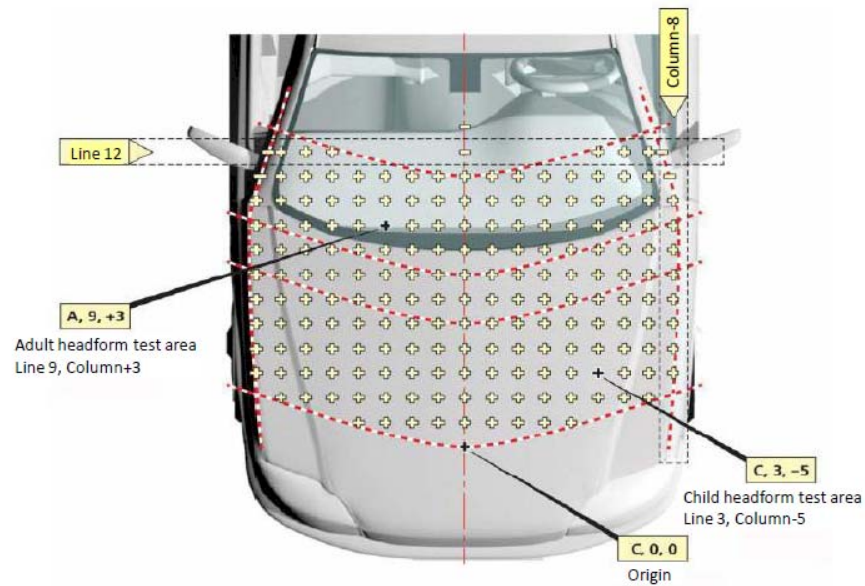

Figure 47 Numbering of the headform impact area grid points

2.13 Marking of equal width areas of headform test zone

When the predicated result of grid point is not provided by vehicle manufacturer, mark WAD1000, WAD1250, WAD1500, WAD1800 and WAD2100 as per the wrap around line marking method defined in 2.5 of this section, then make marking of headform test zone as per the equal width areas method as per this section.

- 2.13.1 Starting from WAD1000, use flexible tape or flexible wire, measure the distance between the intersections of WAD1000 and bonnet side reference line (measure between the two points along outer contour of bonnet rather than along WAD1000). Record the distance.
- 2.13.2 Divide the distance into 12 equal parts, and mark the equal division point between two side reference lines.
- 2.13.3 Flexible wire contacts the foremost point of WAD1000, and intersects with two side reference lines in lateral vertical plane of vehicle, measure the distance between two intersections (directly measure between the two side reference lines rather than along WAD1000). Record the distance.
- 2.13.4 Divide the distance into 12 equal parts, and mark the equal division points between two side reference lines.
- 2.13.5 Join the points of 12 equal divisions corresponding to two measurements, these connection lines respectively intersect with WAD1000, and mark the intersection, see Figure 48.

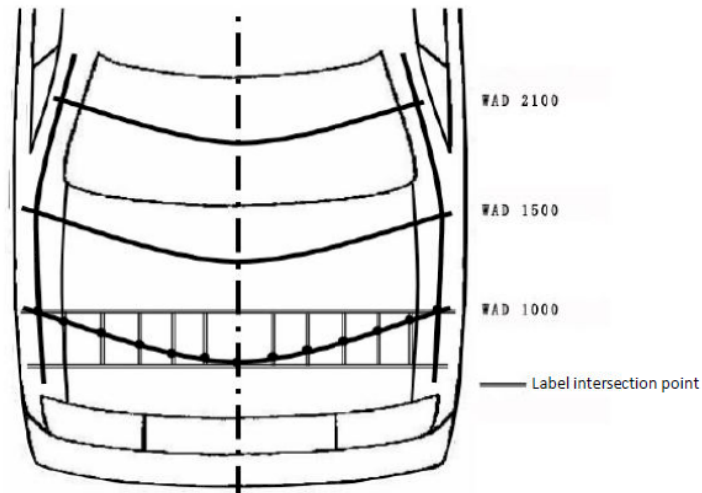

Figure 48 Diagram of division of WAD1000 into 12 equivalent parts

- 2.13.6 Respectively divide WAD1500 and WAD2100 into 12 equal parts as per the method of steps 2.13.1-2.13.5.
- 2.13.7 Join relevant intersections of WAD1000 and WAD1500.
- 2.13.8 Join relevant intersections of WAD1500 and WAD2100. See Figure 49.

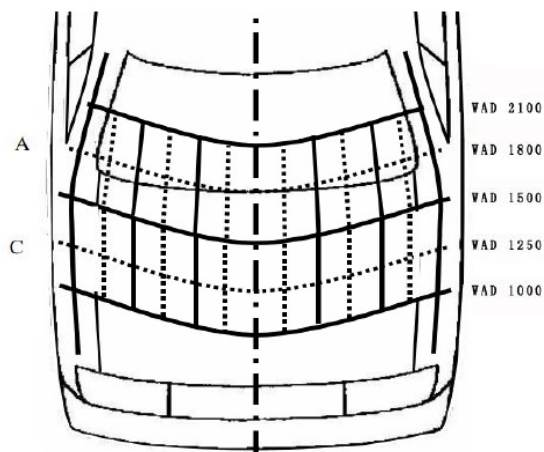

Figure 49 Diagram of division of headform test zone into 12 equivalent parts

- 2.13.9 The headform test zone is divided into 12 equal width areas. The 6 equal width areas close to vehicle head are marked in turn as C1, C2, C3, C4, C5 and C6 from the right side of vehicle to the left side of vehicle, and the 6 equal width areas close to windshield are marked in turn as A1, A2, A3, A4, A5 and A6 from the right side of vehicle to the left side of vehicle.
- 2.13.10 Each equal width area is divided into 4 quarters, headform test zone contains 12 equal width areas and 48 quarters. In each equal width area, the upper row is marked in turn as A and B from the right side of vehicle to the left side of vehicle, and the lower row is marked in turn as C and D. See marking method of each quarter as per Figure 50. The marked quarter in equal width area A3 is A3C and the marked quarter in equal width area C4 is C4B.
- 2.13.11 Number the test point by using the mark of the quarter which test point locates in. For quarter(s) of test evaluation added by vehicle manufacturer, the number of the test point should embody the specified quarters. For example, vehicle manufacturer specifies C2B, C2C and C2D in equal width area C2 as quarters which are evaluated by the additional test point, the test point selected upon test evaluation is in quarter C2C, the test point is

numbered as C2C (bcd). See Figure 50.

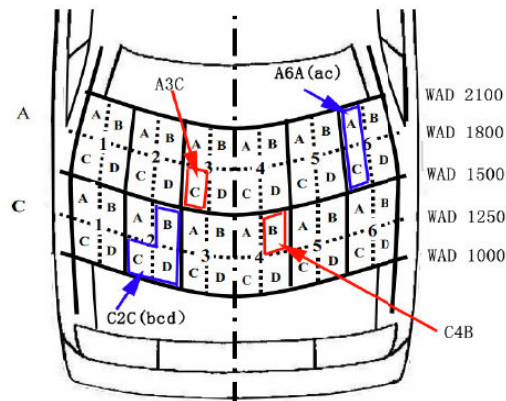

Figure 50 Marking of equivalent divisions of headform test zone

2.14 Marking legform test zone grid points

- 2.14.1 Starting at the intersection of the vehicle longitudinal center plane and upper bumper reference line, make marking every 100mm in both sides of vehicle on the upper bumper reference line. The 100mm distance is measured horizontally in lateral vertical plane of vehicle until the edge of legform test zone. See Figure 51.

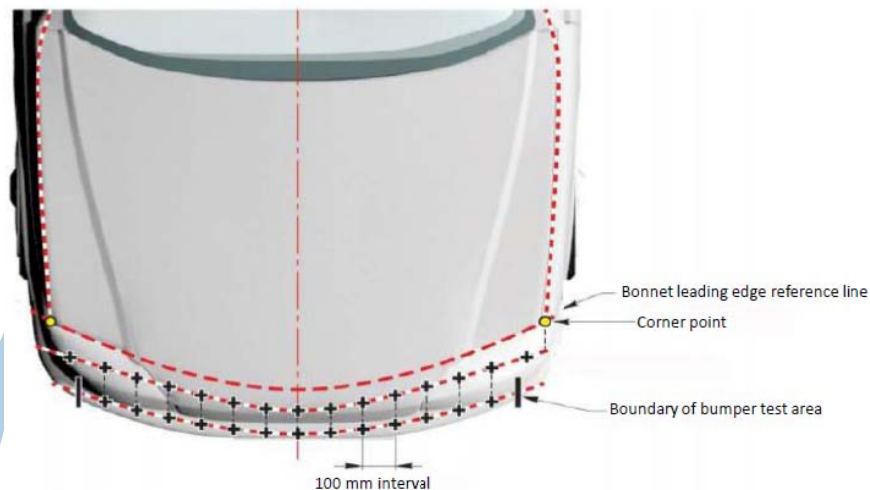

Figure 51 Marking diagram of legform test zone grid points

- 2.14.2 Where the distance between the outermost grid point marked in 2.14.1 and the edge of the legform test zone is more than 50mm, a grid point will be added 50mm outboard of the outermost grid point. The 50mm distance is measured horizontally in a lateral vertical plane of vehicle.

2.15 Numbering of legform test zone grid points

- 2.15.1 Legform test zone grid points will contain the prefix “L” or “U”, “L” is used for lower legform (FLEX-PLI) and “U” for upper legform.
- 2.15.2 The grid points at intersection of longitudinal median plane and upper bumper reference will be numbered as L0 or U0.
- 2.15.3 The points on the right side of the vehicle longitudinal median plane from the vehicle direction will be numbered in turn as L+1 (U+1), L+2 (U+2) and L+3 (U+3), etc. The points on the left side of the vehicle longitudinal median plane will be numbered in turn as L-1 (U-1), L-2 (U-2) and L-3 (U-3), etc. See Figure 52.

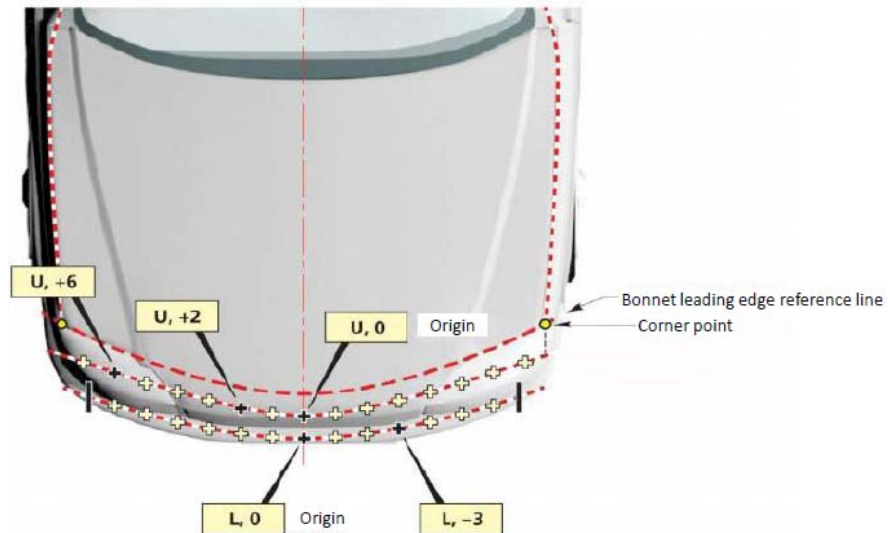

Figure 52 Numbering diagram of legform test zone grid points

3 Headform test

3.1 Predicated results of headform test zone

3.1.1 Before test, the vehicle manufacturer should provide the predicated value of all grid points in headform test zone or color distribution diagram of the predicated results to C-NCAP Administration Center.

3.1.2 As per Table 34, HIC_{15} value of each grid point corresponds to relevant color, color distribution diagram of the predicated results can be plotted as per the predicated value in headform test zone.

Table 34 Colors comparison Table of the predicated values of headform test

HIC_{15} interval	Color
$HIC_{15} < 650$	Green ■
$650 \leq HIC_{15} < 1,000$	Yellow ■
$1,000 \leq HIC_{15} < 1,350$	Orange ■
$1,350 \leq HIC_{15} < 1,700$	Grey ■
$1,700 \leq HIC_{15}$	Red ■

3.1.3 Specific grid points of headform test zone should be defined as default red or default green in the predicated results. The default color grid points should not include those randomly selected grid points and should not be tested, and should not participate calculation of correction factor of the predicated results.

3.1.3.1 Grid points on A-pillar should be defined as default red, unless vehicle manufacturer provides data that can prove that the headform test results HIC_{15} for grid points in the area is less than 1,700. Grid points on the A-pillars refer to grid points on the side reference line that are rearward of the bonnet rear reference line.

3.1.3.2 Grid points of windshield area other than those areas below should be defined as default green.

(1) Area of windshield that is within 165mm (including 165mm) of the windscreen mounting frame. The 165mm should be measured along inner side of ceramic strip of windshield or the edge of bottom of the windscreen (other structures such as interior trim), whichever is closer to center of windshield. See Figure 53.

(2) Area where there are other structures on bottom of the windscreen, or there are other structures within 100mm of bottom of the windscreen measured along the

direction of velocity vector of headform test.

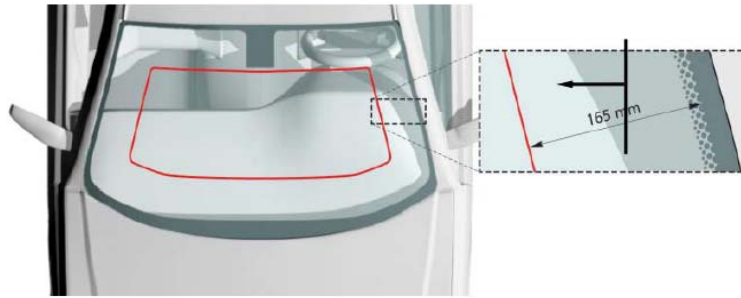

Figure 53 Windscreen periphery measurement

- 3.1.4 Before test, verify the position of default color grid points.
 - 3.1.5 Specific grid points in headform test zone that are unpredictable should be marked with blue color in the predicted results color distribution diagram.
 - 3.1.5.1 Vehicle manufacturer should provide test results of blue grid points and/or CAE results to prove that the grid point test results are unpredictable.
 - 3.1.5.2 Blue grid points can be either single or multiple, and adjacent grid points will form a blue zone.
 - 3.1.5.3 Number of blue zones in the entire headform test zone should be not more than 8. C-NCAP laboratory may select any grid point that causes large injury of pedestrian in a certain blue zone for test, all grid points in the blue zone should be assessed as per test results of the grid point, and color of grid points in blue zone is acquired as per Table 34.
 - 3.1.5.4 Blue zone should not incorporate those randomly selected grid points, and should not participate calculation of correction factor of predicated results.
 - 3.1.6 Where predicted data of headform test zone is not provided by the manufacturer, segmentation and marking should be in compliance with 2.13, and C-NCAP Test Evaluation Department should select position that may cause large injury upon pedestrian for test and evaluation.
- 3.2 Headform test program**
- 3.2.1 When vehicle manufacturer provides the predicated results of headform test zone, perform headform test as per the following program.
 - 3.2.1.1 Randomly select 8 grid points from headform test zone and perform verification test.
 - 3.2.1.2 When vehicle manufacturer deems that it is necessary to add number of test points, so as to acquire more accurate assessment results, manufacturer may propose to add test points, the additional test points should not exceed 8, and number of additional test points should be proposed upon submitting of predicated results.
 - 3.2.1.3 C-NCAP Test Evaluation Department should randomly select all verification test points at the same time.
 - 3.2.1.4 C-NCAP Test Evaluation Department should randomly select all verification test points in headform test zone other than blue grid points and default color grid points, and position of test point should be random.
 - 3.2.1.5 Test results of all verification test points should be used for calculation of correction factor.
 - 3.2.2 When vehicle manufacturer does not provide the predicated results of headform test zone, perform headform test as per the following program.
 - 3.2.2.1 Before test, C-NCAP Test Evaluation Department should select 1 test point in each equal width area, and the maximum number of test points selected should not exceed

12.

- 3.2.2.2 Headform impactor should be selected as per position of test point and as per the requirements of 2.7 in this section.
- 3.2.2.3 Distance from headform test point to bonnet side reference line should be not less than 82.5mm and the distance between any two test points should be not less than 165mm. When a certain area is located on A-pillar and the distance from side reference line does not meet the above requirements, don't perform test.
- 3.2.2.4 Where it is impossible to perform test at position where windshield base position may cause large injury upon pedestrian due to the distance requirement in 3.2.2.3, then score point is awarded to the quarter as per adjacent or symmetrical quarter. The windshield base position refers to plastic ventilation cover plate, wiper and parts that will not move with opening of bonnet.
- 3.2.2.5 For selection of test point, it is necessary to select the position that may easily cause the largest injury in each equal width area as per the head injury degree. In the entire headform test zone, it is necessary to consider spacing between test points when selecting test points.
- 3.2.2.6 Before start of test, when vehicle manufacturer deems that test points selected in a certain equal width area cannot sufficiently reflect the performance of the equal width area, vehicle manufacturer may specify to perform one additional test in the equal width area. Vehicle manufacturer should specify the equal width area where additional test points are located, and should specify quarter with additional test point evaluation at the same time. Quarter with additional test evaluation may be a certain quarter or two quarters or three quarters in the additional equal width area. For the equal width area for which additional test is specified, C-NCAP Test Evaluation Department should select 1 test point respectively in the quarter(s) with additional test evaluation and quarter(st) without additional test evaluation, and select the position that may cause large injury upon pedestrian, and test points should meet the requirements of 3.2.2.3. Number of tests added by manufacturer should be not more than 8.
- 3.2.2.7 When test point is located on windshield, and meets default green requirement, full points are awarded; when test point is located on A-pillar and default color is red, no point is awarded. It is not required to perform test for the default test point, unless vehicle manufacturer can provide evidence to prove that test point will get different test results.
- 3.2.2.8 Two symmetric points featuring identical structure can be selected as test point at the same time. It is not required to perform test for the 2nd test point, and it is allowed to evaluate the test results as per the 1st test point, unless vehicle manufacturer can provide evidence to indicate that the test results of the two test points are different, or C-NCAP Test Evaluation Department deems that different test results will be acquired in the quarter with additional test specified by vehicle manufacturer. It is necessary to reach agreement regarding whether test should be performed at symmetric points before start of test. In case of dispute, C-NCAP Test Evaluation Department will determine whether to perform test as per the actual situations.
- 3.2.2.9 Select 1 test point at most in each equal width area, and evaluate the test results of test point both in quarter of test point and quarters where no test point is selected, with the exception of the quarter(s) with additional test evaluation specified by vehicle manufacturer.

3.3 Requirements on headform test

- 3.3.1 The selected grid test point should be tested as the aiming point. For active deployable bonnet system, select the aiming point in the non-working condition of system, and perform test as per the actual working condition.
- 3.3.2 The centerline of the headform impactor should pass through the aiming point. See Figure 54.

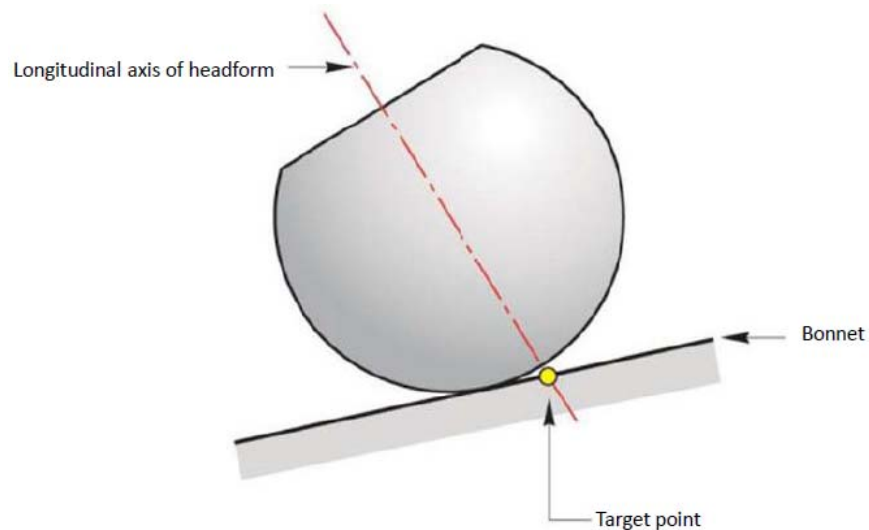

Figure 54 Schematic diagram of test point acting as the aiming point

3.3.3 The influence of gravity should be considered in the test. Under the influence of gravity, the flight trajectory of headform impactor may deviate.

3.3.4 Positioning of test system may be subject to influence of the following parameters, it is necessary to determine the accurate position of test system as per the following parameters:

- Headform diameter;
- Distance of free flight of headform;
- Impact angle of headform;
- Angle of bonnet at test point;
- Test speed.

3.3.5 When headform impactor impacts front structure of vehicle, it is necessary to ensure the impact speed and impact angle of headform impactor.

3.4 Headform impactor and sensor

3.4.1 In headform test, use child headform impactor of 3.5kg and adult headform impactor of 4.5kg.

3.4.2 Child headform impactor (see Figure 55).

The child headform impactor should be made of aluminum, be of homogenous construction and be of spherical shape. The diameter should be 165 ± 1 mm. The mass should be 3.5 ± 0.07 kg. The moment of inertia about an axis through the center of gravity and perpendicular to the direction of impact should be within the range of 0.008 to 0.012 kgm^2 . The center of gravity of the headform impactor including instrumentation should be located in the geometric center of the sphere with a deviation of ± 2 mm. The sphere should be covered with a 14 ± 0.5 mm thick synthetic skin, which should cover at least half of the sphere.

3.4.2.1 Child headform instrumentation

A recess in the sphere may allow for mounting one triaxial or three uniaxial acceleration sensors, the deviation between sensor mounting block along measurement axis direction and the center of the sphere is within ± 10 mm, and the deviation between sensor mounting block for the perpendicular direction to the measurement axis and the center of the sphere is within ± 1 mm. If three uniaxial acceleration sensors are used, one of the acceleration sensors should have its measurement axis perpendicular to the

mounting face A (see Figure 55) and its impactor block should be mounted at a position within a cylindrical deviation field of 1mm radius and 20mm length. The center line of the deviation field should be perpendicular to the mounting face and its mid-point should coincide with the center of the sphere of the headform impactor.

The remaining acceleration sensors should have their measurement axes perpendicular to each other and parallel to the mounting face A and the mounting block should be positioned within a spherical deviation field of 10mm radius. The center of the deviation field should coincide with the center of the sphere of the headform impactor.

See definition of the instrumentation response value CFC as per ISO 6487:2002, and CFC should be 1,000. See definition of the CAC response value as per ISO 6487:2002, and CAC of acceleration sensor should be 500g.

3.4.2.2 The first natural frequency

The first natural frequency of the headform impactor should be over 5,000Hz.

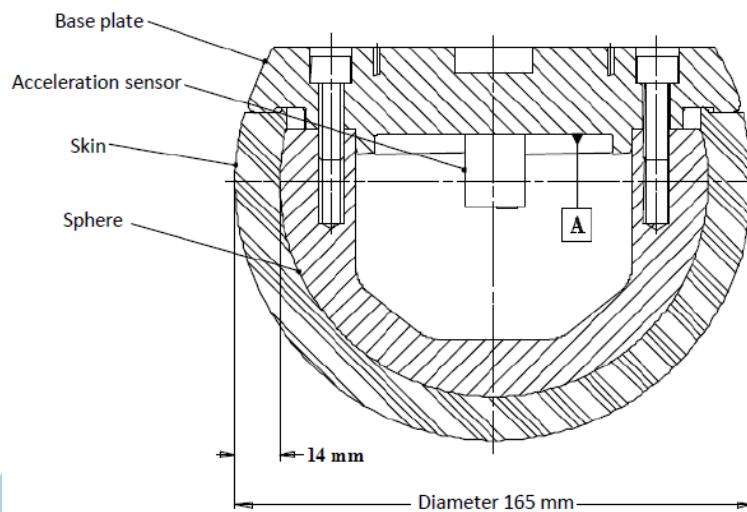

Figure 55 Diagram of child headform impactor

3.4.3 Adult headform impactor (see Figure 56)

Adult headform impactor should be made of aluminum, should be of homogeneous structure and spherical. The diameter is 165 ± 1 mm. The mass should be 4.5 ± 0.1 kg. The moment of inertia of axis passing through center of gravity and perpendicular to impact direction should be within 0.010 - 0.013 kgm². Center of gravity of headform impactor including instrument should be located in the geometric center of the sphere with a deviation of ± 5 mm.

The sphere should be covered with a 14 ± 0.5 mm thick synthetic skin, which should cover at least half of the sphere.

3.4.3.1 Adult headform instrumentation

A recess in the sphere should allow for mounting one triaxial or three uniaxial acceleration sensors, the deviation between sensor impact block along measurement axis direction and the center of the sphere is within ± 10 mm, and the deviation between sensor impact block for the perpendicular direction to the measurement axis and the center of the sphere is within ± 1 mm.

If three uniaxial acceleration sensors are used, one of the acceleration sensors should have its measurement axis perpendicular to the mounting face A (see Figure 56) and its impact block should be positioned within a cylindrical deviation field of 1mm radius and 20mm length. The center line of the deviation field should be perpendicular to the mounting face and its mid-point should coincide with the center of the sphere of the headform impactor.

The remaining acceleration sensors should have their measurement axes perpendicular to each other and parallel to the mounting face A and impact block should be positioned within a spherical deviation field of 10mm radius. The center of the deviation field should coincide with the center of the sphere of the headform impactor.

See definition of the instrumentation response value CFC as per ISO 6487:2002, and CFC should be 1,000. See definition of the CAC response value as per ISO 6487:2002, and CAC of acceleration sensor should be 500g.

3.4.3.2 The first natural frequency

The first natural frequency of the headform impactor should be over 5,000Hz.

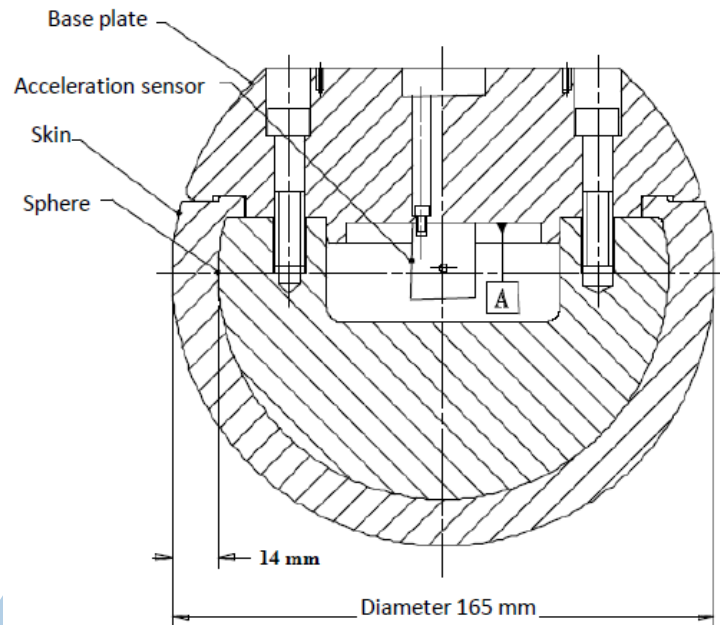

Figure 56 Diagram of headform impactor

3.4.4 Rear face of headform impactor

A rear flat face should be provided on the outer surface of the headform impactor which is perpendicular to the direction of travel and perpendicular to the measurement axis of one of the acceleration sensors as well as being a flat plate capable of providing for convenience to installation of the acceleration sensor and an attachment point for the propulsion system.

3.4.5 Calibration of headform impactor

Headform impactor should meet the performance requirements specified in section 3.5. The calibrated impactor may be used for a maximum of 20 impact tests before re-calibration. The impactor should also be re-calibrated if more than one year has elapsed since the previous calibration or if any impactor sensor output, in any impact, has exceeded the specified CAC.

3.4.6 Calibration of headform

3.4.6.1 Calibration of headform uses drop test calibration method, and should meet the requirement of 3.4.6.2 When calibration is performed as per 3.4.6.3.

3.4.6.2 When the headform impactors are dropped from a height of $376\text{mm} \pm 1\text{mm}$ in accordance with 3.4.6.3, the peak resultant acceleration measured by acceleration sensor installed in the headform impactor should meet the following requirements:

- a) For the child headform impactor, should be not less than 245g and not more than 300g;

b) For the adult headform impactor, should be not less than 225g and not more than 275g.

3.4.6.3 Headform calibration procedure

3.4.6.3.1 During calibration, ambient temperature should be $20^{\circ}\text{C}\pm 2^{\circ}\text{C}$, and environmental relative humidity should be $40\%\pm 30\%$, and test impactor should be stored in the environment for at least 4h prior to calibration test.

3.4.6.3.2 The headform impactor should be suspended from a drop rig, as shown in Figure 57.

3.4.6.3.3 The headform impactor should be dropped from the specified height. The dropping method should ensure instant release of headform impactor onto a rigidly supported flat horizontal steel plate. The steel plate should be a square of thickness over 50mm and area over $300\text{mm}\times 300\text{mm}$, the surface should be clean and dry, and the roughness should be between $0.2\mu\text{m}$ - $2.0\mu\text{m}$.

3.4.6.3.4 When headform impactor is dropped, the rear face of impactor should be at the test impactor angle with respect to the vertical direction. The suspension mode of the headform impactor should ensure that headform impactor does not rotate during the fall process.

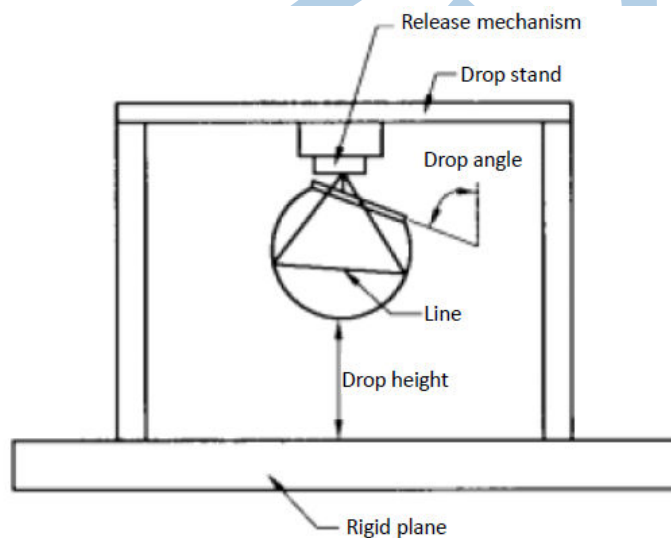

Figure 57 Schematic diagram of headform dropping test

3.4.6.3.5 The drop test should be performed for three times, and the headform impactor should be rotated 120° around its symmetrical axis for each test.

3.5 Headform test procedure

3.5.1 Ensure that vehicle test preparation has been performed as per the requirements in section 1.

3.5.2 Ensure that vehicle is in normal ride attitude during the marking process.

3.5.3 Ensure that headform, vehicle, launch system and data acquisition system have been kept under temperature environment of 16°C - 24°C for at least 2h before test.

3.5.4 Install the required headform onto launch system, and select headform impact as per the requirements of section 2.7.

3.5.5 Headform test zone describes the position of test point, and position of test point determines which type of headform impactor is used, when test point is not consistent with the 1st contact point, selection of headform impactor is determined by the position of test point. For example, there is a test point on the windshield base between 1,500mm wrap around line and 1,700mm, even though the first contact point is located on the rear edge of bonnet, it is necessary to perform test by using adult headform impactor.

- 3.5.6 Adjust the fore-aft position of vehicle, so as to ensure the free flight distance of headform.
- 3.5.7 Adjust the launch system so that the headform is launched to the test point as per correct angle.
- 3.5.8 The direction of impact should be in the longitudinal vertical plane of the vehicle, in the scope of accuracy of $\pm 2^\circ$. When vehicle is located on ground surface, the direction of impact of headform should be downward and rearward of vehicle. When child headform is used for test, the impact angle in relation to ground reference plane is $50^\circ \pm 2^\circ$, when child headform test point is located on or before bonnet front edge reference line, the impact angle in relation to ground reference plane is $20^\circ \pm 2^\circ$. When adult headform is used for test, the impact angle in relation to ground reference plane is $65^\circ \pm 2^\circ$. For impact angle prior to the moment of the first contact, the influence of gravity should be considered.
- 3.5.9 The allowable deviation of headform centerline from the selected grid point is $\pm 10\text{mm}$.
- 3.5.10 Set up launch system so that the speed of the 1st contact moment is 40km/h. The accuracy of speed measurement device reaches $\pm 0.072\text{km/h}$ at least. The speed measured at the 1st contact moment should consider the influence of gravity acceleration.
- 3.5.11 Launch headform impactor and start test.

4 Legform test

4.1 Legform test program

- 4.1.1 Where lower bumper reference line height at grid point position in legform test zone is less than 425mm, use lower legform for test; where lower bumper reference line height at grid point position in legform test zone is higher than 500mm, use upper legform for test; where lower bumper reference line height at grid point position in legform test zone is between 425mm and 500mm, the manufacturer may select to use lower legform or upper legform for test. If upper legform is used for test, vehicle manufacturer should submit description to C-NCAP before start of test.
- 4.1.2 If the structure at positions of symmetrical grid points at two sides of vehicle is different, manufacturer should provide data evidence before starting test.
- 4.1.3 The selection principle of legform test point is to select one grid point as test point from every other grid point starting L0 point or L1.
- 4.1.4 Where structure along the two sides of vehicle is symmetrical by default, C-NCAP Test Evaluation Department selects any one of two symmetrical grid points for test.
- 4.1.5 For grid points that have not been tested, take the worse test results of two grid points adjacent to it.
- 4.1.6 Where vehicle manufacturer deems that it is necessary to add number of test points so as to acquire more accurate evaluation results, or deems that symmetry does not apply to certain grid points, manufacturer may specify additional test point before start of test respectively for two potential initial test points of L0 and L1.

4.2 Legform impactor and sensor

4.2.1 Lower legform and sensor

4.2.1.1 Lower legform

- 4.2.1.1.1 Lower legform should consist of skin, flesh, femur, tibia and knee. The total mass of impactor is $13.2\text{kg} \pm 0.4\text{kg}$. See exterior dimension of impactor as per Figure 58 and Figure 59. From the point of view along Z-axis of legform, the cross-section of femur and tibia: the length is $90\text{mm} \pm 2\text{mm}$ along Y-axis direction; and the length is $84\text{mm} \pm 1\text{mm}$

along X-axis direction. The impacting face is an arc of radius $30\text{mm}\pm 1\text{mm}$, the length is $30\text{mm}\pm 1\text{mm}$ along Y-axis direction, and the length is $48\text{mm}\pm 1\text{mm}$ along X-axis direction. From the point of view along Z-axis of legform, the cross-section of knee: the length is $108\text{mm}\pm 2\text{mm}$ along Y-axis direction; and the length is $118\text{mm}\pm 1\text{mm}$ along X-axis direction. The impacting face is an arc of radius $103\text{mm}\pm 1\text{mm}$, the length is $12\text{mm}\pm 1\text{mm}$ along Y-axis direction and the length is $86\text{mm}\pm 1\text{mm}$ along X-axis direction.

4.2.1.1.2 The masses of the femur and tibia (without the flesh, but including the connection parts to the knee) should be $2.46\text{kg}\pm 0.12\text{kg}$ and $2.64\text{kg}\pm 0.13\text{kg}$ respectively. The mass of the knee (without the flesh) should be $4.28\text{kg}\pm 0.21\text{kg}$. The total mass of the femur, tibia and the knee should be $9.38\text{kg}\pm 0.47\text{kg}$. The centers of gravity of the femur and tibia (without the flesh, but including the connection parts to the knee) should be respectively $159\text{mm}\pm 8\text{mm}$ and $202\text{mm}\pm 10\text{mm}$ downwards from its top. The center of gravity of the knee should be $92\text{mm}\pm 5\text{mm}$ downwards from its top. The moment of inertia of the femur and tibia (without the flesh, but including the connection parts to the knee) about the X-axis through the respective centers of gravity should be $(0.0325\pm 0.0016)\text{ kg}\cdot\text{m}^2$ and $(0.0467\pm 0.0023)\text{ kg}\cdot\text{m}^2$ respectively. The moment of inertia of the knee about the X-axis through its center of gravity should be $(0.0180\pm 0.0009)\text{ kg}\cdot\text{m}^2$.

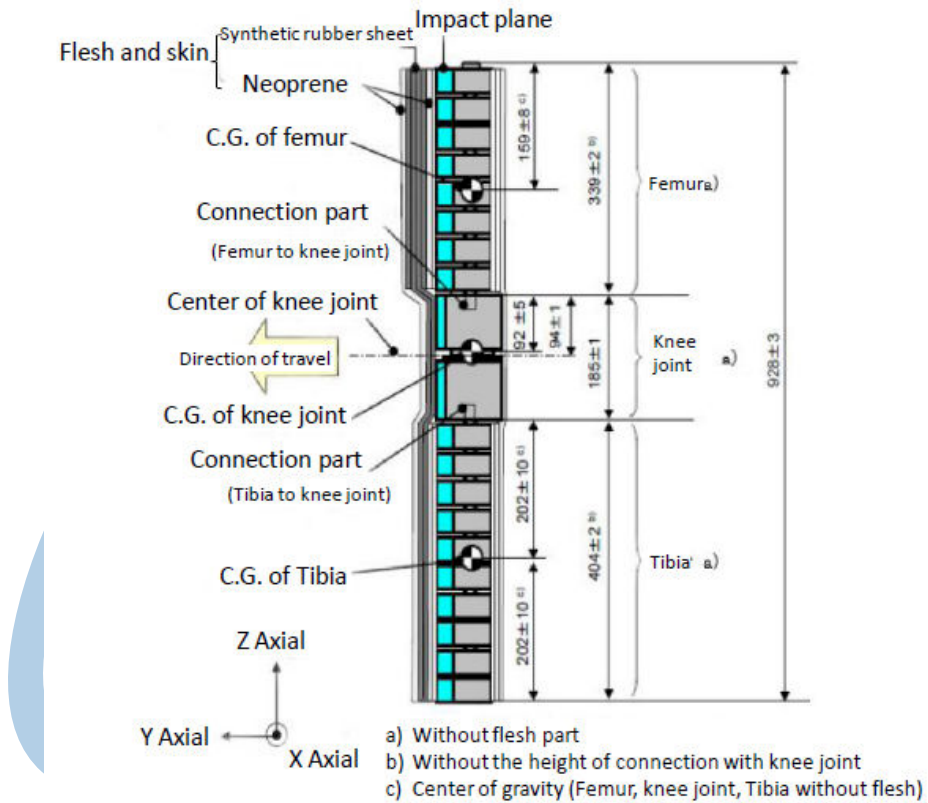

Figure 58 Dimension of lower legform structure

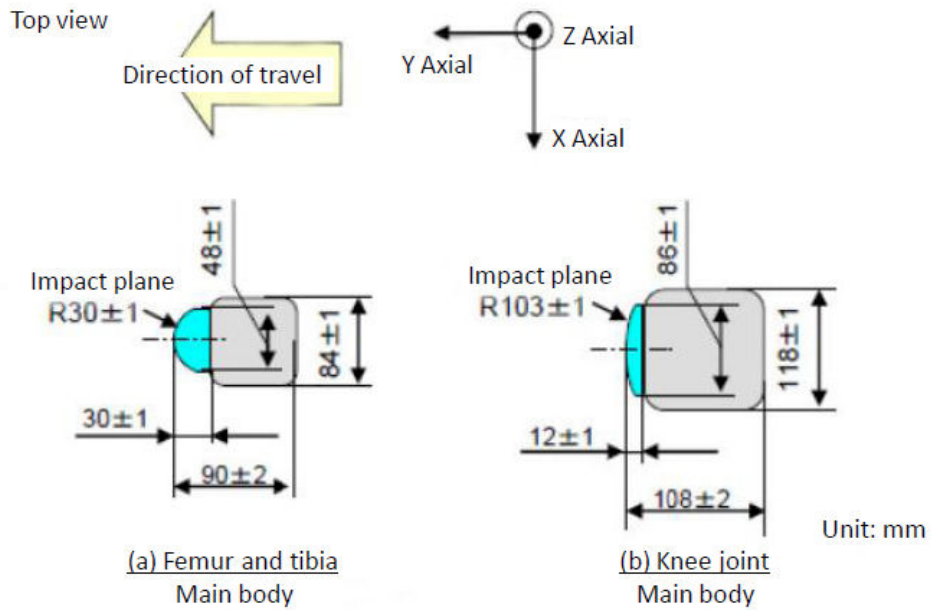

Figure 59 Top views of femur , tibia and knee

- 4.2.1.1.3 For each test, the impactor should be covered by flesh and skin composed of rubber sheets (R1 and R2) and nylon sheets (N1F, N2F, N1T, N2T and N3). The size of the rubber sheets and nylon sheets should meet the requirements described in Figure 60. The compression characteristics of rubber sheets and nylon sheets should meet the limit requirements in Figure 61. The compression characteristics of the same batch of material for the impactor flesh and skin should be checked.
- 4.2.1.1.4 All test impactor components should be stored in a storage area with constant temperature of $20^{\circ}\text{C}\pm 4^{\circ}\text{C}$ prior to use of impactor for testing. After removal from the storage area, the impactor should not be subjected to conditions other than those in the test zone.

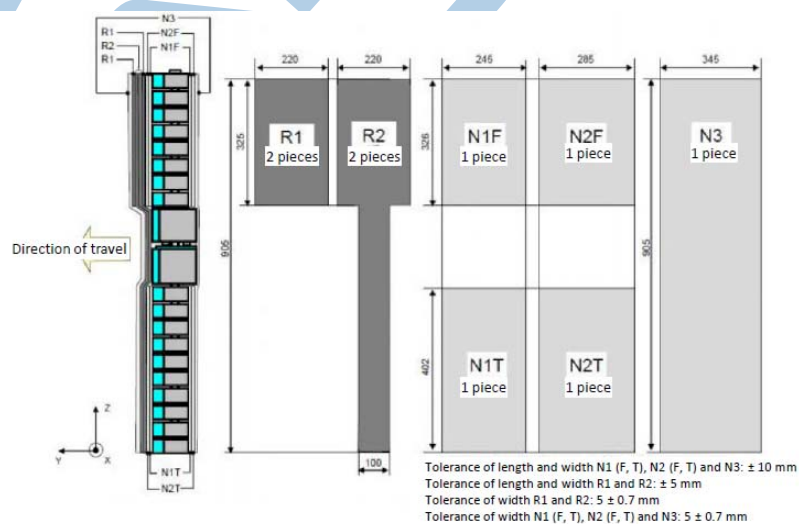
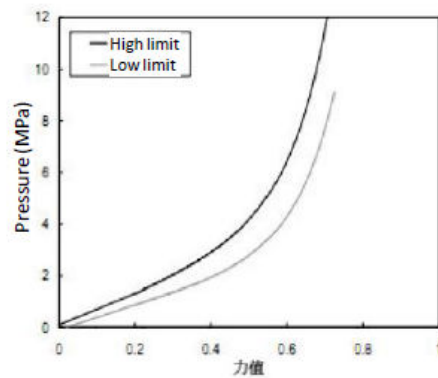

Figure 60 FLEX-PLI flesh and skin dimension

(a) Synthetic rubber sheet



(b) Neoprene

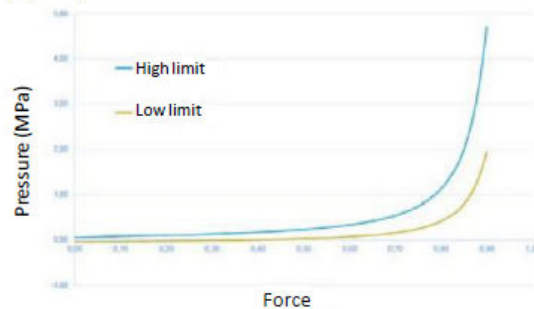

Figure 61 The compression limit requirements of rubber sheets and nylon sheets

4.2.1.2 Lower legform instrumentation

4.2.1.2.1 Four bending moment sensors should be installed on the lower leg. The distance between installation position of sensor and central position of knee joint: tibia-1: $134\text{mm}\pm 1\text{mm}$, tibia-2: $214\text{mm}\pm 1\text{mm}$, tibia-3: $294\text{mm}\pm 1\text{mm}$ and tibia-4: $374\text{mm}\pm 1\text{mm}$. Sensor measures the bending moment of X-axis of legform. As shown in Figure 62.

4.2.1.2.2 Sensors at knee position respectively measure elongations of MCL, ACL and PCL. The measurement locations at sensor side should be within the scope of $\pm 4\text{mm}$ along the X-axis from the knee center.

4.2.1.2.3 See definition of the instrumentation response value CFC (filter class) as per ISO 6487:2002, and CFC of all sensors should be 180. See definition of the CAC (channel amplitude class) response values as per ISO 6487:2002, knee ligament elongation should be 30mm and the lower leg bending moments should be 400Nm. This does not require that the impactor itself be able to reach the performance of the bending moment and elongation.

4.2.1.2.4 The lower leg bending moment and knee elongation peak value should be taken within the evaluation interval time. The lower legform evaluation interval refers to the specific time period from the moment of the 1st contact between lower legform impactor and vehicle to the moment of reduction of all bending moments of lower legform below 15Nm after reaching the maximum. Where the lower legform evaluation interval specified above does not exist in test result, it is necessary to reduce the lower legform bending moment in an overall manner.

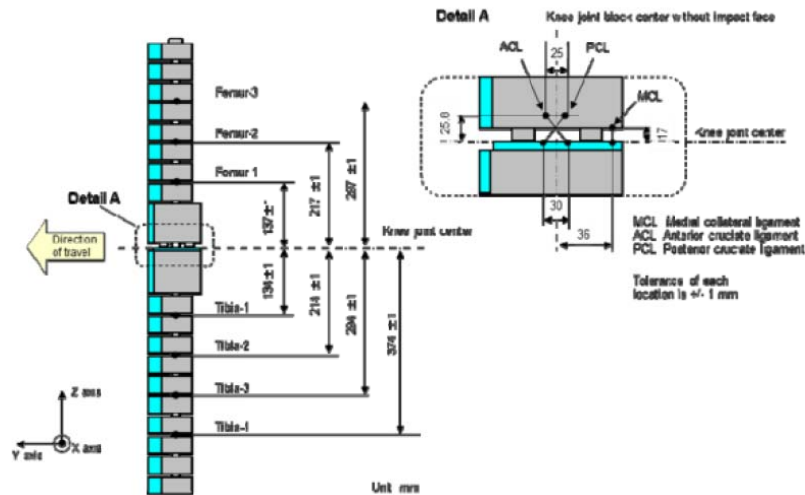

Figure 62 Diagram of FLEX-PLI instrument position

4.2.1.3 Calibration of lower legform

4.2.1.3.1 Calibration of lower legform uses dynamic impact calibration method.

4.2.1.3.2 When calibration test is performed for the headform impactor according to the stipulations of 4.2.1.4, the following requirements should be met:

The absolute value of the maximum bending moment of the lower leg should be not less than 230Nm and not more than 272Nm for bending moment 1, should be not less than 210Nm and not more than 252Nm for bending moment 2, should be not less than 166Nm and not more than 192Nm for bending moment 3 and should be not less than 93Nm and not more than 108Nm for bending moment 4.

The absolute value of knee ligament elongation should be not less than 17.0mm and not more than 21.0mm for MCL, should be not less than 8.0mm and not more than 10.0mm for ACL and should be not less than 4.0mm and not more than 6.0mm for PCL.

Above results should be acquired within 50ms starting from the impact moment.

4.2.1.3.3 Lower legform calibration period should be in compliance with the following stipulations.

4.2.1.3.3.1 After each time of calibration of lower legform, perform 10 impact tests at maximum.

4.2.1.3.3.2 After each time of calibration of lower legform, use for 12 months at maximum.

4.2.1.3.3.3 When lower legform exceeds CAC in test, it is necessary to calibrate again.

4.2.1.3.3.4 In each 12 months, lower legform should be subjected to one time of static calibration as per the use instruction manual of legform.

4.2.1.4 Lower legform calibration procedure

4.2.1.4.1 During calibration, ambient temperature should be $20^{\circ}\text{C} \pm 2^{\circ}\text{C}$, lower legform covered with the flesh and skin should be suspended vertically and freely from a test rig as shown in Figure 63.

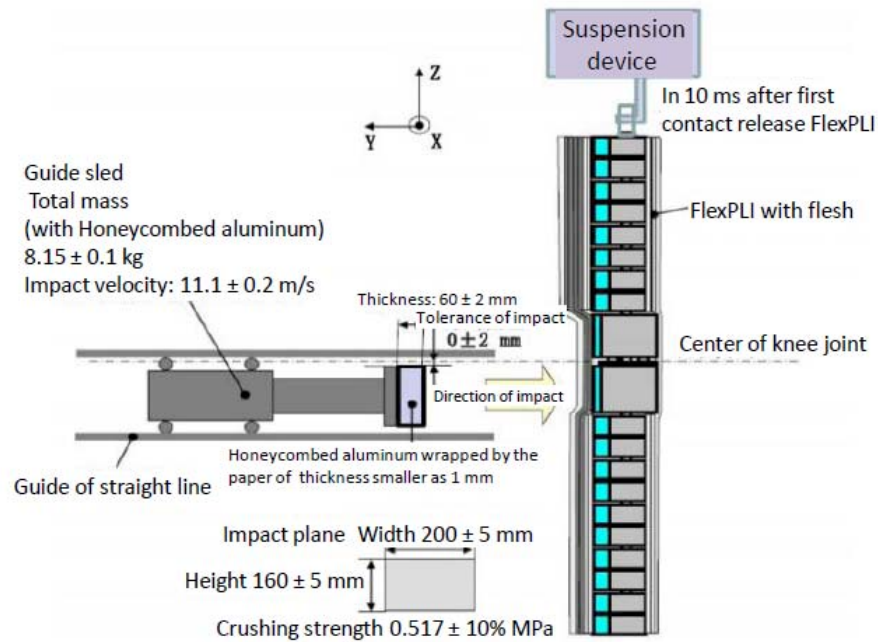

Figure 63 Dynamic impact calibration of lower legform

- 4.2.1.4.2 FLEX-PLI suspended freely is impacted by a linearly-guided aluminium honeycomb impactor at a speed of $11.1\text{ m/s} \pm 0.2\text{ m/s}$, and the surface of aluminium honeycomb is covered by a thin paper cloth with thickness not exceed 1mm. The legform should be under a free flight condition within 10ms after the time of the first contact with the aluminium honeycomb impactor.
- 4.2.1.4.3 The honeycomb of 5052 aluminium is attached in front of the moving impact device. The aluminium honeycomb should be $200\text{ mm} \pm 5\text{ mm}$ wide, $160\text{ mm} \pm 5\text{ mm}$ high and $60\text{ mm} \pm 2\text{ mm}$ thick and should have a crush strength of $0.517 \times (1 \pm 10\%) \text{ Mpa}$. The aluminium honeycomb should have cell sizes of 6.35 mm or 4.76 mm and a density of 36.8 kg/m^3 or 32 kg/m^3 respectively.
- 4.2.1.4.4 The upper edge of the aluminium honeycomb should be in line with the rigid plate of the linearly guided impactor. At the time of the first contact, the upper edge of the aluminium honeycomb should be in line with the knee center line within a vertical tolerance of $\pm 2\text{ mm}$. The aluminium honeycomb should not be deformed before the impact test.
- 4.2.1.4.5 At the time of the first contact, FLEX-PLI roll angle (rotation around the Y-axis) and the velocity vector of the aluminium honeycomb impactor should be within a deviation of $\pm 2^\circ$ in relation to the lateral vertical plane of vehicle. FLEX-PLI pitch angle (rotation around the X-axis) and the pitch angle of the aluminium honeycomb impactor should be within a deviation of $\pm 2^\circ$ in relation to the longitudinal vertical plane of vehicle. FLEX-PLI yaw angle (rotation around the Z-axis) and the yaw angle of the velocity vector of the aluminium honeycomb impactor should be within a deviation of $\pm 2^\circ$.

4.2.2 Upper legform and sensor

4.2.2.1 Upper legform impactor

The upper legform impactor should be rigid, foam covered at the impact side, and $350\text{ mm} \pm 5\text{ mm}$ long (see Figure 64).

4.2.2.1.1 The total mass of the upper legform impactor should be $9.5\text{ kg} \pm 0.1\text{ kg}$, including those propulsion and guidance components which are important part of the impactor during the impact.

4.2.2.1.2 The total mass of the front member and other components in front of the load sensor assemblies, together with those parts of the load sensor assemblies in front of the activation elements, but excluding the foam and skin, should be $1.95\text{ kg} \pm 0.05\text{ kg}$.

- 4.2.2.1.3 In the bumper test, the upper legform impactor should be mounted to the propulsion system by a torque limiting connecting piece and be insensitive to off-axis loading. The impactor should move only in the specified direction of impact when getting in contact with the vehicle and should be prevented from motion in other directions including rotation about any axis.
- 4.2.2.1.4 The torque limiting connecting piece should be set in such a way that the longitudinal axis of the front member is vertical at the time of impact with a deviation of $\pm 2^\circ$, with the connecting piece friction torque set to $675\text{Nm} \pm 25\text{Nm}$.
- 4.2.2.1.5 The center of gravity of those parts of the impactor which are forward of the torque limiting connecting piece, including all weights, should lie on the longitudinal center line of the impactor, with a deviation of $\pm 10\text{mm}$.
- 4.2.2.1.6 The length between the load sensor center lines should be $310\text{mm} \pm 1\text{mm}$ and the front member diameter should be $50\text{mm} \pm 1\text{mm}$.
- 4.2.2.1.7 For each time of test, impactor should be installed with two sheets of 25mm thick CF-45 type of foam flesh or equivalent, the foam flesh should be taken from material for dynamic calibration test. The skin should be 1.5mm thick fiber reinforced rubber layer. The total mass of foam and rubber skin should be $0.6 \pm 0.1\text{kg}$ (excluding any reinforcement and mounting components, etc which are used to attach the rear edge of rubber skin to the rear member). The foam and rubber skin should be folded towards the rear, with the rubber skin attached via spacers to the rear member so that the sides of rubber skin are held parallel. The foam should be of such size and shape to ensure that a sufficient gap is maintained between the foam and components behind the front member, so as to avoid significant load transfer between the foam and these components.

4.2.2.2 Upper legform instrument

- 4.2.2.2.1 It is necessary to use strain gauge to measure the bending moment of the front member in three positions, as shown in Figure 64, each position using a separate channel. The strain gauge should be installed behind the front component of impactor. Two outer strain gauges are located $50\text{mm} \pm 1\text{mm}$ from the impactor's symmetrical axis. The middle strain gauge is located on the symmetrical axis with a deviation of $\pm 1\text{mm}$.
- 4.2.2.2.2 Two load sensors should respectively measure the force applied on both sides of upper legform impactor, and strain gauge should respectively measure the bending moment at positions of center of upper legform impactor and two sides 50mm from center line.
- 4.2.2.2.3 See definition of the instrumentation response value CFC as per ISO 6487:2002, CFC of all sensors should be 180. See definition of the CAC response value as per ISO 6487:2002, force should be 10kN and bending moment should be 1,000Nm.

4.2.2.3 Calibration of upper legform

- 4.2.2.3.1 The upper legform impactor should meet the following requirements when it is calibrated and tested as specified in 4.2.2.4:

When the impactor impacts a stationary cylindrical pendulum tube, the peak load measured in each load sensor should be not less than 1.20kN and not more than 1.55kN, and the difference between the peak load measured in the top and bottom load sensors should be not more than 0.10kN. Similarly, the peak bending moment measured by strain gauges should be not less than 190Nm and not more than 250Nm on the center position, and the peak bending moment should be not less than 160Nm and not more than 220Nm for the outer positions. The difference between the upper and lower peak bending moment should be not more than 20Nm. For all these measured values, readings are taken during the initial impact with the pendulum tube and not from the stop process. For any device used to stop the impactor or pendulum tube, its stop process should not overlay with the initial impact process in term of time. The stopping device should not cause the sensor output to exceed the specified CAC value.

- 4.2.2.3.2 Calibration cycle of upper legform

- 4.2.2.3.2.1 After each time of upper legform calibration, perform 20 times of impact test at most.
- 4.2.2.3.2.2 After each time of upper legform calibration, use for 12 months at most.
- 4.2.2.3.2.3 When upper legform exceeds CAC in test, it is necessary to calibrate again.

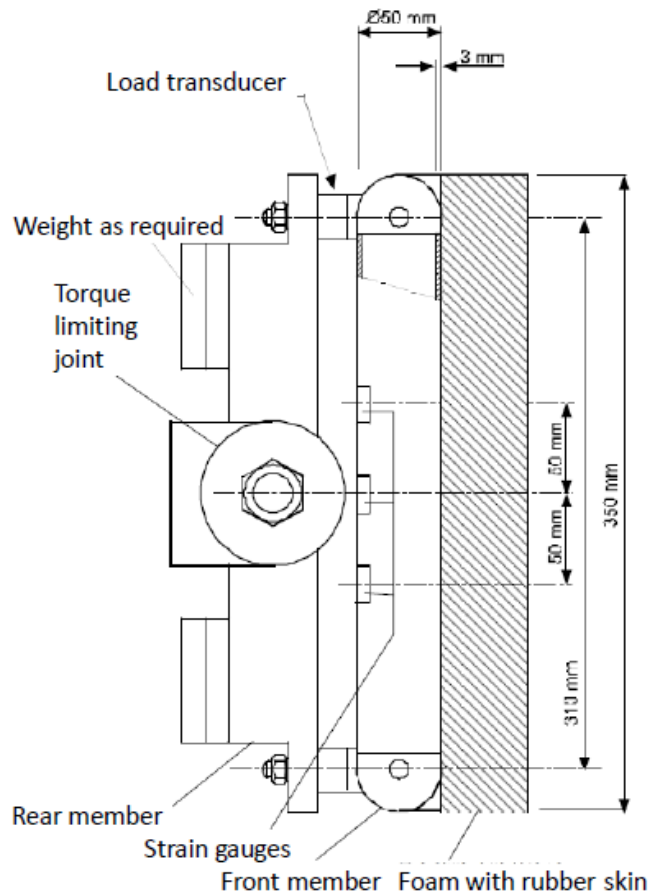

Figure 64 Upper legform impactor

4.2.2.4 Calibration procedure of upper legform

- 4.2.2.4.1 Before calibration test, test impactor should be kept in under-control storage area of constant humidity of $35\% \pm 10\%$ and constant temperature of $20^{\circ}\text{C} \pm 2^{\circ}\text{C}$ for at least 4h.
- 4.2.2.4.2 During the calibration test, test equipment should be kept under constant humidity of $40\% \pm 30\%$ and constant temperature of $20^{\circ}\text{C} \pm 4^{\circ}\text{C}$.
- 4.2.2.4.3 It is necessary to ensure that each time of calibration should be completed within 2h after taking the impactor from under-control storage area.
- 4.2.2.4.4 Impactor should be mounted to the propulsion device and guidance device by a torque limiting linkage point. The torque limiting linkage point should be set in such a way that the longitudinal axis of the front member of impactor is perpendicular to the guidance axis of the guidance device, with a deviation of $\pm 2^{\circ}$. The torque of torque limiting linkage point should be set to a scope of $675\text{Nm} \pm 25\text{Nm}$. The guidance device should ensure small friction during guiding process, so as to ensure that the impactor moves only in the specified direction when it is in contact with the pendulum.
- 4.2.2.4.5 The impactor mass should be adjusted to $12\text{kg} \pm 0.1\text{kg}$. The mass includes the mass of propulsion device and guidance device components which constitute effective mass of the impactor during impact.
- 4.2.2.4.6 The center of impactor including additional mass which are forward of the torque limiting linkage point should lie on the longitudinal centerline of impactor, with a deviation not

more than $\pm 10\text{mm}$.

- 4.2.2.4.7 The foam flesh of impactor should be free from extreme handling or deformation before, during or after the mounting process.
- 4.2.2.4.8 The impactor with the front member vertical should horizontally impact into the stationary pendulum tube at a speed of $7.1\text{m/s} \pm 0.1\text{m/s}$, as shown in Figure 65.
- 4.2.2.4.9 The mass of pendulum tube should be $3\text{kg} \pm 0.03\text{kg}$, wall thickness should be $3\text{mm} \pm 0.15\text{mm}$ and outside diameter should be 150^{+1}_{-4}mm . The total length of pendulum tube should be $275\text{mm} \pm 25\text{mm}$. The pendulum tube should be made from cold drawn seamless steel, the outer surface roughness should be better than $2.0\mu\text{m}$, it should be suspended on two steel wire ropes of diameter of $1.5\text{mm} \pm 0.2\text{mm}$ and length not less than 2.0m . The surface of pendulum should be clean and dry. The pendulum tube should be positioned to ensure that longitudinal axis of the cylinder is perpendicular to the front member of impactor (refer to horizontal), with a deviation of $\pm 2^\circ$; and is perpendicular to the motion direction of impactor, with a deviation of $\pm 2^\circ$. The center of the pendulum tube is aligned with the center of front part of the impactor, with a deviation of $\pm 5\text{mm}$ horizontally and vertically.

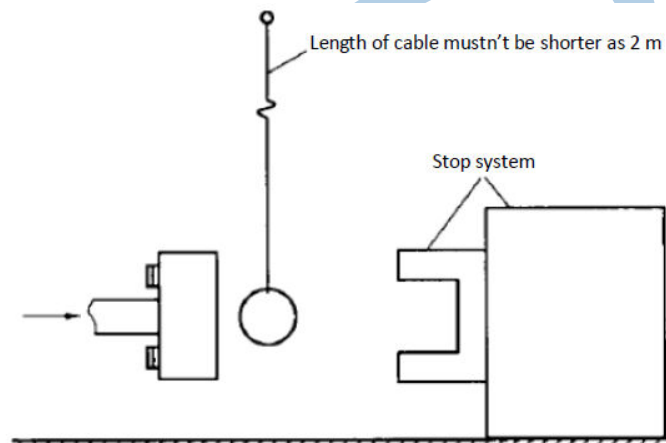

Figure 65 Dynamic calibration diagram of upper legform

4.3 Lower legform test procedure

- 4.3.1 Ensure that vehicle test preparation has been performed as per the requirements in section 1.
- 4.3.2 Ensure that vehicle is in normal ride attitude during the marking process.
- 4.3.3 Ensure that lower legform, vehicle, launch system and data acquisition system have been kept under temperature environment of 16°C - 24°C for at least 4h before test.
- 4.3.4 Adjust vehicle direction, so as to ensure that launch system launches lower legform in plane parallel to longitudinal median vertical plane of vehicle.
- 4.3.5 Adjust fore-aft position of vehicle, so as to ensure free flight distance of lower legform.
- 4.3.6 The bottom of the impactor should be $75\text{mm} \pm 10\text{mm}$ above ground reference plane at the time of the first contact. When setting the height of the recommended system, it is necessary to consider the influence of gravity during the period of free flight of the impactor. See Figure 66.
- 4.3.7 The velocity of the impactor when striking the bumper should be 40km/h . The impact speed should be acquired from measurement instrument at the time of the first contact. The accuracy of speed measurement device should at least reach $\pm 0.072\text{km/h}$.
- 4.3.8 The vector direction of the impact velocity should be in the horizontal plane and parallel to the longitudinal vertical plane of the vehicle. The deviation for the direction of the velocity vector in the horizontal plane and in the longitudinal plane should be not

exceed $\pm 2^\circ$ at the time of the first contact. The axis of the impactor should be perpendicular to the horizontal plane with deviation not exceed $\pm 2^\circ$ in the lateral plane and longitudinal plane. The longitudinal plane and lateral planes are orthogonal to each other.

- 4.3.9 The deviation of rotation angle of impactor around vertical axis should be not exceed $\pm 2^\circ$ in order to ensure accurate working of knee at the time of the first contact.
- 4.3.10 The lower leg bending moments should not exceed $\pm 10\text{Nm}$ in 30ms prior to impact.
- 4.3.11 At the time of the first contact, the deviation of spacing between center line of impactor and the selected test point should not exceed $\pm 10\text{mm}$. Laboratory may use multiple test measurement points to demonstrate that test meets the accuracy requirements specified above.
- 4.3.12 During contact between the impactor and the vehicle, the impactor should not contact the ground or any object which is not part of the vehicle.
- 4.3.13 Launch legform and start test.

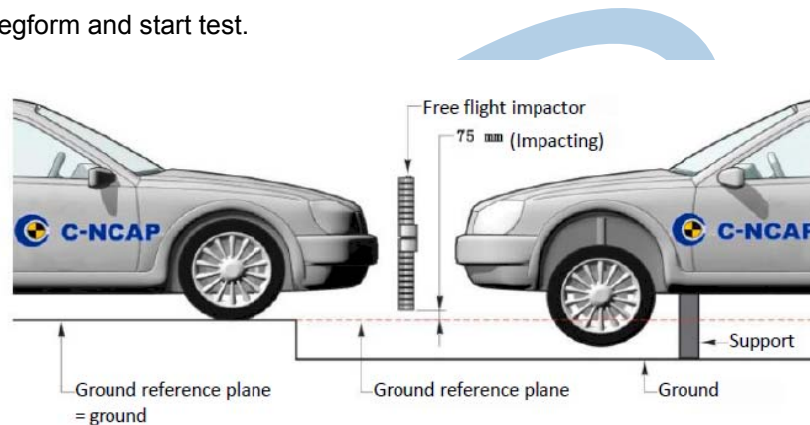

Figure 66 Test diagram of lower legform impacting vehicle

4.4 Upper legform test procedure

- 4.4.1 Ensure that vehicle test preparation has been performed as per the requirements in section 1.
- 4.4.2 Ensure that vehicle is in normal ride attitude during the marking process.
- 4.4.3 Ensure that upper legform, vehicle, launch system and data acquisition system have been kept under temperature environment of 16°C - 24°C for at least 2h before test.
- 4.4.4 The effective mass of upper legform impactor including propulsion and guidance components during impact should be $9.5\text{kg} \pm 0.1\text{kg}$. The mass of upper legform impactor can be adjusted in the scope of $\pm 1\text{kg}$ of the mass, and the speed should be adjusted correspondingly as per the following formula.

$$V = \sqrt{\frac{1170}{M}}$$

In which: V=collision speed (m/s)

M=mass (kg), measurement accuracy is more than $\pm 1\%$.

- 4.4.5 The total mass of the front member and other components in front of the load sensor assemblies excluding the foam and skin should be $1.95\text{kg} \pm 0.05\text{kg}$.
- 4.4.6 Install new flesh foam on upper legform, foam should be taken from one same piece of material of foam used in calibration test.
- 4.4.7 Adjust vehicle so that launch system aligns with impact position, and can guide and

launch upper legform along direction parallel to the center line of the vehicle, and the scope of tolerance should not exceed $\pm 2^\circ$. At the time of the first contact, the impactor center line should be midway between the upper bumper reference line and the lower bumper reference line with scope of tolerance of $\pm 10\text{mm}$, and the lateral deviation of the impactor center line in relation to impact point is within the scope of $\pm 10\text{mm}$.

- 4.4.8 The impact velocity of upper legform at the time of impact should be 40km/h. The accuracy of speed measurement device should at least reach $\pm 0.072\text{km/h}$. The influence of gravity acceleration should be taken into account for the velocity measured before the occurrence of contact.
- 4.4.9 Adjust fore-aft position of vehicle so that the required test speed is reached when impactor impacts vehicle, and the stop device on guide mechanism is not impacted during the impact with vehicle.
- 4.4.10 The direction of impact should be in horizontal plane and parallel to the longitudinal median plane of the vehicle. The upper legform axis should be kept vertical at the time of the first contact. The scope of deviation of impact direction from upper legform axis should not exceed $\pm 2^\circ$.
- 4.4.11 Launch impactor and start test.

5 Test of vehicles with deployable system

5.1 Preparation before test

- 5.1.1 For vehicle configured with deployable system. If it is necessary to assess deployable system under working condition, vehicle manufacturer should feedback description when receiving test notice of C-NCAP, and provide C-NCAP Administration Center with relevant data of deployable system required in this Chapter before the test begins.
- 5.1.2 Vehicle manufacturer should provide C-NCAP Administration Center with all information required in this test method, including working theory and working state information parameter of active bonnet system. C-NCAP Test Assessment Department determines whether to deploy the active bonnet system during test assessment as per the information provided by enterprise.
- 5.1.3 The data submitted should contain basic function information parameters of active bonnet system, along with parameters of sensing, trigger and deployment status.
- 5.1.4 In order to ensure completion of test as per plan, enterprise should submit sufficient data, including wearable parts replacement description, system trigger condition, health hazard details and components required for test, etc.
- 5.1.5 If active bonnet system data is not available or there is no sufficient information, or requirements of C-NCAP are not met, then active bonnet system will not be deployed during test of vehicle.

5.2 Detection of pedestrians

- 5.2.1 PDI2 can be used as the pedestrian dummy hardest-to-detect for assessment of verification of detection capability of active bonnet system, it is unnecessary to perform the demonstration of PDI2 hardest-to-detect as specified in 5.2.2. Perform test as per the stipulations of 5.2.3, and measure the total response time (TRT) of the active bonnet system, the total response time (TRT) of the active bonnet system equals sum of the sensing time (ST) of the active bonnet system and deployment time (DT) of the active bonnet system.
- 5.2.2 Where the vehicle manufacturer believes that the PDI2 is not appropriate to be used as the hardest-to-detect pedestrian dummy, manufacturer should demonstrate the sensing system's ability to detect pedestrian of different statures for whom active bonnet system provides protection. Pedestrian dummy of different statures can be 6 year old child dummy, 5th percentile female dummy, 50th percentile male dummy or 95th percentile

male dummy. A combination of physical testing and numerical simulations should be used to demonstrate the sensing system's ability to detect pedestrian of different statures.

- 5.2.2.1 Manufacturer can use the numerical simulation method to identify the hardest-to-detect (HTD) pedestrian dummy for active bonnet system and complete contents specified in 5.2.1 by using hardest-to-detect pedestrian dummy. The numerical simulation results should include the system detection response information for PDI2 and head impact time for dummy of different statures.
- 5.2.2.2 At least two numerical simulations should be performed for each dummy stature (not more than 8 times in total), so as to identify the hardest-to-detect (HTD) pedestrian and use it in test. Pedestrian dummy of different statures is specified in 5.2.2.
- 5.2.2.3 Vehicle manufacturer should state that dummy model is accurate and provide documentary evidence showing biofidelity and kinematics of the chosen dummy model.
- 5.2.2.4 The pedestrian stance should ensure that pedestrian will be facing in a direction perpendicular to the vehicle centerline with the two legs apart and the rearward leg being impacted by the bumper first. The distance between two feet (heel to heel) should meet the following requirements:
 6YO P=190±10mm;
 5th P=245±10mm;
 50th P=310±10mm;
 95th P=337±10mm.
 Similarly, it is necessary to simulate the outer contour of the bumper impacting leg first.
- 5.2.2.5 H-point height above ground when dummy model is in standing position with shoes is recommended to be:
 95th P: 1040mm±5%;
 50th P: 938mm±5%;
 5th P: 820mm±5%;
 6YO P: 610mm±5%.
- 5.2.2.6 The frictional factor between the foot and the ground surface should be set between 0.3±0.1.
- 5.2.2.7 During numerical simulations, select lower threshold impact speed with the active bonnet system deployed as defined by the vehicle manufacturer.
- 5.2.2.8 During numerical simulation of each dummy stature, it is necessary to select two different locations on the bumper, i.e., on the vehicle centerline and at the edge of the legform test zone.
- 5.2.2.9 Outputs results from numerical simulation should clearly indicate the detection capability of active bonnet system for pedestrian of different statures. The output parameters from the numerical simulations should at least include bumper force, effective mass, impact energy and bumper intrusion.
- 5.2.2.10 Effective mass should be calculated as per the following method. This calculation assumes that vehicle impact force is the maximum when the legform velocity is 0m/s:

$$M_e = \frac{\int_{t_1}^{t_2} F dt}{\Delta v}$$

In which: M_e =Effective mass (kg)

F =Impact force (N)

Δv =Change in velocity (m/s)

dt =Time increment (s)

t_1 =Time of first contact (s)

t_2 =Time of peak force (s)

5.2.2.11 In the event that the active bonnet system triggers before the impact force of cross member of bumper reaches the peak value, the calculation method is as follows:

$$M_e = \frac{\int_{t_1}^{t_2} F dt}{\int_{t_1}^{t_2} a dt}$$

In which: M_e =Effective mass (kg)

F =Impact force (N)

a =legform acceleration (m/s^2)

dt =Time increment (s)

t_1 =Time of first contact (s)

t_2 =Time of system trigger (s)

5.2.2.12 For the calculation of effective mass, only vehicle direction X is considered. The significant structures that act upon legform should be considered, such as the cross member of bumper and upper or lower support beams. Less significant structures such as grills may be ignored. Viscous effects can be ignored.

5.2.2.13 In accordance with form of the sensing system, select parameter that is suitable for description of hardest-to-detect pedestrian dummy information from the output result required in 5.2.2.9. Triggering parameter should be identical with active bonnet system detection time (DT).

5.2.3 Physical testing method should be used to verify the capability of active bonnet system for detection of pedestrian. During test, for a pedestrian dummy that is larger/heavier than a 50th percentile male dummy, lower legform impactor (FELX-PLI) can be used as substitution, so as to verify that active bonnet system can deploy normally when vehicle impacts larger stature pedestrians.

5.2.3.1 To ensure that vehicle is capable of detecting pedestrian effectively across the full bumper width, at least three verification tests should be performed in the legform test zone.

5.2.3.2 See the test program as per Table 35.

Table 35 Test program

Test	Impactor	Impact position	Speed	Output
1	PDI2 or HTD	① Sensor arrangement position ± 50 mm (for example, acceleration sensor). If the sensing system uses a combination of contact strip switch and acceleration sensor, impact the position of the acceleration sensor ② Vehicle center position: non-localized sensing systems (such as contact switches).	LT ± 2 km/h	1. High speed film; 2. Trigger time; 3. Initiation time of deployment
2	PDI2 or HTD	Legform test zone left or right side. Impact position deviation ± 50 mm.	LT ± 2 km/h	
3	PDI2 or HTD	Farthest position from sensor ± 50 mm (perform if not tested already at the position).	LT ± 2 km/h	

4*	FLEX-PLI and WG17	Sensor arrangement position $\pm 50\text{mm}$ (for example acceleration sensor) or position where it is easy to generate large acceleration for impactor (non-localized sensing systems).	40km/h \pm 2km/h	
Note: HTD: hardest-to-detect dummy; LT: Lower threshold speed. *The impactor for test 4 may be chosen by the vehicle manufacturer.				

5.2.3.3 At least test 3 should be witnessed or performed by C-NCAP to verify normal deployment of the active bonnet system at the lower threshold speed.

5.2.3.4 Test should be performed again where test speed is below the lower threshold speed or impact position is outside the legform test zone and the active bonnet system does not deploy. The test should ensure that test speed is not less than the lower threshold speed and impact position is not outside the legform test zone.

5.2.3.5 The results of all physical tests should at least include the following information:

- a) Good quality high speed film: showing the entire test process;
- b) Documentary evidence of the test location: using paint marks and taking photographs for record;
- c) The actual test speed: it is allowed to use speed measurement meter for record;
- d) Actuator trigger time (current clamp/ECU);
- e) Evidence of bonnet system deployment initiation, for example, high speed film showing the first movement of the bonnet top, etc.

5.2.3.6 During the first test, it is necessary to ensure that pedestrian protection system is fully functional from the sensing systems to the bonnet actuators/airbag squibs. During the first test, it is acceptable to mark system working condition by flashing light. If flashing light can accurately mark the moment of bonnet deployment or pedestrian airbag squib, and bonnet is deployed or pedestrian airbag is deployed normally, then other tests may use flashing light to verify whether system has actuation triggering signal.

5.3 Timing of system deployment

5.3.1 Grid points that are not affected by the active system should be tested statically.

5.3.2 Where vehicle manufacturer has demonstrated, by numerical simulations or other alternative means (vehicle speed of 45km/h), that system is fully deployed and remains in the intended position prior to the head impact time of the smallest stature pedestrian, then all headform tests can be performed with the bonnet in the fully deployed condition. There will be no need to trigger any active unit during tests, with the exception of pedestrian protection airbag.

5.3.3 Where the active system cannot be fully deployed in the head impact time (HIT) for pedestrian of a certain stature, grid points forwards of the corresponding wrap around distance should be tested dynamically. For all vehicles equipped with active system, manufacturer should provide relation diagram of wrap around distance and head impact test (HIT).

5.3.4 For active systems that cannot remain in a permanently deployed position, dynamic test should be performed.

5.3.5 Pedestrian should be positioned at vehicle center position as per the CAE model/code and pedestrian stance identical with those defined in 5.2.2 for numerical simulation analysis.

5.3.6 Vehicle manufacturer should determine the wrap around distance for each test location and the head impact time (HIT) for pedestrian of relevant stature. HIT corresponding to test point can be obtained through WAD vs HIT chart in appendix 3-2 by using linear interpolation method.

5.4 Protection of pedestrian against vehicle impact at lower threshold speed

5.4.1 When vehicle equipped with active bonnet system is below the lower threshold speed,

protection of pedestrian against impact should be provided too.

- 5.4.2 The headform test zone to be assessed includes all grid points that have a distance of 50mm or more inboard from the side reference lines and 50mm or less outward from bonnet shut line. The above distance is measured along vehicle Y-direction. See Figure 67.
- 5.4.3 The headform test zone to be assessed includes all grid points that are between WAD1000 and rear edge of the movable bonnet top. Child headform grid points are from WAD1000 to WAD1700 (including WAD1700) and adult headform grid points are rearward from WAD1700 rearward to the rear edge of the movable bonnet top.
- 5.4.4 Where only partial areas of the active bonnet system are to be tested under the completely deployed condition (depending on head impact time), then the headform test zone of consideration should be all grid points that are located between the rear edge of the movable bonnet top and 50mm forward from the front edge of test zone of the system that will be tested under the deployed condition.
- 5.4.5 The vehicle manufacturer should provide the C-NCAP Administration Center with HIC₁₅ value of headform test zone grid points or color distribution diagram. The provided data should indicate grid points that are predicted green, yellow or orange at 40km/h within the assessment area mentioned above and should produce HIC₁₅ values should not more than 1,350 at the lower threshold speed.
- 5.4.6 At lower threshold speed, for not less than 2/3 of grid points within the assessment area mentioned above, HIC₁₅ values should not exceed 1,000.
- 5.4.7 At lower threshold speed, color distribution diagram results data should be provided for each grid point according to the following determination criteria: HIC₁₅ < 1,000 = Yellow; 1000 < HIC₁₅ < 1,350 = Orange.
- 5.4.8 C-NCAP Test Evaluation Department should randomly select not more than three grid points to verify headform test result data provided by enterprise in the assessment area mentioned above at lower threshold speed.
- 5.4.9 Where vehicle under test/assessment cannot meet any requirement in 5.4.5-5.4.7, then tests should be performed with the active bonnet system under the undeployed condition.

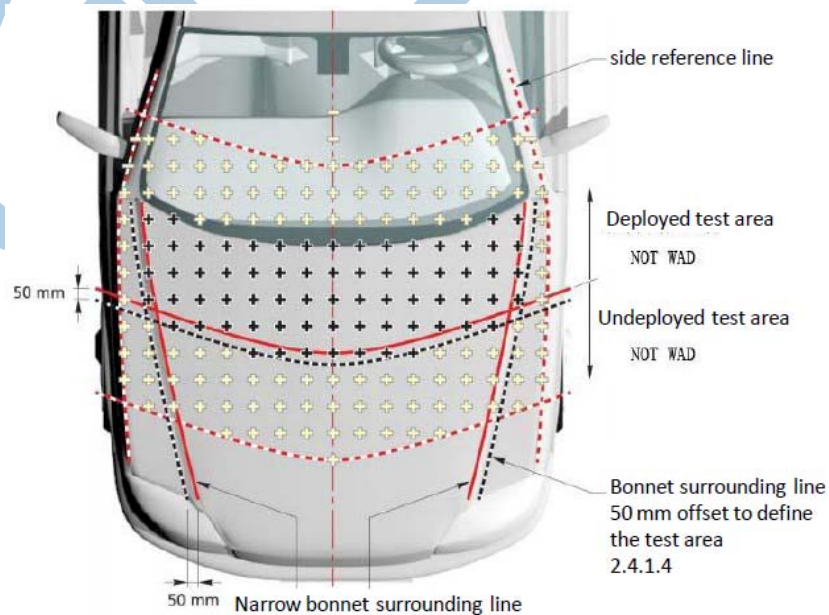

Figure 67 Area to meet low speed requirements

5.5 Protection of pedestrian against vehicle impact at high speed

- 5.5.1 All active bonnet systems should be capable of initiating at speed of 50km/h. Vehicle manufacturer should provide evidence to demonstrate that system can initiate at speed of 50km/h. It is not necessary for a system to be fully deployed before pedestrian head contacts bonnet when the active bonnet system initiates at speed of 50km/h.
- 5.5.2 When test is performed by using the impactor specified in 5.2 at speed of 50km/h, the active bonnet system should be capable of initiating, and the output results from the test should meet the requirements in 5.2.3.5.
- 5.5.3 The test should be performed at the vehicle center position. For vehicle installed with localized sensor (such as acceleration sensor), it is necessary to perform test as far away from the sensor as a possible in the legform test zone.
- 5.6 Bonnet deflection due to body loading**
- Peripheral support of active bonnet system is weak compared to passive bonnet systems, pedestrian head impact protection of vehicle should not be influenced by bonnet collapse.
- 5.6.1 Measure and compare the Z-direction deflection at the position of headform impact for both a deployed and undeployed bonnet at the time of first headform contact. At the position of headform impact, the deflection difference between deployed and undeployed bonnet should be not more than 75% of deployment height at the position, see Figure 68.
- 5.6.2 Bonnet deflection can be evaluated by using CAE calculation method, CAE model should not include engine and ancillaries, but should include white body structure, bonnet support structure and all components that support pedestrian legs and pelvis of pedestrian.
- 5.6.3 Deflection at the point of headform impact under the deployed condition of bonnet should not exceed the valid clearance between deployed bonnet and under bonnet hard point. For example, $(h_2 + h_3) - z_2 > 0$, see Figure 69.
- 5.6.4 It is necessary to perform numerical simulations at 40km/h. It is necessary to select dummy of the appropriate size that loads the least support of the bonnet top in accordance with particular size of vehicle. For example, on a small vehicle with a short bonnet, the 50th percentile dummy contacts the vehicle rearward of the bonnet top. Therefore, dummy of smaller stature should be used.
- 5.6.5 Position the pedestrian's head on the vehicle centerline as per the stance of dummy described in 2.2.3.1.4.

1. Simulation of undeployment: 40 km/h, center line, walking posture, 50th % dummy
(if no contact between bonnet and 5th % dummy)

All the dimensions are measured by first contact between head and impact point

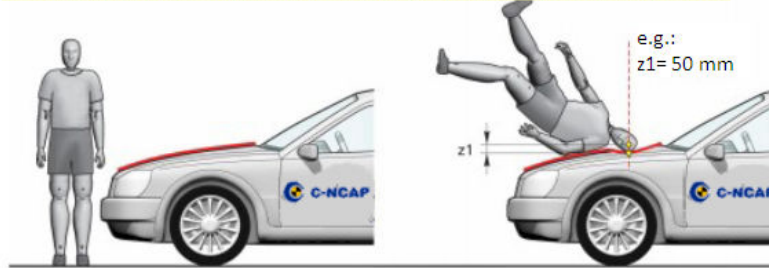

Output:

- a. Displacement of head contact point in Z axial: z1
- First moment of head contact

2. Simulation of deployment: 40 km/h, center line, walking posture, 50th % dummy
(if no contact between bonnet and 5th % dummy)

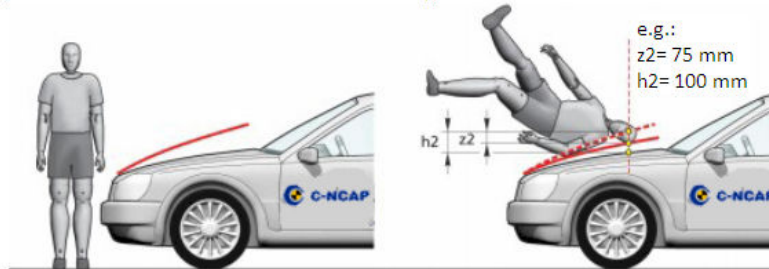

Output:

- b. Displacement in Z axial: z2
- c. Height of deployment: h2

3. Requirement:
 $z2 - z1 < 75\% \times h2$

E.g.:
 $75 \text{ mm} - 50 \text{ mm} < 75\% \times 100 \text{ mm}$
 $25 \text{ mm} < 75 \text{ mm} (= \text{OK})$

Deformation of deployed bonnet (z2) shouldn't exceed the sum of deformation of undeployed bonnet (z1) and 75% of the height of deployment (h2).

Figure 68 Comparison between deployed and undeployed bonnet deflection

Simulation: 40 km/h, center line, walking posture, 50th % dummy
(if no contact between bonnet and 5th % dummy)

All the dimensions are measured by first contact between head and impact point

z2: Vertical displacement acting on the bonnet
h2: height of deployment on head impact point

h3: Distance from undeployed bonnet to hard point under the bonnet on head impact point

Package requirements
 $(h2 + h3) - z2 > 0$

e.g.:
 $(100 \text{ mm} + 30 \text{ mm}) - 75 \text{ mm} = 55 \text{ mm}$
 $55 \text{ mm} > 0 \text{ mm} (= \text{OK})$

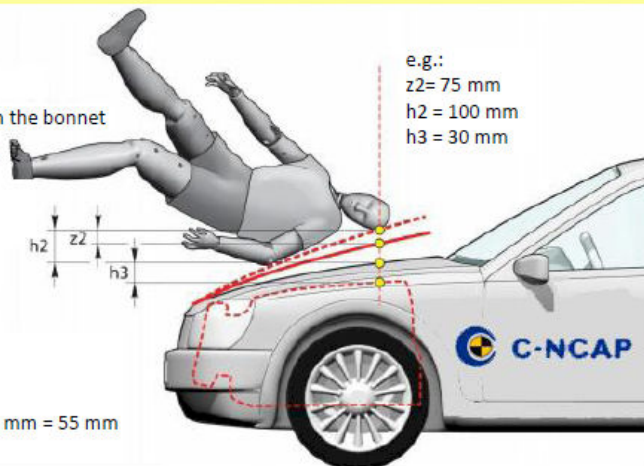

Figure 69 Bonnet deflection requirement

Chapter VI Test of Autonomous Emergency Braking System (AEB) of Vehicle

1 Terms and definitions

PBC (Peak Braking Coefficient): the measure of tyre to road surface friction based on the maximum deceleration of a rolling tyre, as measured on dry road surface in accordance with the stipulations of Chapter 6 of GB/T 26987-2011; as alternative, it can also be determined as per the method of 5.6.4 in GB 21670-2008.

AEB (Autonomous Emergency Braking): braking that is applied automatically by the vehicle in response to the detection of a likely collision to reduce the vehicle speed and potentially avoid the collision.

FCW (Forward Collision Warning): a warning that is sent automatically by the vehicle in case of the detection of a likely collision to alert the driver.

DBS (Dynamic Brake Support): in case driver has already performed braking operation and a potential collision is still detected, the system will automatically adjust braking force to achieve a greater vehicle deceleration than would be achieved by the same driver braking input in normal driving conditions.

VUT (Vehicle Under Test): the vehicle that is configured with AEB or FCW and is tested according to this test protocol.

VT (Vehicle Target): the vehicle target specified to be used in this test protocol.

PTA (Pedestrian Target Adult): the adult dummy target specified to be used in this test protocol.

DLV (Deceleration Lead Vehicle): the vehicle target that is braking on adjacent lane under adjacent lane vehicle braking test.

MLV (Moving Lead Vehicle): moving vehicle target on subject lane under adjacent lane vehicle braking test.

HMI: Human Machine Interface.

TTC (Time To Collision): the time taken for VUT to strike the VT or PTA while maintaining the current motion conditions unchanged.

CCRs (Car to Car Rear Stationary): a scenario in which VT is stationary and the frontal structure of rear vehicle strikes the rear structure of lead vehicle.

CCRm (Car to Car Rear Moving): a scenario in which VT is moving slowly at constant speed and the frontal structure of rear vehicle strikes the rear structure of lead vehicle.

CCRb (Car to Car Rear Braking): a scenario in which VT and VUT are travelling at same speed and maintain constant speed, then lead vehicle applies brake, and the frontal structure of rear vehicle strikes the rear structure of lead vehicle.

VRU: Vulnerable Road Users.

CVFA-50 (Car-to-VRU Farside Adult): a scenario in which a vehicle impacts an adult pedestrian crossing from the farside and the impact position is at 50% of frontal structure of the vehicle when no braking action is applied.

CVFA-25 (Car-to-VRU Farside Adult): a scenario in which a vehicle impacts an adult pedestrian running from the farside and the impact position is at 25% of frontal structure of the vehicle when no braking action is applied.

CVNA-25 (Car-to-VRU Nearside Adult): a scenario in which a vehicle impacts an adult pedestrian crossing from the nearside and the impact position is at 25% of frontal structure of the vehicle when no braking action is applied.

CVNA-75 (Car-to-VRU Nearside Adult): a scenario in which a vehicle impacts an adult pedestrian crossing from the nearside and the impact position is at 75% of frontal structure of the vehicle when no braking action is applied.

X_{VUT} , Y_{VUT} : Real-time position coordinate of the VUT during the test.

X_{VT} , Y_{VT} : Real-time position coordinate of the VT during the test.

Y_{PTA} : Position of the PTA during the test.

V_{VUT} : Real-time speed of the VUT during the test.

V_{VT} : Real-time speed of VT during the test.

V_{PTA} : Real-time speed of PTA during the test.

T_{AEB} : Activation time is determined by identifying the last data point where the filtered acceleration signal is below -1 m/s^2 , and then going back to the point in time where the acceleration first crossed -0.3 m/s^2 .

T_{FCW} : the time when the FCW sends audible warning. The moment is the moment when sound receiver detects FCW warning.

V_{test} : Test speed of VUT.

V_{impact} : The speed of VUT at which the VUT impacts the VT/PTA.

$V_{rel,test}$: the stable relative speed ($V_{VUT}-V_{VT}$) between VUT and VT at the moment when test starts. (CCRB: $V_{rel,test}$ is the initial speed of VUT).

$V_{rel,impact}$: The relative speed ($V_{VUT}-V_{VT}$) between VUT and VT when the VUT impacts the VT.

T_0 : T_0 is the moment of $TTC=4s$ (CCRB, T_0 is the moment when VT starts deceleration).

T_{impact} : The moment when collision between VUT and VT/PTA occurs.

V_{DLV} : The speed of DLV adjacent lane vehicle braking test.

V_{MLV} : The speed of MLV in adjacent lane vehicle braking test.

2 Test of autonomous emergency braking system (AEBCCR) in rear collision of vehicle

2.1 Coordinate system of vehicle

Both VUT and VT adopt the inertia coordinate system specified in ISO 8855:1991, in which the x-axis points towards the front of the vehicle, the y-axis points towards the left side of driver and the z-axis points upwards (right hand coordinate system). Viewed from the origin to positive direction of x, y and z axes, roll, pitch and yaw angles are to rotate clockwise around the x, y and z axes respectively. This reference system should be used for both left hand drive vehicles and right hand drive vehicles tested.

2.2 Lateral offset

The lateral offset refers to the horizontal distance between the center of the front of the VUT (or the rear of the VT) and the planned route. Figure 70 shows the schematic diagram of deviation at the VUT side and deviation at the VT side.

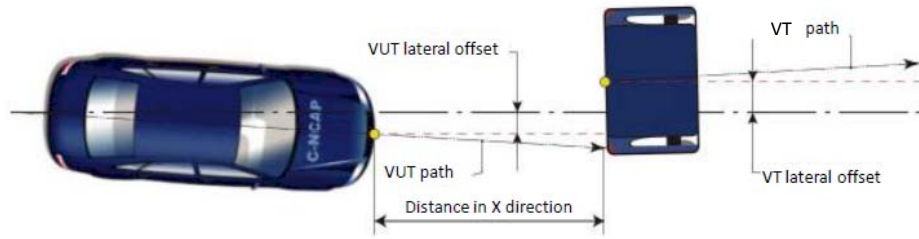

Figure 70 Lateral offset

2.3 Test equipment and vehicle target

2.3.1 Test equipment

2.3.1.1 Test equipment should be capable of sampling and storage of dynamic data, the frequency of sample and storage should be at least 100Hz. Synchronize data by using the DGPS time between VT and VUT.

2.3.1.2 The accuracy of data acquisition and record equipment in test process of VUT and VT should at least meet the following requirements.

- a) The accuracy of VUT and VT speed should be 0.1km/h;
- b) The accuracy of lateral and longitudinal position of VUT and VT should be 0.03m;
- c) The accuracy of VUT and VT yaw rate should be 0.1°/s;
- d) The accuracy of longitudinal acceleration of VUT and VT should be 0.1m/s²;
- e) The accuracy of VUT steering wheel angular velocity should be 1.0°/s;

2.3.2 Data filtering

2.3.2.1 Position and speed adopt original data and are not filtered.

2.3.2.2 Acceleration is filtered with a 12-pole phaseless Butterworth filter with a cut off frequency of 10Hz;

2.3.2.3 Yaw rate is filtered with a 12-pole phaseless Butterworth filter with a cut off frequency of 10Hz;

2.3.2.4 Pedal force is filtered with a 12-pole phaseless Butterworth filter with a cut off frequency of 10 Hz;

2.3.3 Vehicle target requirements

2.3.3.1 VT is used to replace actual M1 passenger vehicle (including visual, radar, LIDAR and PMD attributes), and can withstand impact at speed up to 50km/h without causing damage to the VUT and EVT.

2.3.3.2 Requirements regarding VT specification are identical with requirements of Euro-NCAP, see "Euro-NCAP TEST PROTOCOL-AEB systems Version 1.1 June 2015 ANNEX A EVT SPECIFIC ATIONS". Label of "Jin CATARC" logo is affixed on vehicle nameplate of VT, as shown in Figure 71.



Figure 71 Diagram of C-NCA PVT appearance

2.3.3.3 When a manufacturer believes that the VT cannot meet the requirements of VUT sensor on target, please contact the C-NCAP Administration Center directly.

2.4 Test conditions

2.4.1 Test track requirements

2.4.1.1 Test road surface is required to be dry, free from visible moisture on the surface, flat and solid, with a consistent gradient between level and 1%. The peak braking coefficient should be more than 0.9;

2.4.1.2 The test road surface is required to be paved and may not contain any irregularities (such as large dips or cracks, manhole covers or reflective studs, etc) that may cause abnormal sensor work. Width from lane center line to either side of road should be not less than 3.0m. A distance of at least 30m should be reserved on road ahead of the test end point; as shown in Figure 72.



Figure 72 Scope of test zone

2.4.1.3 Lane marking line is allowed for test road, but in the area of AEB activation and braking area after FCW alarm, it is necessary to ensure that lane marking line does not cross test trace.

2.4.2 Requirements on test weather

2.4.2.1 Weather is dry and there are no situations such as precipitation and snowfall, etc;

2.4.2.2 Visibility along horizontal direction should be not less than 1km;

2.4.2.3 Wind speed should be not more than 10m/s;

2.4.2.4 For test performed under natural light condition, illumination should be homogenous in the entire test zone and intensity of illumination should be not less than 2,000 lux. There

should be no strong shadow in the entire test zone other than those caused by the VUT and VT. Testing should not be performed along the direction towards or away from direct sunlight.

2.5 VUT preparation work

2.5.1 Tyre condition confirmation

Perform the testing with brand new original tyres identical with the tyre configurations (supplier, model, size, speed and load rating) specified by the vehicle manufacturer. It is permitted to replace the tyres which are supplied by the manufacturer or dealer specified by the manufacturer with those tyres identical with tyre configurations (supplier, model, size, speed and load rating) specified by the vehicle manufacturer. Inflate the tyres to the vehicle manufacturer's recommended cold-state tyre inflation pressure, and the cold-state pressure at least applies to normal loading condition.

2.5.2 Confirmation of complete vehicle condition

2.5.2.1 Fill up the tank with fuel to at least 90% of the fuel tank's capacity.

2.5.2.2 Check the oil/water of the complete vehicle and top up to its maximum level if necessary.

2.5.2.3 Ensure that the vehicle has its spare wheel on board (if fitted) along with any tools supplied with the vehicle. Nothing else should be in the vehicle.

2.5.2.4 Ensure that all tyres are inflated according to tyre pressure recommended by manufacturer for the current loading condition.

2.5.2.5 Measure the front and rear axle load of the vehicle and calculate the total mass of the vehicle, take the weight as the kerb mass and make record.

2.5.3 Running-in of brake system

Driving at an initial speed of 80km/h applies brake at deceleration of 3m/s^2 until stopped, repeat the process for 200 times. The initial braking temperature is 65°C - 100°C , and cool down to 65°C - 100°C or run for 2km before each braking.

2.5.4 Equipment mounting and loading

2.5.4.1 Fit test equipment and instrumentation.

2.5.4.2 Load vehicle as per the loading mass requirements (subtracting the mass of the test driver and test equipment from 200kg) and fasten.

2.5.4.3 Measure the front and rear axle loads of vehicle under condition where driver is included.

2.5.4.4 Compare it with the kerb mass of vehicle.

2.5.4.5 The difference between the total measured vehicle mass and the sum of the kerb mass plus 200kg should be within $\pm 1\%$, and the difference between front/rear axle load distribution and axle load distribution of the kerb mass plus full fuel load should be less than 5%. If the actual situations of vehicle differ from the requirements, loading should be adjusted provided that there is no influence on vehicle performance. And ensure firm attachment after adjustment.

2.5.4.6 Repeat 2.5.4.3-2.5.4.5 until the front and rear axle loads of vehicle and the total mass reach the requirements in 2.5.4.6. Care needs to be taken when adjusting load to approximate the original vehicle properties as close as possible, and record the final axle load.

2.6 Test procedure

2.6.1 VUT test preconditioning

2.6.1.1 Setup of AEB function and FCW function

Set any driver configurable elements of the AEB and/or FCW system (e.g. the timing of the collision warning or the braking application if present) to the middle setting or midpoint and then next latest setting similar to the examples shown in Figure 73.

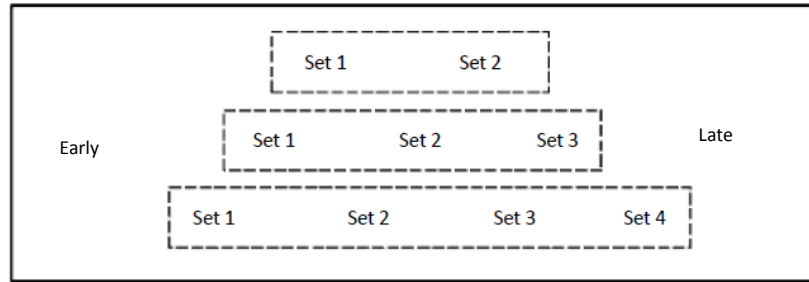

Figure 73 Setup of AEB/FCW system

2.6.1.2 Active bonnet system

When vehicle is installed with “active bonnet system”, turn off the system before test.

2.6.1.3 Brake conditioning before test

2.6.1.3.1 Apply brake and stop vehicle for totally 10 times from initial speed of 56km/h with an average deceleration of 0.5g-0.6g.

2.6.1.3.2 After completion of the series braking at initial speed of 56km/h, totally perform 3 stops of vehicle from initial speed of 72km/h by applying brake with full force.

2.6.1.3.3 When applying brake as specified in 2.6.1.3.2, it is necessary to apply sufficient force to the brake pedal so that ABS of vehicle is under operation condition for the majority of each stop process.

2.6.1.3.4 After completion of the final braking in 2.6.1.3.2, drive the vehicle at a speed of 72km/h for 5min to cool the brakes.

2.6.1.3.5 Test should begin within two hours after completion of the brake preparation.

2.6.1.4 Tyre conditioning prior to test

2.6.1.4.1 Drive the test vehicle around a circle of 30m in diameter clockwise for 3 laps, then drive for 3 anticlockwise laps; the driving speed should generate a lateral vehicle acceleration of approximately 0.5g-0.6g.

2.6.1.4.2 Perform a sinusoidal steering input at a frequency of 1Hz and a vehicle speed of 56km/h, so that vehicle generates a peak lateral acceleration of 0.5g-0.6g. Totally perform 4 times of test, and each time of test consists of 10 sinusoidal cycles.

2.6.1.4.3 During the last sinusoidal cycle of the final test, the steering angle amplitude should double that of other cycles. The allowable maximum time interval between all tests is 5min.

2.6.1.5 AEB/FCW system check

Before testing begins, perform a maximum of 10 tests at the lowest vehicle speed triggered by the system, so as to ensure proper functioning of the system.

2.6.2 Test scenarios

2.6.2.1 Test scenario of AEB CCR system performance

There are three test scenarios for the performance of the AEB CCR system: CCRs, CCRm and CCRb. As shown in Figure 74a), Figure 74b) and Figure 74c) as follows.

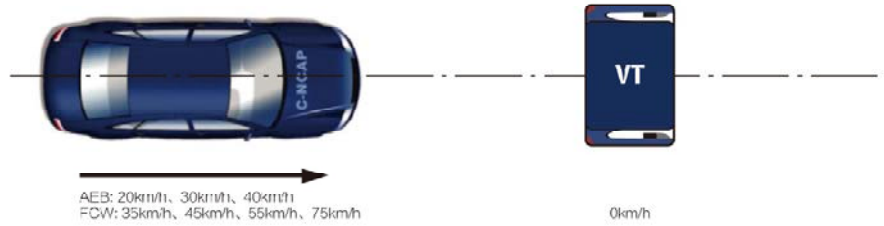

Figure 74a) CCRs scenario

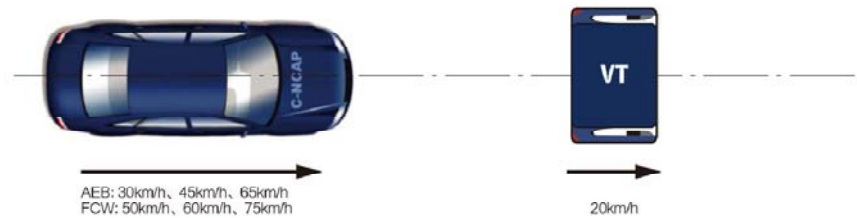

Figure 74b) CCRm scenario

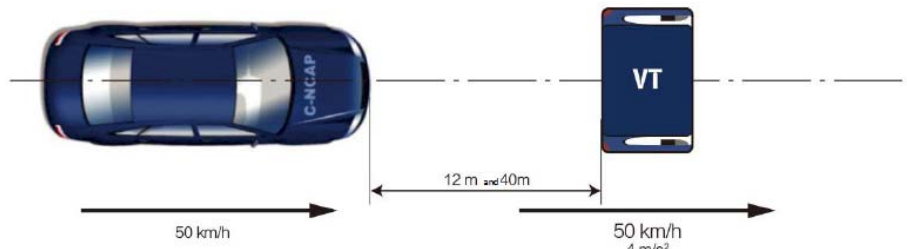

Figure 74c) CCRb scenario

CCRs: Place VT on VUT running route, and drive VUT along the planned route, as shown in Figure 74a). Test AEB function of VUT respectively at speed of 20km/h, 30km/h and 40km/h, and test FCW function at speed of 35km/h, 45km/h, 55km/h and 75km/h.

CCRm: Drive VUT and VT along the planned route, as shown in Figure 74b). VT travels at constant speed of 20km/h, test AEB function of VUT respectively at speed of 30km/h, 45km/h and 65km/h, and test FCW function at speed of 50km/h, 60km/h and 75km/h.

CCRb: Drive VUT and VT at speed of 50km/h along the planned route, headway should be respectively 12m and 40m, as shown in Figure 74c). The deceleration of VT should reach 4m/s² within 1s and error should not exceed $\pm 0.25\text{m/s}^2$ until the end of test.

2.6.2.2 Test scenario of AEB CCR system false reaction

2.6.2.2.1 Adjacent lane vehicle braking test

Test consists of three units of vehicle of VUT, MLV and DLV, of which the vehicle speed is 40km/h. Keep the distance between outer edge of tyre and mid lane within the scope of (0.9 ± 0.1) m, and keep parallel running of MLV and DLV, as shown in Figure 75. After keeping the distance between head of VUT and tail of MLV within (15 ± 1.2) m for at least 3s, apply brake of DLV at deceleration of (3 ± 0.3) m/s².

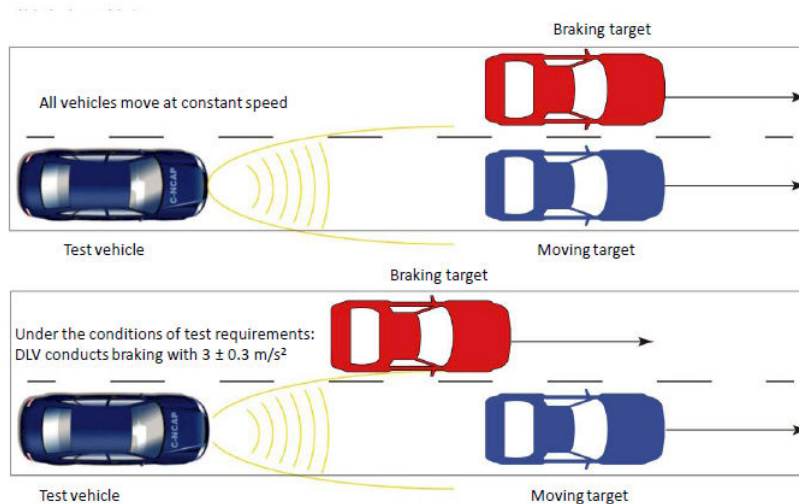

Figure 75 Adjacent lane vehicle braking test

2.6.2.2.2 Iron plate test

Drive VUT respectively at constant speeds of 40km/h and 72km/h towards steel plate placed on test road. The dimension of steel plate is 2.4m×3.7m×0.025m, and vehicle running route is identical with center line of lengthwise direction of steel plate.

If FCW warns in this test, then apply braking force mentioned in 2.8 of this Chapter and add comparison test.

Comparison test method: under condition without iron plate, drive VUT at the same speed, and apply brake force as per 2.8 of this chapter. Compare the deceleration of vehicle in two tests and determine whether DBS gets involved.

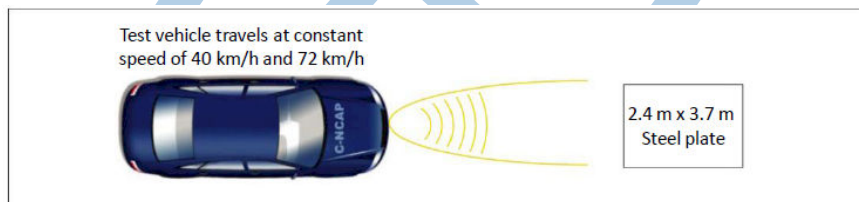

Figure 76 Iron plate test

2.6.2.3 Summary of AEB CCR test scenario

Table 36 is a summary of AEB CCR test scenario, when performing FCW system test, apply brake 1.2s after T_{FCW} . The braking characteristic curve is provided by manufacturer and braking input is completed within 200ms, the maximum velocity is 400mm/s, under circumstances other than emergency braking, the generated braking deceleration is within the scope from $-4m/s^2$ to $-4.25m/s^2$. If the deceleration exceeds the scope or manufacture does not provide braking characteristic curve, apply braking force as per the process in 2.8 of this chapter.

Table 36 AEB CCR test scenario

Test items	Test scenarios						Misuse	
	CCR _s		CCR _m		CCR _b		Adjacent lane vehicle braking test	Iron plate test
	AEB	FCW	AEB	FCW	AEB	FCW		
Vehicle speed	20km/h	35km/h	30km/h	50km/h	50km/h (12m, 4m/s ²)	50km/h (12m, 4m/s ²)	40km/h	40km/h
	30km/h	45km/h	45km/h	60km/h				
	40km/h	55km/h	65km/h	75km/h				
		75km/h						
				50km/h (40m, 4m/s ²)	50km/h (40m, 4m/s ²)		72km/h	

2.6.3 Test requirements

2.6.3.1 Gear selection and vehicle control

For vehicles with an automatic transmission, select gear D. For vehicles with a manual transmission, engage the highest gear of transmission where engine speed reaches at least 1,500RPM at the test speed. A speed limiting device or cruise device on VUT may be used to maintain the test vehicle speed, unless the vehicle manufacturer indicates that these functions influence the AEB system work. It is allowed to turn steering wheel slightly to keep VUT to run along the planned route if necessary.

2.6.3.2 Time interval

Start the first test within 90s-10min after completing the tyre preparation, and the time interval between end of each test and start of the subsequent test is also 90s-10min. If the time interval exceeds 10min, it is necessary to perform tyre and braking conditioning again. In the test interval, unless special circumstance seriously influences vehicle safety, speed of VUT should not exceed 50km/h, and harsh acceleration, deceleration and steering operation should be avoided.

2.6.3.3 Test accuracy

Accelerate VUT and VT (if necessary) to the required test vehicle speed. Test should meet the following conditions within time scope between T_0 and T_{AEB}/T_{FCW} :

- a) V_{VUT} (GPS speed): test vehicle speed + 1.0km/h;
- b) V_{VT} (GPS speed): test vehicle speed \pm 1.0km/h;
- c) Lateral deviation: 0 ± 0.1 m;
- d) Relative distance between VUT and VT (CCRb scenario): 12m/40m \pm 0.5m;
- e) Yaw velocity: $0\pm 1.0^\circ$ /s;
- f) Steering wheel turning velocity: $0\pm 15.0^\circ$ /s;

Remarks: In CCRb scenario, the "VT speed" and "relative distance between VUT and VT" are only inspected for the moment T_0 .

2.6.3.4 Conditions for end of single test

Test ends when one of the following conditions occurs:

- a) $V_{VUT}=0$ km/h;
- b) $V_{VUT}<V_{VT}$, and there is no possibility of collision in this test;
- c) Contact between VUT and VT occurs;

2.6.3.5 Test scenario end condition

Stop this scenario testing if VUT speed reduction <5 km/h or $V_{rel-impact}>50$ km/h.

2.6.3.6 Items to be noticed

For manual or automatic accelerator control, it is necessary to ensure that during automatic emergency braking of system, the accelerator pedal does not result in an override of automatic emergency braking action. The accelerator pedal is released when AEB system reduces the initial test vehicle speed by 5km/h. There should be no other driving control operation during the test, for example, control of clutch or brake pedal, etc.

2.6.3.7 Photographic and video record of test site

Before implementation of test, take photo for exterior of VUT in an overall manner, and take photo of VIN code of vehicle. Place video camera at an external position of vehicle, and take the video record of the entire test process. Ensure the definition of each video

to facilitate playback in the future. Video camera should be placed at appropriate height, and it is not allowed to adopt the suspension mode of arrangement. Video camera should be installed inside vehicle for further record of vehicle behavior.

2.7 Determination method of AEB system test validity

2.7.1 If manufacturer does not submit the predicated result, then only carry out one test at each test point.

2.7.2 If manufacturer submits the predicated result, then C-NCAP determines final result of test as per the predicated result and onsite test situation.

2.7.3 C-NCAP determines test results as per the following procedure:

2.7.3.1 Carry out the 1st test, if there is no difference ^a between the 1st test result and the predicated result, then take the test result as final test result, if there is difference ^b between the 1st test result and the predicated result, then perform the 2nd test;

Note:

a: there is no difference: the difference between test result and the predicated result and the speed difference between test results ≤5kph or the test result of misuse is identical with the predicated result.

b: There is difference: the difference between test result and the predicated result and the speed difference between test results >5kph or the test result of misuse is different from the predicated result.

2.7.3.2 Carry out the 2nd test, if there is no difference between the 2nd test result and the predicated result, then take the 2nd test result as final test result; if there is difference between the 2nd test result and the predicated result but there is no difference between the 1st test result and the 2nd test result, then take the average value of the 1st test result and the 2nd test result as final result; otherwise, perform the 3rd test;

2.7.3.3 Carry out the 3rd test, if there is no difference between results of two tests among three tests, then take the average value of the two test results as final result; if there is difference between results of all the three tests, then terminate test and restart test after analysis of root-cause.

2.7.3.4 The difference between final result of single test and the predicated result is taken as single time of invalidity, and stop use of the predicated results after accumulatively 5 times of invalidity, and only single test is performed in the future test.

2.7.4 See determination procedure of test validity as per Figure 77.

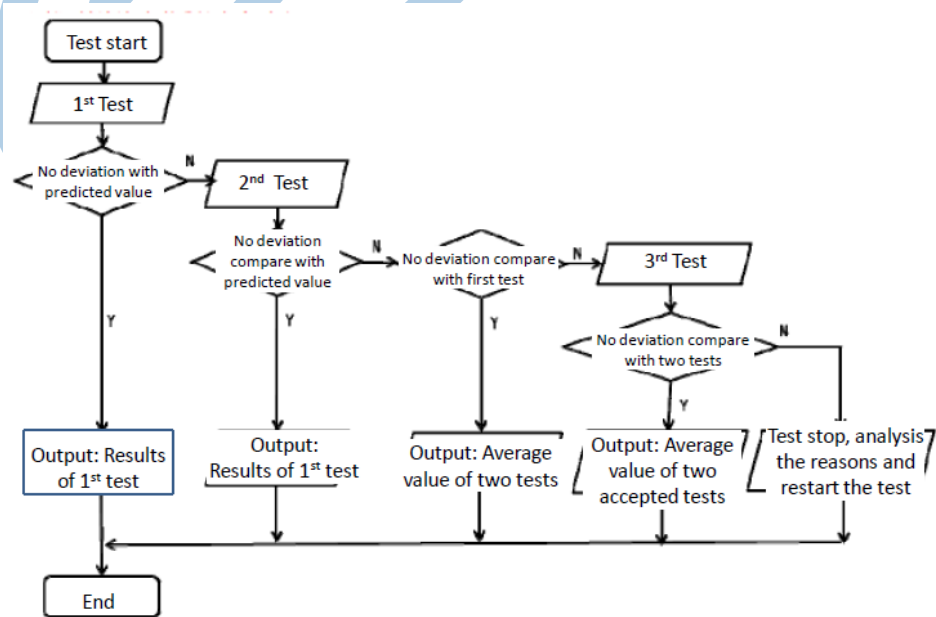

Figure 77 Determination procedure of test validity

2.8 Brake application procedure of FCW

The braking characteristic curve is used to determine the brake pedal displacement and pedal force necessary to achieve a vehicle deceleration (typical vehicle deceleration produced by a typical driver in response to regular emergency situations).

2.8.1 Definitions

T_{BRAKE} -- The moment when the brake pedal displacement reaches 5mm for the first time.

$T_{-6\text{m/s}^2}$ -- The moment when longitudinal acceleration is less than -6m/s^2 for the first time.

Definition of $T_{-2\text{m/s}^2}$ and $T_{-4\text{m/s}^2}$ is similar to $T_{-6\text{m/s}^2}$.

2.8.2 Brake characteristic curve calibration

First perform the brake running-in and tyre preconditioning as per 2.6.1.3 and 2.6.1.4 in this rule, and start calibration within 10min after end of preconditioning.

2.8.2.1 Calibration process

2.8.2.1.1 Push the brake pedal through the full extent of travel and release.

2.8.2.1.2 Accelerate the VUT to a speed above 85km/h. For vehicles with an automatic transmission, select gear D. For vehicles with a manual transmission, select the highest gear where the rotation speed is not less than 1,500RPM at 85km/h.

2.8.2.1.3 Release the accelerator pedal and allow the vehicle to coast. At a speed of (80 ± 1.0) km/h, apply brake with pedal application rate (20 ± 5) mm/s until the longitudinal acceleration of vehicle reaches -7m/s^2 . For manual transmission vehicles, depress the clutch when engine speed is below the 1,500RPM. The test ends when vehicle reaches -7m/s^2 .

2.8.2.1.4 Perform the test mentioned above for 3 times. A time interval between consecutive tests is 90s-10min. If the time interval exceeds 10min, brake running-in and the tyre preconditioning should be repeated before proceeding with calibration.

2.8.2.1.5 Use the results of three repeated tests mentioned above. Using second order curve fit and the least squares method in the scope of $T_{-2\text{m/s}^2}$ - $T_{-6\text{m/s}^2}$, calculate the pedal travel corresponding to $T_{-4\text{m/s}^2}$, the travel is D4.

2.8.2.1.6 Use the results of three repeated tests mentioned above. Using second order curve fit and the least squares method in the scope of $T_{-2\text{m/s}^2}$ - $T_{-6\text{m/s}^2}$, calculate the brake pedal force value corresponding to $T_{-4\text{m/s}^2}$, the brake pedal force is F4.

2.8.2.2 Confirmation of F4

2.8.2.2.1 Accelerate the VUT to a speed above 85km/h. For vehicles with an automatic transmission, select gear D. For vehicles with a manual transmission, select the highest gear where the rotation speed is not less than 1,500RPM at 85km/h.

2.8.2.2.2 Apply the braking force as per the step in 2.8.3, and calculate the average acceleration for $T_{\text{brake}+1\text{s}}$ - $T_{\text{brake}+3\text{s}}$, if the acceleration exceeds the scope of -4m/s^2 to -4.25m/s^2 , perform appropriate adjustment of braking force, if the braking acceleration meets the requirements of this scope for three consecutive tests, then the braking force is confirmed as the final F4. The determination test time interval is 90s-10min. If the time interval exceeds 10min, then brake running-in and the tyre preconditioning should be repeated.

2.8.3 Brake characteristic curve application method

2.8.3.1 During FCW test process, release the accelerator pedal at the moment of $T_{\text{FCW}+1\text{s}}$.

2.8.3.2 Activate the brake pedal at the moment of $T_{\text{FCW}+1.2\text{s}}$ with the lesser value of $5\times D4\text{mm/s}$ and 400mm/s.

- 2.8.3.3 During the above mentioned activation process, use second-order filter of (20-100) Hz for filtering and collection of pedal force.
- 2.8.3.4 When any of the following conditions are met first, switch to braking force control with a target of F_4 , the moment is referred to as T_{switch} .
- Travel of brake pedal reaches D_4 defined in 2.8.2.1.5.
 - Braking force of brake pedal reaches F_4 defined in 2.8.2.1.6.
- 2.8.3.5 Braking force should get stable the latest before $T_{switch}+0.2s$, and maintain in the scope of $(1\pm 25\%) \times F_4$. During the period, the braking force over the scope due to AEB interventions is allowed, as long as the duration time is less than 200ms.
- 2.8.3.6 The average value of the braking force in the entire process from $T_{FCW}+1.4s$ to the end of the test should be in the range of $F_4 \pm 10N$.

3 Pedestrian autonomous emergency braking system (AEB VRU_Ped) test

3.1 Vehicle coordinate system

“Vehicle coordinate system” of AEB VRU_Ped system test makes reference to 2.1 of this chapter.

3.2 Lateral offset

The lateral offset refers to the horizontal distance between the center of the front of vehicle and the planned route. Figure 78 is a schematic diagram of lateral offset of VUT.

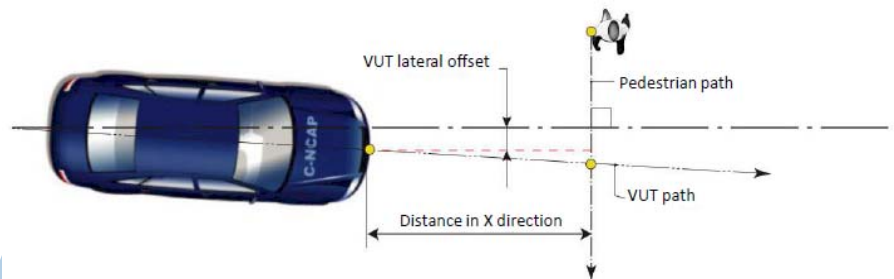

Figure 78 Lateral offset

3.3 Impact position determination

A virtual profiled line is defined around the front end of the VUT. The virtual profiled line is defined by straight line connecting seven points that are equally distributed over the residual width after minus of 50mm from vehicle width on each side. As shown in Figure 79.

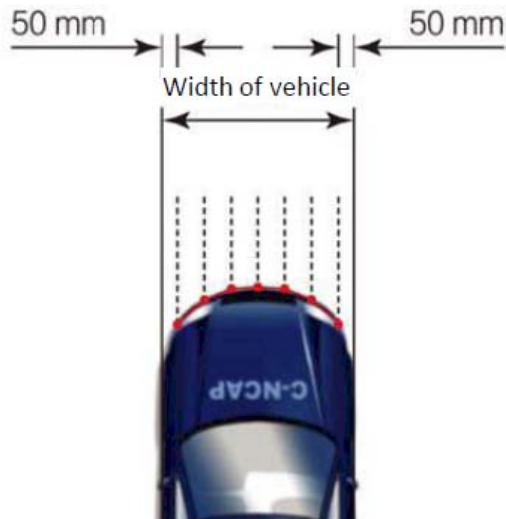

Figure 79 Virtual profiled line around VUT front end

Manufacturer should submit VUT virtual profiled line information (values A, B and C) and C-NCAP laboratory should confirm, as shown in Figure 80.

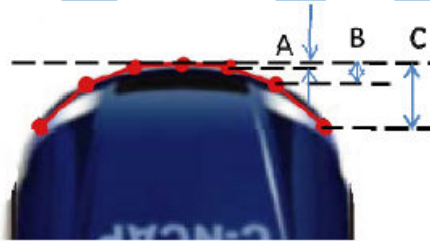

Figure 80 Diagram of virtual border position

Around PTA, a virtual rectangle box is defined, height of H-point in the Figure is (923 ± 20) mm, as shown in Figure 81. When the virtual profiled line of VUT gets in contact with the virtual box of PTA, it is determined that impact occurs, as shown in Figure 82.

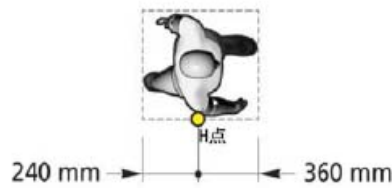

Figure 81 Dimensions of virtual box of PTA



Figure 82 Determination of impact between PTA and VUT

3.4 Test equipment and target dummy

3.4.1 Test equipment

3.4.1.1 Test equipment should satisfy sample and storage of dynamic data, frequency of sample and storage should be at least 100Hz. Synchronize data between PTA and VUT by using DGPS time.

3.4.1.2 The accuracy of data acquisition and record equipment should at least meet the following requirements during test process of VUT and PTA:

- a) VUT speed accuracy of 0.1km/h;
- b) PTA speed accuracy of 0.01km/h;
- c) VUT lateral and longitudinal position accuracy of 0.03m;
- d) PTA lateral position accuracy of 0.03m;
- e) VUT yaw rate accuracy of 0.1°/s;
- f) VUT longitudinal acceleration accuracy of 0.1m/s²;
- g) VUT steering wheel velocity of 1.0°/s.

3.4.2 Data filtering

3.4.2.1 Position and speed adopt original data and are not filtered.

3.4.2.2 Acceleration is filtered with a 12-pole phaseless Butterworth filter with a cut off frequency of 10Hz;

3.4.2.3 Yaw rate is filtered with a 12-pole phaseless Butterworth filter with a cut off frequency of 10Hz;

3.4.3 Target dummy

3.4.3.1 PTA is used to replace pedestrian (including visual, radar, LIDAR and PMD attributes).

3.4.3.2 See the specific requirements on PTA as per “Euro-NCAP TEST PROTOCOL-AEB VRU systems Version 1.0.1 June 2015 ANNEX A EPT SPECIFICATIONS”.

3.4.3.3 Manufacturer may select pedestrian target with fixed leg or pedestrian target with articulate leg. Figure 83 is schematic diagram of pedestrian target with fixed leg.



Figure 83 C-NCAPPTA appearance diagram

When a manufacturer believes that PTA cannot meet the requirements of VUT sensor for target, the manufacturer is asked to contact the C-NCAP Administration Center directly.

3.5 Test conditions

3.5.1 Test site requirement

3.5.1.1 Test road surface is required to be dry, free from visible moisture, flat and solid, with a consistent gradient between level and 1%, and the peak breaking coefficient should be more than 0.9;

3.5.1.2 Within 6m from center line of test route for driver side and 4m for occupant side, there should be no other vehicle, highway facilities, obstacle, human or other projection that may give rise to abnormal sensor operation within test zone of 30m ahead of test end point; as shown in Figure 84.

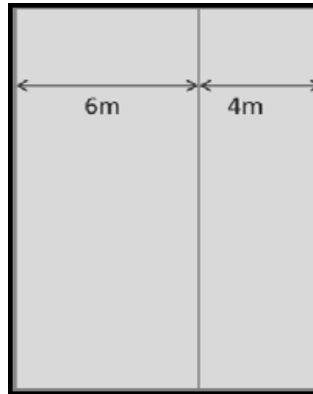

Figure 84 Scope of test zone

3.5.1.3 The presence of lane markings is allowed on test road, however, lane marking lines should not cross the test path in the area where AEB activation and braking after FCW is expected.

3.5.2 Requirements on test weather

“Requirements on test weather” of AEB VRU_Ped test makes reference to 2.4.2 in this chapter.

3.6 VUT preparation work

“VUT preparation work” of AEB VRU_Ped test makes reference to 2.5 in this chapter.

3.7 Test process

3.7.1 VUT test preconditioning

“VUT test preconditioning” of AEB VRU_Ped test makes reference to 2.6.1 in this chapter.

3.7.2 Test scenarios

3.7.2.1 AEB VRU_Ped system performance test scenario

3.7.2.1.1 AEB VRU_Ped system has four test scenarios of CVFA-25, CVFA-50, CVNA-25 and CVNA-75, see Figure 85a) and Figure 85b), pedestrian route is perpendicular to vehicle route.

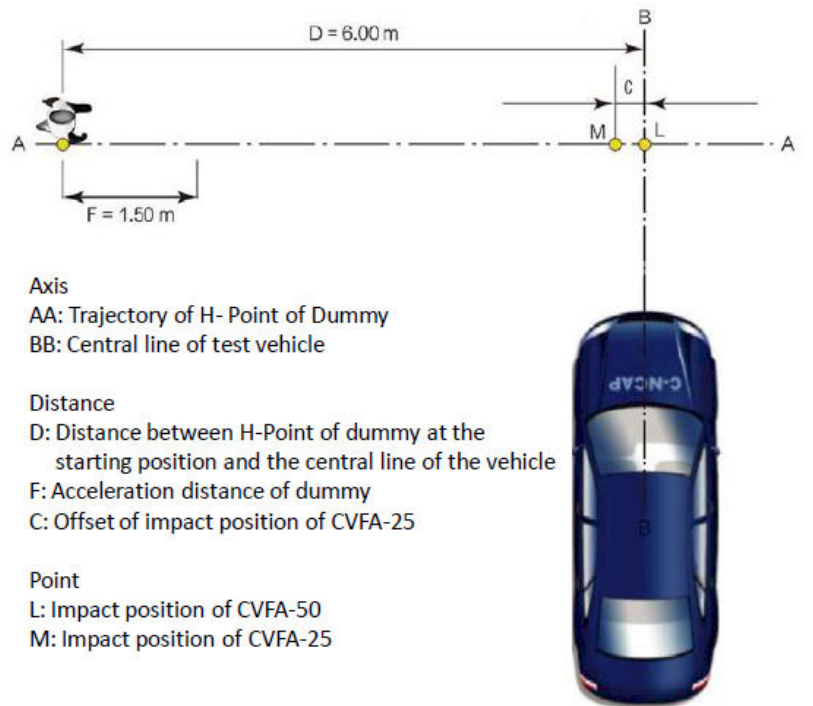

Figure 85a) Schematic diagram of farside scenario (CVFA-25 and CVFA-50)

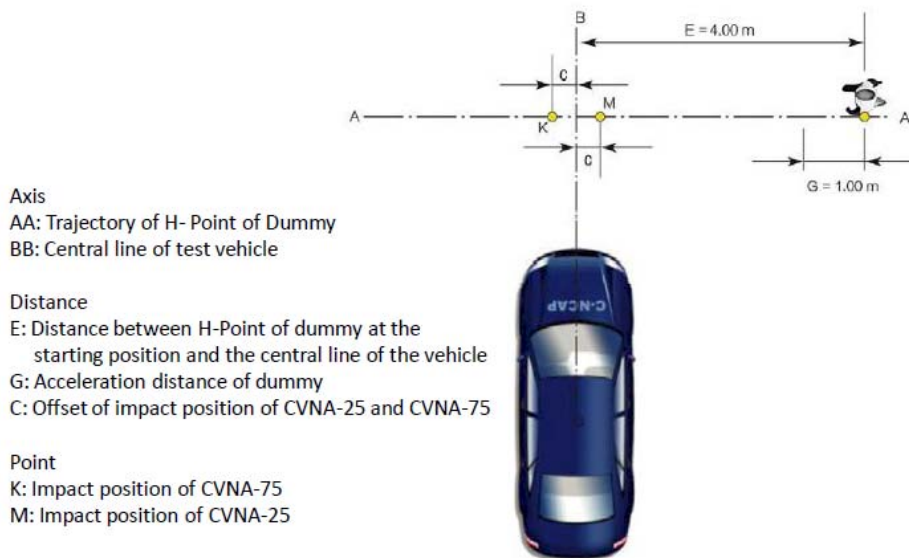

Figure 85b) Schematic diagram of nearside scenario (CVNA-25 and CVNA-75)

- 3.7.2.1.2 In farside scenario, pedestrian moves at speed of 6.5km/h along direction perpendicular to vehicle running direction. VUT is tested respectively at speeds of 20km/h, 30km/h, 40km/h, 50km/h and 60km/h. Collision positions of 25% and 50% correspond to points "M" and "L" in 85a).
- 3.7.2.1.3 In nearside scenario, pedestrian travels at speed of 5km/h along direction perpendicular to vehicle running direction. VUT is tested respectively at speeds of 20km/h, 30km/h, 40km/h, 50km/h and 60km/h. Collision positions of 25% and 75% correspond to points "M" and "K" in Figure 85b).

3.7.2.2 Summary of AEB VRU_Ped test scenarios

Table 37 AEB VRU_Ped system test scenarios

Test scenarios	Pedestrian speed	Vehicle speed
CVFA-25	6.5km/h	20km/h-60km/h (10km/h interval)
CVFA-50	6.5km/h	
CVNA-25	5km/h	
CVNA-75	5km/h	

For the CVNA-75 scenario, the following tests are added too:

- Test vehicle speed of 20km/h with PTA speed of 3km/h;
- Test vehicle speed of 10km/h and 15km/h with PTA speed of 5km/h;
- When test vehicle speed is 45km/h, PTA speed is 5km/h.

3.7.3 Test requirements

3.7.3.1 Gear selection and vehicle control

For vehicles with an automatic transmission, select gear D. For vehicles with a manual transmission, engage the highest gear of transmission where engine speed reaches at least 1,500RPM at the test speed. A speed limiting device or cruise device on VUT may be used to maintain the test vehicle speed, unless the vehicle manufacturer indicates that these functions influence the AEB system work. It is allowed to turn steering wheel slightly to keep VUT to run along the planned route if necessary.

3.7.3.2 Time interval

Start the first test within 90s-10min after completing the tyre preparation, and the time interval between end of each test and start of the subsequent test is also 90s-10min. If the time interval exceeds 10min, it is necessary to perform tyre preparation again. In the test interval, unless special circumstance seriously influences vehicle safety, speed of VUT should not exceed 50km/h, and harsh acceleration, deceleration or steering operation should be avoided.

3.7.3.3 Test accuracy

Accelerate VUT and VT (if necessary) to the required test vehicle speed. VUT should meet the following conditions within time scope between T_0 and T_{AEB}/T_{FCW} :

- Speed of VUT (GPS speed): test speed + 0.5 km/h;
- Lateral deviation of VUT: $0 \pm 0.05m$;
- Yaw velocity: $0 \pm 1.0^\circ/s$;
- Steering wheel turning velocity: $0 \pm 15.0^\circ/s$;

Meanwhile, from the moment when PTA is 3m (nearside scenario)/4.5m (farside scenario) from vehicle centerline to impact moment; pedestrian speed should meet the following requirements:

- Speed of PTA during CVFA: $6.5 \pm 0.2km/h$;
- Speed of PTA during CVNA: $5 \pm 0.2km/h$.

3.7.3.4 Conditions for end of single test

Test ends when one of the following conditions occurs:

- $V_{VUT} = 0km/h$;
- Contact between VUT and PTA occurs;
- PTA has left the VUT running path.

3.7.3.5 Test scenario end condition

Stop testing when vehicle speed reduction is $<20\text{km/h}$ in the tests of $V_{VUT}>40\text{km/h}$ or when the manufacturer predicts no performance.

3.7.3.6 Items to be noticed

For manual or automatic accelerator control, it is necessary to ensure that during automatic emergency brake, the accelerator pedal does not result in an override of brake action. The accelerator pedal needs to be released when the initial vehicle speed is reduced by 5km/h due to autonomous emergency brake. There should be no other driving control operation during the test, for example, clutch or brake pedal.

3.7.3.7 Photographic and video record of test site

“Photographic and video record of test site” makes reference to 2.6.3.7 of this Chapter.

3.8 AEB VRU_Ped system test validity determination method

“AEB VRU_Ped system test validity determination method” makes reference to 2.7 of this Chapter.

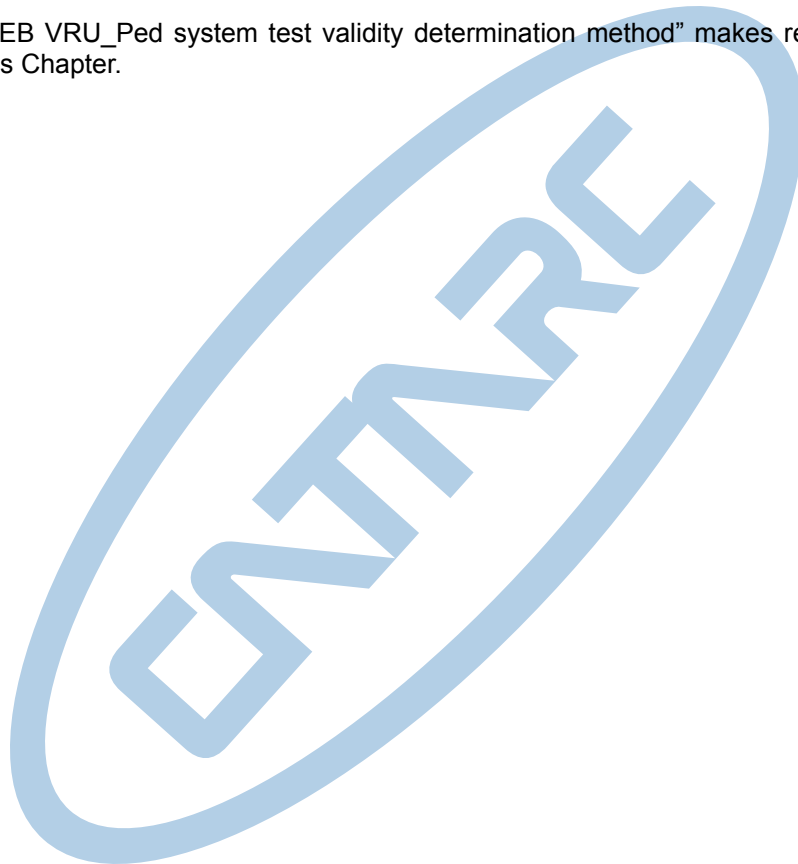

Chapter VII Additional Test -- Fuel Consumption Measurement Procedures

1 Inspections of vehicle

- 1.1 Fill out the vehicle check list (see Table 38);
- 1.2 If applicable, check the OBD information;
- 1.3 If necessary, confirm the kerb mass of the vehicle.

2 Test preparations

2.1 Affixing C-NCAP logo and vehicle markings

Each test vehicle shall be affixed with the C-NCAP logo and the sole vehicle marking – test serial number.

2.2 Replacement of fuel

2.2.1 Check of fuel

The lab test fuel shall be used; prior to the measurements of fuel consumption, check and record the density and temperature of the test fuel.

2.2.2 Replacement of fuel

- (1) Empty the fuel tank;
- (2) Refill in the lab test fuel up to 40% of the nominal tank volume (with fuel temperature less than 30°C);
- (3) Cap the fuel tank lid.

2.3 Pre-conditioning

2.3.1 Ambient conditions

Room temperature: 24°C±3°C; humidity: (5.5~12.2) g of water/kg of air.

2.3.2 Warm-up of chassis dynamometer

Provided that the measurement of the preceding vehicle has ended for more than 50 min, it is necessary to warm up the chassis dynamometer (at the constant speed of 80 km/h for 30 min).

2.3.3 Check of vehicle

- (1) Secure the test vehicle, and adjust the tire inflation pressure to the value indicated by the manufacturer;

Note: The vehicle shall be secured onto the chassis dynamometer as horizontally as possible, so as to minimize any extra force applied onto the surface of wheels and drum except for the gravity.

- (2) Where necessary, confirm the position of overdrive switch;
- (3) Check that all the on-board accessories have been shut off (air-conditioner, fan, ABS, TRC, radio, etc.);
- (4) Check the drive mode (all-wheel-drive/two-wheel-drive mode);
- (5) Mount the cooling fan in front of the vehicle, 0.3m apart;
- (6) Connect the CVS sampling tube with the tail pipe of the vehicle.

Table 38 Vehicle check list (Upon receiving/returning the vehicle)

VIN		Engine model	Upon receiving		Upon returning	
Transmission	AT/MT	Tyre model	Inspected	(/) by:	Inspected	(/) by:
No.	Items	Keypoints	Result	Remarks	Result	Remarks
1	Odometer	Write down odometer reading	Y <input type="checkbox"/>		Y <input type="checkbox"/>	
2	Battery	Check if connections remaining good conditions	Y <input type="checkbox"/>		Y <input type="checkbox"/>	
3	Radiator	Check if coolant remaining good conditions	Y <input type="checkbox"/>		Y <input type="checkbox"/>	
4	Engine oil	Engine	Y <input type="checkbox"/>		Y <input type="checkbox"/>	
		Clutch/AT	Y <input type="checkbox"/>		Y <input type="checkbox"/>	
		Brake/P/S	Y <input type="checkbox"/>		Y <input type="checkbox"/>	
5	Exhaust pipe	Start up the engine, to check if any noticeable leakage exists with the exhaust system	Y <input type="checkbox"/>		Y <input type="checkbox"/>	
6	Harness, and engine compartment pipelines	Rupture, disturbance (visual inspection)	Y <input type="checkbox"/>		Y <input type="checkbox"/>	
7	Safety belt	Tension, wearing, damage	Y <input type="checkbox"/>		Y <input type="checkbox"/>	
8	Fuel system	Leakage	Y <input type="checkbox"/>		Y <input type="checkbox"/>	
9	Tyre and wheel	Size, wearing degree	Y <input type="checkbox"/>		Y <input type="checkbox"/>	
10	Idling	Abnormal sound/vibration, start-up performance, engine speed	Y <input type="checkbox"/>		Y <input type="checkbox"/>	
11	Safety operation at gear 'N'	Engine doesn't start up unless at the gear 'P/N'	Y <input type="checkbox"/>		Y <input type="checkbox"/>	
12	Instruments	Working status, warning indicators /MIL (check diagnostic codes, if necessary)	Y <input type="checkbox"/>		Y <input type="checkbox"/>	
13	Clutch, brake	Check pedal actions	Y <input type="checkbox"/>		Y <input type="checkbox"/>	
14	Towing hook for a frontal-wheel-drive vehicle	Place it in the compartment	Y <input type="checkbox"/>		Y <input type="checkbox"/>	
		Remove and place it into the compartment	N <input type="checkbox"/>		N <input type="checkbox"/>	
15	Wrap of driving wheel	Remove and place it into the compartment	Y <input type="checkbox"/>		Y <input type="checkbox"/>	
		If 2-wheel-drive mode is used for the test, furnish the effective switching program (2WD <--> 4WD)	N <input type="checkbox"/>		N <input type="checkbox"/>	
16	4-wheel-drive vehicle	Cut off the drive axle, and place it into the compartment	Y <input type="checkbox"/>		Y <input type="checkbox"/>	
17	Outer surface of bodywork	Scratch, dirt	Y <input type="checkbox"/>		Y <input type="checkbox"/>	
18	On-board accessories	Except for necessary ones, any articles shall be taken out of the compartment	Y <input type="checkbox"/>		Y <input type="checkbox"/>	
19	ECU	Harness remains in good connections	Y <input type="checkbox"/>		Y <input type="checkbox"/>	
20	Indication of fuel gauge	Check the remaining fuel quantity in fuel tank	Y <input type="checkbox"/>		Y <input type="checkbox"/>	

2.3.4 Setting of resistance

With the console of the chassis select and confirm the equivalent inertia weight and load used for the in accordance with Table 39.

dynamometer, measurements

Table 39 Power and load absorbed by dynamometer

Reference mass (RM) of vehicle kg	Equivalent inertia weight KG	Power and load absorbed by dynamometer at 80km/h		Coefficients	
		kW	N	a	b
RM ≤ 480 <	455	3.8	171	3.8	0.0261
480 < RM ≤ 540	510	4.1	185	4.2	0.0282
540 < RM ≤ 595	570	4.3	194	4.4	0.0296
595 < RM ≤ 650	625	4.5	203	4.6	0.0309
650 < RM ≤ 710	680	4.7	212	4.8	0.0323
710 < RM ≤ 765	740	4.9	221	5.0	0.0337
765 < RM ≤ 850	800	5.1	230	5.2	0.0351
850 < RM ≤ 965	910	5.6	252	5.7	0.0385
965 < RM ≤ 1080	1020	6.0	270	6.1	0.0412
1080 < RM ≤ 1190	1130	6.3	284	6.4	0.0433
1190 < RM ≤ 1305	1250	6.7	302	6.8	0.0460
1305 < RM ≤ 1420	1360	7.0	315	7.1	0.0481
1420 < RM ≤ 1530	1470	7.3	329	7.4	0.0502
1530 < RM ≤ 1640	1590	7.5	338	7.6	0.0515
1640 < RM ≤ 1760	1700	7.8	351	7.9	0.0536
1760 < RM ≤ 1870	1810	8.1	365	8.2	0.0557
1870 < RM ≤ 1980	1930	8.4	378	8.5	0.0577
1980 < RM ≤ 2100	2040	8.6	387	8.7	0.0591
2100 < RM ≤ 2210	2150	8.8	396	8.9	0.0605
2210 < RM ≤ 2380	2270	9.0	405	9.1	0.0619
2380 < RM ≤ 2610	2270	9.4	423	9.5	0.0646
2610 < RM	2270	9.8	441	9.9	0.0674

Notes:
 ① RM = kerb mass + 100kg (the kerb mass is cited from the design parameters as provided by manufacturer);
 ② Except for vehicles of Category M1, the power values presented in the table above shall be multiplied by a coefficient 1.3 for any vehicle with the R M > 1,700kg or for a full-time four-wheel-drive vehicle.

2.3.5 Pre-conditioning

- (1) Turn on the cooling fan;
- (2) Gasoline vehicles shall be preconditioned over the cycle shown in Figure 86;

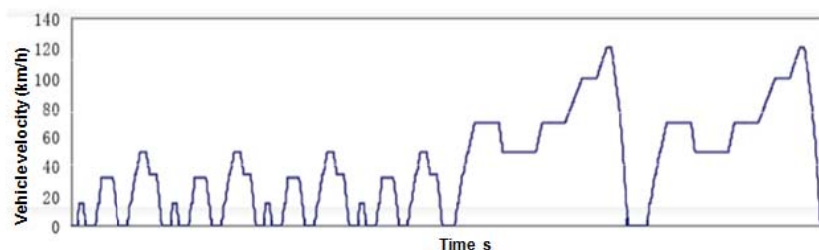

Figure 86 Cycle curve for preconditioning of a gasoline vehicle

- (3) A diesel vehicle shall be preconditioned over the cycle shown in Figure 87.

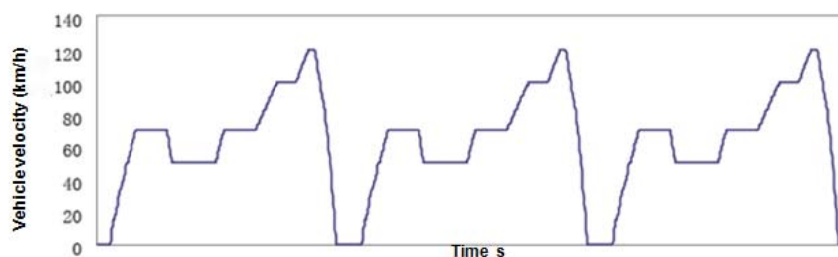

Figure 87 Cycle curve for preconditioning of a diesel vehicle

2.3.6 Soaking

- (1) At the end of the pre-conditioning, it is forbidden to re-start up the engine;
- (2) In case any vehicle relocation is necessary after the engine off, manual efforts are needed to push the vehicle;
- (3) The soaking duration shall be 18~24h. After the start of soaking, record the initial time, the odometer reading, and the temperature of the soaking zone.

3 Test

3.1 Warm-up of equipment

- (1) Provided that the measurement of the preceding vehicle has ended for more than 50min, it is necessary to warm up the chassis dynamometer (at the constant speed of 80km/h for 30min);
- (2) Prior to the test, analyzers shall be warmed up for at least 1h, and the HC and NOX analysis unit shall put into normal operation (with gas circulated therein) for at least 30min.

3.2 Inspection of vehicle

- (1) Confirm that the soaking duration falls within 18~24h;
- (2) Check and record the room temperature, engine oil temperature, and engine coolant temperature; both engine oil temperature and engine coolant temperature must fall within $\pm 2^{\circ}\text{C}$ of the soaking chamber temperature; otherwise, continue the soaking until the above requirements are met.

3.3 Vehicle preparations

- (1) Secure the test vehicle, check and adjust the tire inflation pressure to the prescribed value;
Note: The vehicle shall be secured onto the chassis dynamometer as horizontally as possible, so as to minimize any extra force applied onto the surface of wheels and drum except for the gravity.
- (2) Where necessary, confirm the position of overdrive switch;
- (3) Check that all the on-board accessories have been shut off (air-conditioner, fan, ABS, TRC, radio, etc.);
- (4) Check the drive mode (all-wheel-drive/two-wheel-drive mode);
- (5) In case of automated transmission, check that the gear-shift lever rests at the "P (parking)" position;
- (6) Confirm the engine hood has been closed.

3.4 Preparation of equipment

- (1) Confirm that the room temperature falls within $24^{\circ}\text{C} \pm 3^{\circ}\text{C}$ and the absolute humidity within $5.5\text{g/kg} \sim 12.2\text{g/kg}$;
- (2) Check the setting of equivalent inertia weight and load on the chassis dynamometer;
- (3) Confirm the volume of CVS;
- (4) Mount the cooling fan in front of the vehicle, 0.3m apart;
- (5) Connect the CVS sampling tube with the tail pipe of the vehicle;
- (6) Confirm both zero and range gases are normal, with the precision not less than 2%.

3.5

Test

- (1) The test cycle is shown in Figure 88;

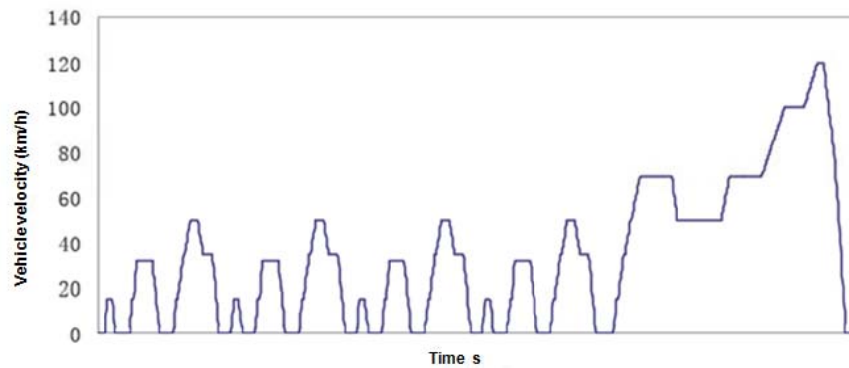

Figure 88 Test cycle

- (2) Lasting for 1,180 s in total, the test, comprising two parts (urban cycle and suburban cycle), shall be uninterruptedly conducted until its end;
- (3) Upon ignition of the engine, it is forbidden to press down the acceleration pedal;
- (4) The driver shall control the acceleration and brake pedals as stably as possible, so as to maintain the travel to follow the curve tolerance;
- (5) In case an overdrive gear (to be manipulated by the driver) is fitted, it may be used for the suburban cycle (i.e., forbidden to use for the urban cycle);
- (6) In case of automated transmission, the gear shall be shifted to 'D' upon 6 s after the ignition of the engine; afterwards, no gear-shifting operation is allowed throughout the test, except for particular cases;
- (7) In case of a manual transmission comprising more than 5 gear ratios, the user's manual or the manufacturer's suggestions may be consulted;
- (8) In case of combined transmission, the procedures for automated transmission shall apply;
- (9) During the test, diluted mode data may be gathered;
- (10) The analysis of the sampling bags shall be completed within 20 min after the engine off;
- (11) Check whether the MI (malfunction indicator) goes off and whether the OBD system presents any fault code.

3.6

Data processing

Data shall be processed with reference to the provisions of GB/T19233-2008.

4

Vehicle parameters to be verified for the additional test

4.1

Basic information of vehicle necessary for the test

- ① Any particular requirement for transmission manipulation during test
- ② Requirements for using the overdrive switch of automatic transmission
- ③ Elimination of speed limit arising from ABS warning, e.g., on-off of TRC
- ④ Drive type and tyre inflation pressure of driven wheels
- ⑤ Other matters to be explained

4.2

Parameters necessary for issuing the test report

See Appendix 9.



Appendix 1 Feedback Sheet for Vehicles Undergoing C-NCAP Assessment

Vehicle manufacturer						
Vehicle type				Total sales volume		
Series put for sales				Configuration as the sample vehicle / sales volume of this type		
Trademark						
Time to market of the latest remoulded type						
Basic parameters and configuration of vehicle	Overall dimension	L×W×H (mm)				
	Mass	Complete vehicle gross mass (kg)				
		Complete vehicle kerb mass (kg)				
	Bodywork type					
	Engine	Model				
		Manufacturer				
		Displacement/power (ml/kW)				
		Number of cylinders				
		Fuel type				
	Transmission	Auto or manual				
		Number of gears and gear ratios				
	Drive type	Front-wheel/rear-wheel/all-wheel drive				
	Restraint system	Safety belt (mounting position, number)				
		Verify whether the second row is to be equipped with safety belts or not		Yes <input type="checkbox"/>	No <input type="checkbox"/>	
		Quantity and position of ISOFIX				
		Safety belt reminder (position, number)		First row:		
				Second row:		
		Frontal airbag (mounting position, number)				
		Side airbag (air curtain) (mounting position, number)				
	Driver's seat	Seat model				
		Manufacturer				
		Equipped with active headrest or not		Yes <input type="checkbox"/>	No <input type="checkbox"/>	
	Others	Color distribution of predicated results of pedestrian protection head form		(Description material attached separately)		
Application for addition of pedestrian protection test program		(Description material attached separately)				
Active engine cover						
ESC system						
AEB system						
Production information	Is it to discontinue production within one year?	Yes <input type="checkbox"/>	No <input type="checkbox"/>	If yes, when?		
	Is there a production of the new generation?	Yes <input type="checkbox"/>	No <input type="checkbox"/>	If yes, when is it to be put in the market?		
Modification plan	Which type of modification?	Body <input type="checkbox"/> Construction <input type="checkbox"/> Safety configuration <input type="checkbox"/> Others <input type="checkbox"/>				
	If there is a plan of modification?	Yes <input type="checkbox"/>	No <input type="checkbox"/>	If yes, when is it to be put in the market?		
How long will the pedestrian protection	The parts will not be	within 1 month <input type="checkbox"/>	within 1-2 month <input type="checkbox"/>	within 3 month <input type="checkbox"/>		

parts be provided?	provided <input type="checkbox"/>		
Information about franchised stores	Give information concerning franchised stores in Beijing, Tianjin or other regions: (An additional sheet may be used if the space is not enough) Where no vehicle of such type is available in franchised stores, is the selection of sample vehicles from production line permitted? Yes <input type="checkbox"/> No <input type="checkbox"/>		
Communication	Contact person		Tel./cell phone
	Zip code		Fax.
	Address		
other comments			
Authorized representative's signature or common seal	(d/m/y)		
<p>Note: The information presented above shall apply to the vehicle type with the configuration attaining the largest sales volume; pertaining proofing documents shall be furnished altogether. Where the manufacturer wishes to have other vehicle type(s) assessed, which has reached certain sales volume, any information as described above may also be given and such vehicle type(s) is to be listed as candidate vehicle type(s).</p>			



Appendix 2 C-NCAP Test Performing Notice

Vehicle manufacturer			
Vehicle number and VIN number			
Configuration			
Test items and date	Fuel consumption measurement	(d/m/y)~(d/m/y)	
	AEB test	(d/m/y)~(d/m/y)	
	Pedestrian protection	(d/m/y)~(d/m/y)	
	Full frontal impact	(d/m/y)	
	Offset frontal impact	(d/m/y)	
	Side impact	(d/m/y)	
	Whiplash test	(d/m/y)	
Matters needing attention			
Contact person	Telephone	Fax.	
Common seal	(d/m/y)		

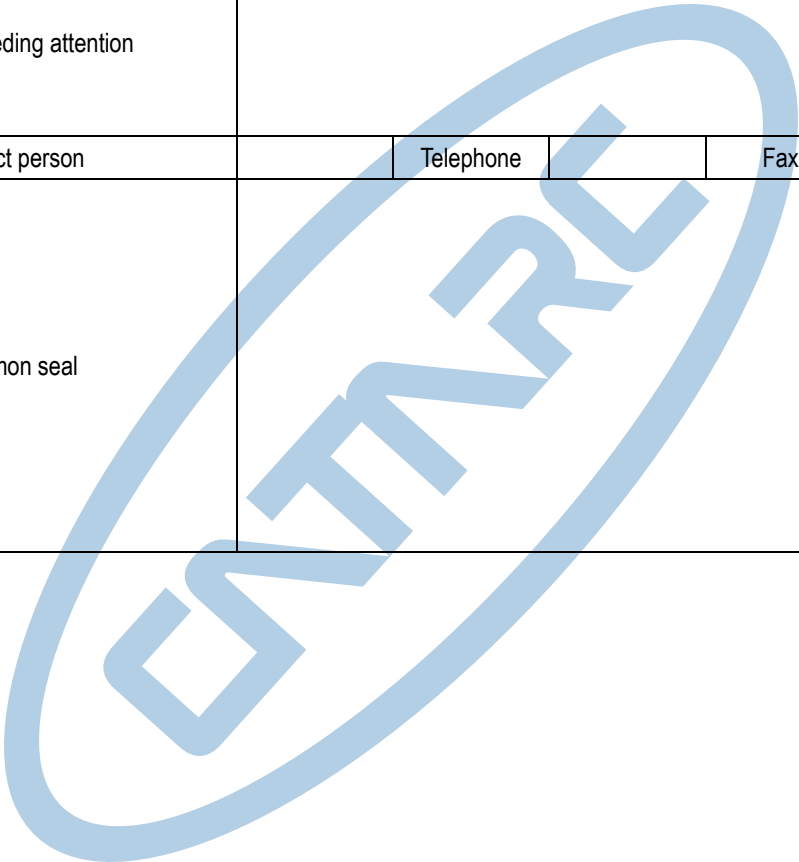

Appendix 3-1 C-NCAP Basic Parameters of the Test Vehicle 1 - (Part of Crash and Whiplash Tests)

Completed on: (d/m/y)

Trademark, name and model of vehicle		Vehicle type			
Manufacturer					
Vehicle identification number (VIN) Engine number					
Date of manufacture					
Complete vehicle kerb mass and axle load (kg)					
Complete vehicle gross mass and axle load (kg)					
Engine model and manufacturer					
Engine arrangement mode		Front (horizontal, longitudinal), middle, rear			
Half-laden tyre pressure (kPa)					
Tyre model and manufacture					
Rated voltage of battery (V)		Engine displacement (ml)			
Transmission model		Transmission arrangement mode			
Rated capacity of fuel tank		Fuel type			
Vehicle L×W×H (mm)		Number of doors			
Number of seats in complete vehicle		Number of seats in the front row			
Model and type of steering column		Model: Adjustable (yes/no) Crushable (yes/no)			
Steering wheel	Design position or middle position in forward and backward directions				
	Design position or middle position in upper and lower directions				
Safety belt and anchorage		Model and manufacturer	Pretensioner	Force limiter	Design position of upper anchorage
Safety belt	Driver		Yes/No	Yes/No	
	Front occupant		Yes/No	Yes/No	
	Left rear occupant		Yes/No	Yes/No	
	Middle rear occupant		Yes/No	Yes/No	
	Right rear occupant		Yes/No	Yes/No	
Safety belt reminder		Fitted or not	Mounting position		Visual or audible
		Yes <input type="checkbox"/> No <input type="checkbox"/>	Front: Driver <input type="checkbox"/>		Visual <input type="checkbox"/> Audible <input type="checkbox"/>
			Occupant <input type="checkbox"/>		Visual <input type="checkbox"/> Audible <input type="checkbox"/> Monitor system: Yes <input type="checkbox"/> No <input type="checkbox"/>
Model and manufacturer of front-occupant frontal airbag		Driver			
		Occupant			
		Other position			
Model and manufacturer of side airbag (either side)		Front			
		Rear			
		Other position			
Seat design parameters		Design R-point coordinate	Longitudinal adjustable design position	Vertical adjustable design position	Backrest angle adjustable design position
Front seat	Driver				
	Occupant				
Rear seat					
Seat parameters for frontal impact		H-point coordinate of seat at test position	Longitudinal adjustable position	Vertical adjustable position	Backrest angle adjustable position
Front seat	Driver		Middle		
	Occupant		Middle		
Rear seat					
Seat parameters for side impact		H-point coordinate of seat at test position	Longitudinal adjustable position	Vertical adjustable position	Backrest angle adjustable position

Front seat	Driver		Middle					
To furnish the coordinates of 8 characteristic points within the vehicle body design coordinate system; also, it shall assure that these 8 points will not undergo any deformation after the test.								
1	2	3	4	5	6	7	8	
Whether doors could be locked up automatically	Yes <input type="checkbox"/> No <input type="checkbox"/>							
If yes, whether the lock-up could be eliminated automatically	Yes <input type="checkbox"/> No <input type="checkbox"/>							
Fitted with child restraint system anchorage or not (ISOFIX)	Yes <input type="checkbox"/> No <input type="checkbox"/>	ISOFIX number		ISOFIX position				
	Type, manufacturer and model of CRS applicable to this vehicle type							
Model and manufacturer of for driver's seat								
Seat design parameters	Design H-point coordinate	Track travel	Longitudinal adjustable design position	Vertical adjustable design position	Backrest angle design position			
Installation parameters for driver's seat	Coordinates of seat set-bolt hole					Seat track inclination		
			Front left	Front right	Rear left			Rear right
		X						
	Coordinates	Y						
		Z						
	Intersection angle between normal direction and coordinate axis	Axis-X						
		Axis-Y						
		Axis-Z						
		Seat fixed bolt specification (thread, pitch, etc.)						
		Seat fixing bolt tightening torque						
	Sagittal plane Y value in the seat							
Driver's seat parameters of whiplash test	H-point coordinates of seat at test position	Height of head restraint adjustable?	Head restraint longitudinally adjustable?	Type of head restraint		Triggering moment		
				<input type="checkbox"/> Non-proactive head restraint		--		
				<input type="checkbox"/> Retraction type pro-active head restraint		--		
				<input type="checkbox"/> Triggering type pro-active head restraint				
Height of heel rest point								

Appendix 3-2 C-NCAP Basic Parameters of the Test Vehicle 2 -(Part of Pedestrian Protection)

Completed on:(d/m/y)

1. Basic parameters of pedestrian protection

Basic parameters table of pedestrian protection	
Items	Sample status
Name, number and brand of the Vehicle	
Vehicle type	
Vehicle manufacturer	
Complete vehicle curb mass (kg)	
Front axle load(kg)	
Tear pressure(kpa)	
Tank nominal volume(L)	
Designed body height at normal driving condition (such as wheel arc height)	
Parameters of suspension(if active suspension or not)	
Suspension height under normal driving	
Vehicle coordinate(at least 3 observable referent points under engine cover)	X: Y: Z: X: Y: Z: X: Y: Z: (More information can be attached.)
Coordinates of net points in head form test zone	(X: Y: Z: saved as attachment)
Prediction of test results picture in color	Prediction of test results picture in color(saved as attachment)

2. Test parts list of pedestrian protection

Test parts list of pedestrian protection			
No.	Part name	Quantity	Comments
1	Vehicle	1	
2	Engine cover	10	With standard installation components
3	Engine hinge(left)	3	With standard installation components
4	Engine hinge(right)	3	With standard installation components
5	Engine cover lock	2	With standard installation components
6	Engine cover blimp and foam	3	With standard installation components(10)
7	Windscreen wiper assembly	3	With standard installation components
8	Wiper groove cover assembly	3	With standard installation components
9	Bumper assembly	4	With bumper trim, foam und installation components
10	Wheel fender(left)	2	With standard installation components
11	Wheel fender(right)	2	With standard installation components
12	Car grills assembly	4	With standard installation components
13	Headlamp assembly(left)	2	With standard installation components
14	Headlamp assembly(right)	2	With standard installation components
15	Front windshield glazing	3	
16	Active deployable bonnet system accessories	12	With standard installation components
17	Guide book of installation of vehicle frontal structure	1	

Note: OEMs should offer additional relevant test samples, if the OEMs apply for additional tests or there are blue net points in the head form test area.

3. Information regarding active deployable bonnet system test

3.1. Preparation for the tests

No.	Items	Details of system function				Submitted Documents	Comments
		Test	Impact instrument	Impact position	Speed		
1	Detection of pedestrians	1	PD12 or HTD	1. Sensor arrangement position $\pm 50\text{mm}$ (for example, acceleration sensor). If the sensing system uses a combination of contact strip switch and acceleration sensor, the position of the impact acceleration sensor. 2. Vehicle center position: non-localized sensing systems (such as contact switches).	LT $\pm 2\text{km/h}$	The output should include: 1. High speed film; 2. Trigger time; 3. Initiation time of deployment.	C-NCAP Test Assessment Department should witness the tests or carry out the test 3.
		2	PD12 or HTD	Leg form test zone left or right side. Impact position deviation $\pm 50\text{mm}$.	LT $\pm 2\text{km/h}$		
		3	PD12 or HTD	Farthest position from sensor (perform if not tested already at the position).	LT $\pm 2\text{km/h}$		
		4*	FLEX or TRL lower leg	Sensor arrangement position $\pm 50\text{mm}$ (for example acceleration sensor) or position where it is easy to generate large acceleration for impactor (non-localized sensing systems).	40km/h $\pm 2\text{km/h}$		
		5	PD12 or HTD	Sensor arrangement position or vehicle center position	50km/h		
2	Initiation time of deployment	Response time of the active bonnet system (TRT), sensing time of the active bonnet system (ST) and deployment time of the active bonnet system (DT)				Result of simulation or tests	Refer to table 1.4
		Relation diagram of wrap around distance and heat impact test at 45 km/h				Simulation result	
3	Pedestrian protection at lower threshold speed	40 km/h, predicated results of head form test zone when system starting				Simulation result	-----
		At lower threshold speed, predicated results of head form test zone when no system starting				Simulation result	Random testing from C-NCAP Test Assessment Department (not more than 3 times)
4	Stiffness requirement to bonnet	Bonnet deformation while engine starts and not starts.				Simulation result	-----
<p>Note: 1. OEMs should provide the situation statement of the system, vehicle information, working principle and status of active deployable bonnet and bumper testing area statement. 2. The simulation environment and model information should be reflected in the calculation document provided from OEMs. The Output should accord with the experimental procedure.</p>							

3.2. Relation diagram of wrap around distance and heat impact test

Response time of the system at 45 km/h	Sensing time(ms)	Deployment time (ms)	Response time (ms)															
WAD vs HIT	<p>The graph shows a positive linear relationship between Wrap Around Distance (mm) and Head Impact Time (ms). The TRT (Total Response Time) is indicated by a horizontal line at approximately 50 ms. The data points are as follows:</p> <table border="1"> <thead> <tr> <th>Label</th> <th>Wrap Around Distance (mm)</th> <th>Head Impact Time (ms)</th> </tr> </thead> <tbody> <tr> <td>6YD</td> <td>1000</td> <td>60</td> </tr> <tr> <td>5th F</td> <td>1400</td> <td>85</td> </tr> <tr> <td>50th M</td> <td>1700</td> <td>115</td> </tr> <tr> <td>95th M</td> <td>2000</td> <td>135</td> </tr> </tbody> </table>			Label	Wrap Around Distance (mm)	Head Impact Time (ms)	6YD	1000	60	5th F	1400	85	50th M	1700	115	95th M	2000	135
Label	Wrap Around Distance (mm)	Head Impact Time (ms)																
6YD	1000	60																
5th F	1400	85																
50th M	1700	115																
95th M	2000	135																
Evaluation	The area that can meet the requirement $TRT \leq HIT$: <input type="checkbox"/> the whole area; <input type="checkbox"/> WAD: mm ~ mm																	

Appendix 3-3 C-NCAP Basic Parameters of the Test Vehicle 3 -(Part of AEB)

Completed on:(d/m/y)

1. Basic test parameter of AEB test

Parameter	Statement
Vehicle number	
Vehicle type	
VIN number	
Complete vehicle kerb mass and axle load (kg)	
Complete vehicle gross mass and axle load (kg)	
Vehicle L×W×H (mm)	
Axes Count	
Wheel base(mm)	
Wheel track (mm)	
Front and rear suspensions(mm)	
Maximum design speed(km/h)	
Tire type	
Tire pressure(kPa)	
Coordinates of the center of mass(x,y,z)	
Height of the center of mass(full/no-load)(mm)	
Transmission type	
Power assisting type of travel braking system	
Braking adjustment model	
Travel braking model	
Number, tpye and supplier of laser radar	
Number, tpye and supplier of millimeter-wave radar	
Number, tpye and supplier of other radar	
Number, tpye and supplier of camera	
Number, tpye and supplier of infrared sensor	
Number, tpye and supplier of AEB ECU	
Wert of A, B, C(mm)	

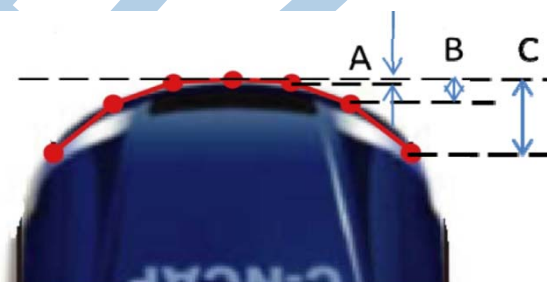

Note: remove 50 mm width from left and right side and divide the car head outlet by 6 points, and measure the distance from middel point to A, B, C, and fill in the table.

2.System information of AEB CCR

- AEB type
 - AEB+FCW AEB FCW
 - millimeter-wave radar laser radar single camera binocular cameras
 - integration of millimeter-wave radar and cameras other
2. Realisation technique of AEB CCR
3. AEB CCR is deactive while vehicle starts Yes No
4. If AEB CCR can be shuttled off by single button and single operation Yes No
5. If AEB CCR includes DBS Yes No

6. Type of warning signal acoustic visual tactile Frequency of the signal: _____ Hz

7. Besides acoustic and visual warning requirements, FCW has other warning forms(Head-up, Seat belt vibration, snub or others)

8. If the system has the function of seat belt pre-tensioner Yes No

9. Working range of AEB:

1. AEB subspeed(the lowest working speed) CCRs:_____ km/h, CCRm:_____ km/h.

2.AEB maximum speed(the highest working speed) CCRs:_____ km/h, CCRm:_____ km/h.

Working range of FCW:

1. AEB subspeed(the lowest working speed) CCRs:_____ km/h, CCRm:_____ km/h.

2.AEB maximum speed(the highest working speed) CCRs:_____ km/h, CCRm:_____ km/h.

10. FCW The braking characteristic curve

D4:_____ mm, F4:_____ N, braking speed:_____ mm/s

3. AEB VRU_Ped system information

1. If FCW is contained: Yes No

millimeter-wave radar laser radar single camera binocular cameras

2. Realisation technique of AEB VRU integration of millimeter-wave radar and cameras other

3. In case of CVNA-75, AEB VRU_Ped can start work at 10 km/h(warning or braking) Yes No

3. In case of CVNA-75, AEB VRU_Ped can reduce the speed of car at 10 km/h of car and 3 km/h of the pedestrian. Yes No

4. If AEB VRU can be shuttled off by single button and single operation Yes No

5. In case of CVFA-75 and 45 km/h, warning time TTC≥1.2 s Yes No

6. Type of warning signal acoustic visual tactile Frequency of the signal: _____ Hz

9. Working range of AEB VRU_Ped:

AEB VRU_Ped subspeed(the lowest working speed) CVNA-25:_____ km/h, CVNA-75:_____ km/h; CVFA-25:_____ km/h, CVFA-50:_____ km/h.

AEB VRU_Ped maximum speed(the highest working speed) CVNA-25:_____ km/h, CVNA-75:_____ km/h; CVFA-25:_____ km/h, CVFA-50:_____ km/h.

4. C-CNCAP AEB CCR test result prediction

Misuse				
		If AEB works	If FCW works	If DBS works after warning of FCW
Braking test of vehicle on adjacent lane				
Iron plate test				
CCRs				
AEB				
Speed km/h	Initial relative velocity	Crashing relative velocity	Speed weight	Score
20			1	
30			1	
40			3	
Total score			5	
Scoring rate	-----			
FCW				
Speed km/h	Initial relative velocity	Crashing relative velocity	Speed weight	Score
35			1	
45			2	

55			2	
75			1	
Total score			6	
Scoring rate	-----			
CCRM				
AEB				
Speed km/h	Initial relative velocity	Crashing relative velocity	Speed weight	Score
30	10		1	
45	25		1	
65	45		3	
Total score			5	
Scoring rate	-----			
FCW				
Speed km/h	Initial relative velocity	Crashing relative velocity	Speed weight	Score
50	30		1	
60	40		3	
75	55		3	
Total score			7	
Scoring rate	-----			
CCRB				
AEB				
Working condition	Initial relative velocity	Crashing relative velocity	Speed weight	Score
12m-4m/s ²	50		1	
40m-4m/s ²	50		1	
total score			2	
Scoring rate	-----			
FCW				
Working condition	Initial relative velocity	Crashing relative velocity	Speed weight	Score
12m-4m/s ²	50		1	
40m-4m/s ²	50		1	
total score			2	
Scoring rate	-----			

5. C-CNCAP AEB VRU_Ped test result prediction

CVFA-25				
Speed km/h	Initial relative velocity	Crashing relative velocity	Speed weight	Score
20	20		1	
30	30		2	
40	40		2	
50	50		2	
60	60		1	
Score			8	
Scoring rate	-----			
CVFA-50				
Speed km/h	Initial relative velocity	Crashing relative velocity	Speed weight	Score
20	20		1	

30	30		2	
40	40		2	
50	50		2	
60	60		1	
Score			8	
Scoring rate	-----			
CVNA-25				
Speed km/h	Initial relative velocity	Crashing relative velocity	Speed weight	Score
20	20		1	
30	30		1	
40	40		2	
50	50		2	
60	60		1	
Score			7	
Scoring rate	-----			
CVNA-75				
Speed km/h	Initial relative velocity	Crashing relative velocity	Speed weight	Score
20	20		1	
30	30		1	
40	40		2	
50	50		2	
60	60		1	
Score			7	
Scoring rate	-----			

Appendix 4 Sheet of Complaint on C-NCAP Assessment

Manufacturer (affix common seal)	(d/m/y)
Vehicle type	
Testing time	
Complained test items	
Complaint grounds	
Retesting time applied	
The authority's opinions (affix common seal)	(d/m/y)

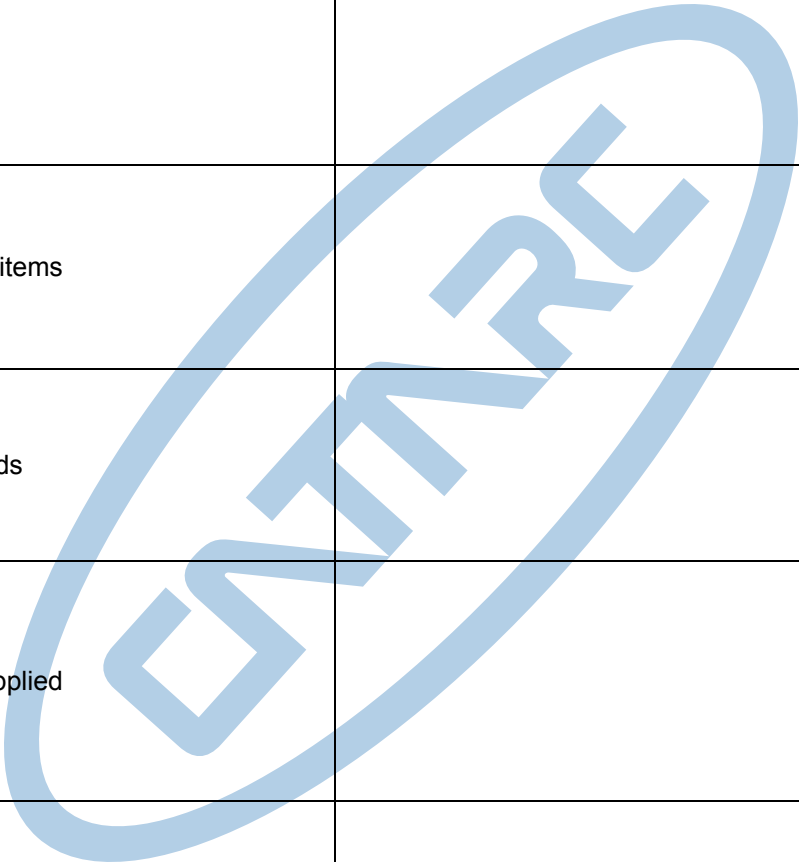

Appendix 5 Application Form Undergoing C-NCAP Assessment

Vehicle manufacturer				
Vehicle type		Total sales volume		
Series put for sales		Configuration for test/Sales volume		
Trademark		The other configuration/ Sales volume		
Time to market				
Vehicle configuration	Overall dimension	L×W×H (mm)		
	Mass	Complete vehicle gross mass (kg)		
		Complete vehicle kerb mass (kg)		
	Bodywork type			
	Engine	Model		
		Manufacturer		
		Displacement		
		Power		
		Number of cylinders		
		Fuel type		
		OBD system		
	Transmission	Automated or manual		
		Number of gears and gear ratios		
	Drive type	Frontal-wheel/rear-wheel/all-wheel drive		
	Restraint system	Safety belt (mounting position, number)		
		Safety belt warning device (position, number)		1. seat row: 2. seat row:
		Airbag (mounting position, number)		
		Seat belt (installation site, quantity)		
if there is seat belt in 2. seat row		<input type="checkbox"/> Yes <input type="checkbox"/> No		
Quantity and positions of Isofix				
Driver's seat	Seat model			
	Manufacturer			
	if active head rest installed			
Others	Active deployable bonnet system			
	ESC system			
	AEB system			
Accessories situation	How long will the pedestrian protection parts be provided?			
Communication	Contact person		Tel.	
	Zip code		Fax.	
	Address			
Statement	In the case of no dispute over the testing for assessment, the evaluation results are to be released on website(s) and magazine(s).			
Common seal	(d/m/y)			

Appendix 6 Specimen of Releasing of C-NCAP Assessment Results

Safety

C-NCAP

The evaluation results of the first batch of models in 2018

Vehicle Picture

Passenger protection ■ Full points ■ 50% to full point ■ One 50% point ■ 0 points

Full frontal impact test

Test score: Dummy color picture

	1 row seat row						Second seat row		penalty point
	Head	Neck	Thorax	Upper leg	Lower leg	Head and Neck	Thorax		
Full points	5	2	5	2	2	2	2	-	
Test score									

Picture of Full frontal impact test moment

Vehicle Name

Changan ford motor co., LTD

Overall star rating

Total score:

Passenger protection score:

Pedestrian protection score:

Active safety test score:

(Electrical safety state:)

Reasons for losing points:

The unlocking force of seat belt of female dummy in the second row is over 60 N.

40% offset impact test

Test score:

	Front seat row				Second seat row		penalty point
	Head and neck	Thorax	Upper leg	Lower leg	Head and Neck	Thorax	
Full points	4	4	4	4	2	2	-
Test score							

Picture of 40% offset impact test moment

Vehicle type:

Vehicle number:

The price of test vehicle(in 10 thousand RMB):

LengthxWidthxHeight(mm):

Volumm of engine(mL):

Curb weight(Kg):

Max. mass(Kg):

Driver and passenger airbag:

Side airbag:

Curtain airbag:

Seat belt pretensioner:

Seat belt restraints:

Driver SBR:

Passenger SBR:

Passenger seat using states monitoring:

Isotix:

FSC:

Voluntary application:

Safety system	Model number	Manufacturing enterprise	Comments
Driver and passenger airbag and knee airbag			
Side airbag and curtain airbag			
Front seat belt			
Second row right side seat belt			
Driver seat			
ECU of ESC			

Side impact test

Test score:

	Front seat row				Second seat row		penalty point
	Head	Thorax	Abdomen	Pelvis	Head	Thorax	
Full points	4	4	4	4	2	2	-
Test score	4	4	4	4	1	1	0

Picture of side impact moment

Whiplash score:

	NIC	Upper neck load	Lower penalty score	Minus point	Full points
Full points	2	2	1	-	5
Test score					

Picture of 100% whiplash test moment

Bonus points:

Picture of pedestrian protection test

Picture of Vehicle color

Pedestrian protection

Pedestrian protection score:

	Head	Leg form	minus point	Full points
Full points	12	3	-	15
Test score				

Active safety

Active safety test score:

	AEB	AEB Pedestrian	ESC	Minus point	Full points
Full points					
Test score					

Picture of active safety test

Appendix 7 C-NCAP Work Flow Diagram

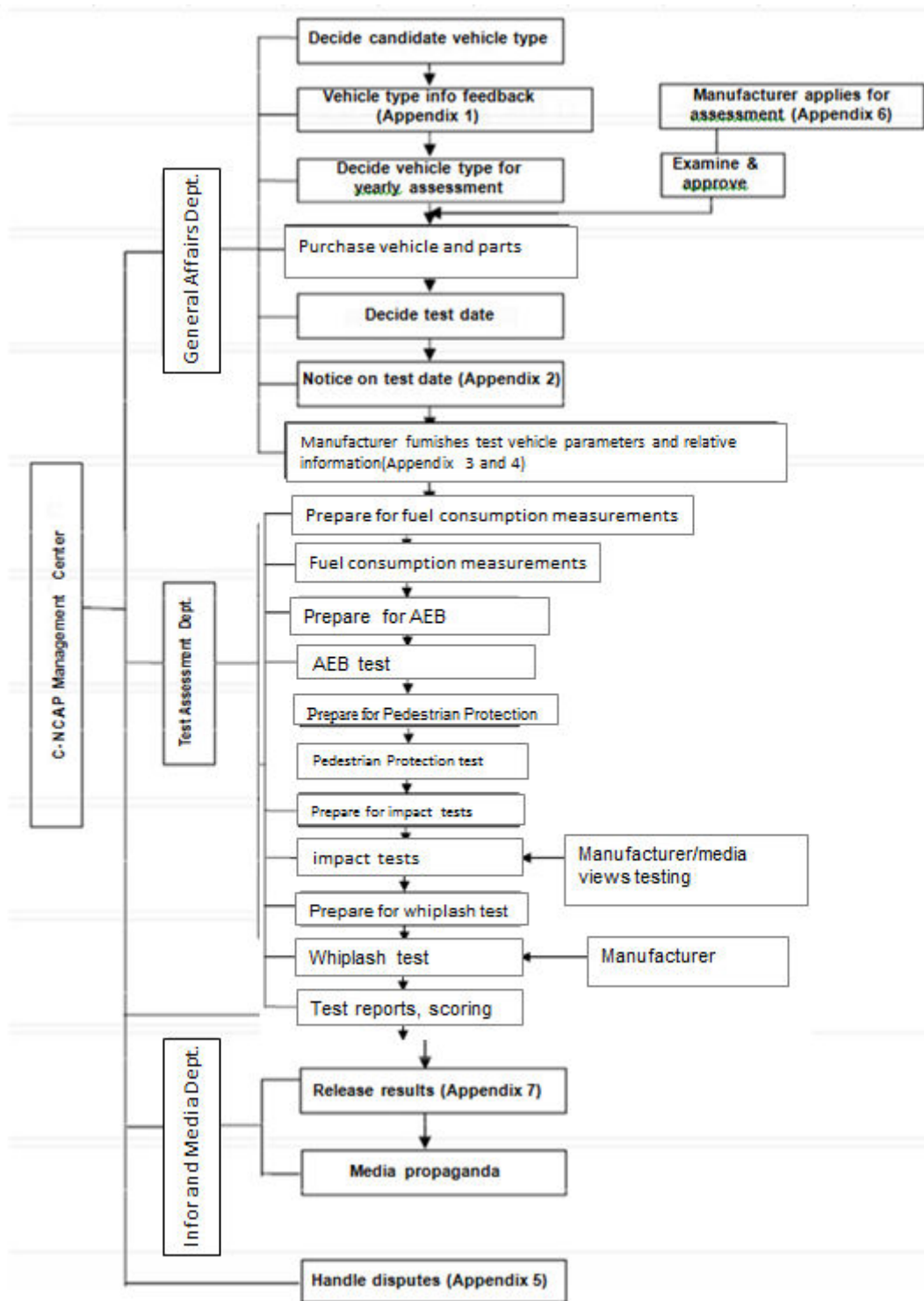

Appendix 8 ESC Parameter Comparison Table

Parameter	Test vehicle for report	C-NCAP vehicle	test
Vehicle model			
Vehicle category			
VIN number			
Chassis model and manufacturer			
Engine model and manufacturer			
Kerb mass and axle load of the whole vehicle (kg)			
Maximum gross mass and axle load of the whole vehicle (kg)			
Axles			
Axle base (mm)			
Wheel track (mm)			
The maximum design speed (km/h)			
Tyre model and manufacturer			
Tyre pressure (kPa) (front/rear)			
Suspension type (front/rear)			
Mass center height (empty load/full load) (mm)			
Engine rated power (kW)			
Engine maximum torque (Nm)			
Engine ECU and manufacturer			
Final drive ratio			
Transmission shift and ratio			
Drive type			
Service braking booster pattern			
Service brake system type			
Brake master cylinder model and manufacturer			
Braking caliper model			
Braking disc model			
Braking shoe model			
Braking drum model			
Braking liner model			
Steering system type			
Steering booster model and manufacturer			
ESC system controller model and manufacturer			
Braking pressure adjuster model and manufacturer			
Steering wheel angle sensor model and manufacturer			
Yaw rate and lateral accelerometer model and manufacturer			
Wheel speed sensor model and manufacturer			

Appendix 9 Information Sheet of Manufacturer's Sample (for Gasoline Vehicle)

Parameters	Vehicle category			Trademark		
	Sample grade			Model & specifications		
	Manufacturer			Manufacture date		
	Chassis	VIN		Engine	Model	
		Model			Serial number	
		Manufacturer			Manufacturer	
	Complete vehicle kerb mass (kg)				Displacement (L)	
	Gross vehicle weight (kg)				Engine type	
	Maximum attainable velocity (km/h)				Cylinder/valve quantity	
	Designed number of occupants				Rated output (kW)/speed (r/min)	
	Drive pattern/transmission type				Layout of combustion chamber	
	Tyre inflation pressure of driving wheel (kPa)				Idling speed (r/min)	
	Tyre size				Volumetric compression ratio	
	Tyre manufacturer				Air intake/cooling mode	
	Tyre structure				Cylinder arrangement pattern	
	Sectional width of tyre				Bore/stroke/cylinder center line spacing	
	Fuel type & grade			Engine fueling mode		
	OBD system available?			Fuel pipe material		
	Final drive ratio			Fuel tank Volume (L)/material		
	Gear ratios	Gear 1		ECU		Model/appearance No.
		Gear 3				Manufacturer
		Gear 5				Manufacturer
	Booster	Model/appearance No.		Intercooler		Model/appearance No.
		Manufacturer				Manufacturer
	Catalyst	Model/appearance No.		Quantity of catalytic units/content of precious metals (g/ft ³)		
		Manufacturer		Ratio of precious metals (Pt: Pd: Rh)		
		Quantity		Carrier structure/material		
		Volume (L)		Pore density (mesh/in ²)		
	OS	Catalyst type		Mounting interval from exhaust opening (mm)		
		Model/appearance No.		PCV		Model/appearance No.
Manufacturer		Manufacturer				
Model/appearance No.		Control mode				
Canister	Manufacturer		Throttle size			
	Model/appearance No.		EGR		Model/appearance No.	
Manufacturer		Manufacturer				
Secondary air injection	Type		Declared fuel consumption (L/100km)			
	Model/appearance No.					
Manufacturer						
Other particular notes						

Information sheet of manufacturer's sample (for diesel vehicle)

Parameters	Vehicle category			Trademark		
	Sample grade			Model & specifications		
	Manufacturer			Manufacture date		
	Chassis	VIN			Engine	Model
		Model				Number
		Manufacturer				Manufacturer
	Complete vehicle kerb mass (kg)			Engine type		
	Gross vehicle weight (kg)			Displacement (L)		
	Maximum attainable velocity (km/h)			Cylinder/valve quantity		
	Fuel type & specifications			Rated output (kW)/speed (r/min)		
	Fuelling pattern			Maximum torque (N.m)/speed (r/min)		
	Designed number of occupants			Air intake/cooling mode		
	Drive pattern/transmission type			Structure of combustion chamber		
	Tyre inflation pressure of driving wheel (kPa)			Injection type		<input type="checkbox"/> Direct <input type="checkbox"/> Other
	Tyre model			Idling speed (r/min)		
	Tyre manufacturer			Maximum unladen speed (r/min)		
	Tyre structure			Volumetric compression ratio		
	Sectional width of tyre			Cylinder arrangement pattern		
	OBD system available?			Bore/stroke/cylinder center line spacing		
	Final drive ratio			Firing order		
	Gear ratios	Gear 1	Gear 2	ECU	Model/appearance No.	
		Gear 3	Gear 4		Manufacturer	
		Gear 5	Gear 6		Model/appearance No.	
	Injector pump	Model/appearance No.			Fuel injector	Model/appearance No.
		Manufacturer				Manufacturer
	Booster	Model/appearance No.			Intercooler	Model/appearance No.
		Manufacturer				Manufacturer
	Speed governor	Model/appearance No.				Maximum temperature at outlet
Manufacturer			Secondary air injection system	Model/appearance No.		
PM trap	Model/appearance No.			Manufacturer		
	Manufacturer			Type (pulse/air pump)		
Catalyst	Type			Quantity of catalytic units/content of precious metals (g/ft3)		
	Model/appearance No.			Ratio of precious metals (Pt: Pd: Rh)		
	Manufacturer			Carrier structure/material		
	Quantity			Pore density (mesh/in ²)		
	Volume (L)			Mounting interval from exhaust opening (mm)		
Catalyst type			Declared fuel consumption (L/100km)			
Other particular notes						

Appendix 10 C-NCAP Recording Sheet of Measurements and Scoring for Impact Tests

1.Occupant protection part

Item		Head		Neck		Thorax		Femur		Lower leg		Overall penalty	Score	
1. Frontal impact test against the rigid barrier with 100% overlapping	Frontal-row dummies	Test data	Driver-side HIC36	Driver-side positive shearing force Fx@0, 25, 45ms (kN)		Driver-side compressive deformation (mm)	Driver-side femur compression force @0, 10ms (kN)	Left leg	Driver-side TI value	Left leg				
				Driver-side negative shearing force Fx@0, 25, 45ms (kN)				Right leg		Right leg				
			Driver-side 3ms (g)	Driver-side positive tension Fz@0, 35, 60ms (kN)		Driver-side 3ms (g)	Driver-side knee displacement (mm)	Left leg	Driver-side tibia compression force (kN)	Left leg				
				Driver-side extension bending moment My(l)(Nm)				Right leg		Right leg				
			Upward displacement of steering column (mm)	Occupant-side positive shearing force Fx@0, 25, 45ms (kN)		Rearward displacement of steering column (mm)	Occupant- side femur compression force @0, 10ms (kN)	Left leg	Occupant- side TI value	Left leg				
				Occupant-side negative shearing force Fx@0, 25, 45ms (kN)				Right leg		Right leg				
			Occupant side HIC36	Occupant-side positive tension Fz@0, 35, 60ms (kN)		Occupant- side compressive deformation(mm)	Occupant- side knee displacement (mm)	Left leg	Occupant- side tibia compression force (kN)	Left leg				
			Occupant side 3ms (g)	Occupant-side extension bending moment My(l)(Nm)		Occupant- side 3ms (g)		Right leg		Right leg				
			Score											
			2. Frontal impact test against the rigid barrier with 100% overlapping	Rear-row female dummy	Test data	No secondary impact of head		With secondary impact of head		Compressive deformation (mm)	Ilium force unloading rate (N/ms)		Left side	
Head	Head HIC15					right side								
Neck Fz	Neck Fz													
-----	Neck Fx													
-----	Neck My													
Score														
2. Frontal impact test against the deformable barrier with 40% overlapping	Frontal-row dummies	Test data	Head, neck		Thorax		Knee, femur		Lower leg					
			Driver-side HIC36		Driver-side Compressive deformation (mm)	Driver-side femur compression force @0, 10ms(kN)	Left leg	Driver-side TI value	Left leg					
			Driver-side 3ms (g)				Right leg		Right leg					
			Upward displacement of steering column (mm)		Driver-side thorax VC value (m/s)	Driver-side knee displacement (mm)	Left leg	Driver-side tibia compression force (kN)	Left leg					
			Driver-side positive shearing force Fx@0, 25, 45ms (kN)				Right leg		Right leg					
			Driver-side negative shearing force Fx@0, 25, 45ms (kN)		Rearward displacement of steering column (mm)	Occupant- side femur compression force @0, 10ms(kN)	Left leg	Maximum pedal rearward displacement (mm)						
			Driver-side positive tension Fz@0, 35, 60ms (kN)				Right leg		Maximum pedal upward displacement (mm)					
			Driver-side extension bending moment My(l)(Nm)		A-pillar rearward displacement (mm)		Left leg							
			Score											

			Occupant-side HIC36	Driver-side Compressive deformation (mm)						Left leg			
			Occupant-side 3ms (g)							Right leg			
			Occupant-side positive shearing force Fx@0, 25, 45ms (kN)							Occupant-side TI value			
			Occupant-side negative shearing force Fx@0, 25, 45ms (kN)							Left leg			
			Occupant-side positive tension Fz@0, 35, 60ms (kN)							Right leg			
			Occupant-side extension bending moment My(l)(Nm)							Occupant-side tibia compression force (kN)			
Score													
test against the deformable barrier with 40%	Rear-row female dummy	Test data	No secondary impact of head		secondary impact of head		Compressive deformation	Ilium force unloading rate(N/ms)	Left side	Right side			
			Head	Head HIC15									
			Neck Fz	Neck Fz									
			Neck Fx	Neck Fx									
Score													
5. Side impact test against mobile deformable barrier	Front-row dummies	Measurement value	Head		Thorax		Abdomen		Pelvis				
			Head HIC15		Compressive deformation(mm)		Compressive deformation(mm)		Pubis force (kN)				
			3ms (g)		VC value (m/s)		VC value (m/s)		-----				
	Score												
	Rear-row female dummy	Measurement value	Head HIC15	Compressive deformation(mm)		Compressive deformation(mm)		Resultant pelvis force (hip joint and iliac bone)					
			Score										
4. Whiplash test	Item	Neck injury criterion (NIC)			Upper neck loads and torques			Upper neck loads and torques			Penalty item		Whiplash test score
		Measurement value	NIC	Upper shearing force of neck Fx (N)			Lower shearing force of neck Fx (N)			Backrest flare angle (°)			
				Upper tension of neck Fz (N)			Lower tension of neck Fz (N)			Head interference space of head restraint			
				Upper torque of neck My (Nm)			Lower torque of neck My (N)			Track failure (mm)			
Score													
5. Bonus items	Front occupant-side safety belt reminder												
	2. row occupant-side safety belt reminder curtain air bag												
Total score													

2. Pedestrian protection part

2.1.Statistical table predicated results of head form test zone(Grid point method)

Predicated results				Validation test result			
No.	Predicated color	Number of grid points	Predicated points score	Test point	Predicated color/points score	HIC value	Awarded score
1	Default green			C ,			
2	green						
3	yellow						
4	orange						
5	brown						
6	red						
7	Default red		0				
8	blue		-----				
Sum				-----		-----	
Validation test result				Test results in blue area			
Test point	Predicated color/points score	HIC value	Awarded score	Test point	HIC value	Awarded score	
C ,							
Sum		-----		-----	-----		
Correction factor							
Total score of head form test zone points							
Final score of head form test zone							

2.2.Statistical table predicated results of head form test zone(Equivalent area division method)

Area	A		B		C		D		Awarded score	
	HIC Value	Comments	HIC Value	Comments	HIC Value	Comments	HIC Value	Comments		
A1										
A2										
A3										
A4										
A5										
A6										
C1										
C2										
C3										
C4										
C5										
C6										
Total score of head form test zone points										
Final score of head form test zone										
<p>Note: 1. Comments should be filled with the information of this area; M: the area in which are the added test points; N: the area without test points which is evaluated by standard test points; X: the area without test points which is evaluated by added test points; S: the area which are evaluated by its symmetrical area. 2. HIC Value in default green area is 0, in default red area is 9999.</p>										

2.3. Statistical test result of leg form test zone(lower leg)

	Leg torque					Ligament elongation					Grid point score	Comments
	T1	T2	T3	T4	Awarded score	ACL	PCL	Conformity assessment	MCL	Awarded score		
L-7												
L-6												
L-5												
L-4												
L-3												
L-2												
L-1												
L0												
L1												
L2												
L3												
L4												
L5												
L6												
L7												
Total score of leg form test zone points												
Final score of leg form test zone												
Note: Comments should be filled with the information of grid point, T: standard test grid point; M: added test grid point; N: not tested grid point.												

2.4. Statistical test result of leg form test zone(Upper leg)

	Leg torque						Leg impact force				Grid point score	Comments
	Mtop	Awarded score	Mmid	Awarded score	Mbottom	Awarded score	Ftop	Fbottom	Fsum	Awarded score		
U-7												
U-6												
U-5												
U-4												
U-3												
U-2												
U-1												
U0												
U1												
U2												
U3												
U4												
U5												
U6												
U7												
Total score of leg form test zone points												
Final score of leg form test zone												
Note: Comments should be filled with the information of grid point, T: standard test grid point; M: added test grid point; N: not tested grid point.												

2.5. Pedestrian protection score

Final score of head form test zone	
Final score of leg form test zone	
Final score of pedestrian protection	
Score rate of pedestrian protection	
Star level	



3. Active safety part

Basic parameters of the vehicle

Vehicle number			Vehicle name		Test date	
Vehicle manufacturer			VIN		Test standort	
Mass(kg)		Load(Kg)	Front:	Overall dimension(mm)	Wheel base(mm)	
			Rear:			

3.1. AEB CCR

	Item	Weight	Comprehensive serves	Score	Total score rate	No.	Items	Weight	Score	Item (Missuse)	If missuse	Weight	Score
	C-NCAP AEB score(1 point)	AEB	3					HMI Evaluation	De-activation requirement	2		Iron plate test 40 km/h test	
FCW		2			FCW assistance alarm requirement	1				Iron plate test 72 km/h test			
HMI		1				Active safety belt prewarning function			1		Braking test of vehicle on adjacent lane		3
Score rate						100%							

CCRs					CCRm					CCRs						
AEB					AEB					AEB						
Run No	Speed /kph	VUT impact speed	Weight	Score of each point	Run No	Speed /kph	VUT initial relative speed	VUT impact relative speed	Weight	Score of each point	Run No	Work Condition	VUT speed km/h	VUT impact speed	Weight	Score of each point
	20		1			30	10		1			12-4 m/s ²	50		1	
	30		1			45	25		1			40-4 m/s ²	50		1	
	40		3			65	45		3						2	
	Total Score					Total Score						Total Score				
Score rate					Score rate					Score rate						
FCW					FCW					FCW						
Run No	Speed /kph	VUT impact speed	Weight	Score of each point	Run No	Speed /kph	VUT initial relative speed	VUT impact relative speed	Weight	Score of each point	Run No	Work Condition	VUT speed km/h	VUT impact speed	Weight	Score of each point
	35		1			50	30		1			12-4 m/s ²	50		1	
	45		2			60	40		1			40-4 m/s ²	50		1	
	55		2			75	55		3							
	75		1			Total Score						Total Score				
	Total Score					Score rate						Score rate				

3.2. AEB VRU_Pe

1	Items	Weight	HMI point	AEB_Ped score rate				
				Items	Score	Comprehensive serves	Total Score	Total score rate
	De-activation requirement	2						
2	FCW assistance alarm requirement	1		AEB	5			
				HMI	1			

Speed km/h	CVFA-50			CVFA-25			CVNA-25			CVNA-75		
	Impact speed	Weight	Score	Impact speed	Weight	Score	Impact speed	Weight	Score	Impact speed	Weight	Score
20		1			1			1			1	
30		2			2			2			2	
40		2			2			2			2	
50		2			2			2			2	
60		1			1			1			1	
Sum												

3.3. Plate score

ESC	Value	4	AEB-CCR	Value	8	AEB-CCR	Value	
	Equipped in C-NCAP test vehicle and pass the adult			Score rate			Score rate	
	Assembly coefficient			Equipped in C-NCAP test vehicle			Equipped in C-NCAP test vehicle	
				Practical equipment rate			Practical equipment rate	
				Assembly coefficient			Assembly coefficient	
	Final score		Plate score rate					

